

Geophysical Survey Report

covering

Borehole Pulse EM Surveys

over the

Shakespeare Project

for

Ursa Major Minerals Inc.

during

June 2011

by

CRONE GEOPHYSICS & EXPLORATION LTD.

Survey Area:	Shakespeare East Property, Webbwood, Ontario
Survey Type:	Borehole Pulse EM Surveys
Survey Operators:	Andy Sewap
Borehole Surveys:	U-08-02, U-03-113, U-03-114, U-03-116, U-03-118, U-03-120, U-03-121
Survey Period:	June 2011
Report By:	A.M.Khan
Report Date:	June 2011

TABLE OF CONTENTS

PULSE ELECTROMAGNETIC SURVEY

- 1.0** INTRODUCTION
- 2.0** PROPERTY LOCATION
- 3.0** PERSONNEL
- 4.0** SURVEY METHODS
- 5.0** SURVEY PARAMETERS
- 6.0** PRODUCTION SUMMARY

APPENDICES

- APPENDIX I: PLAN AND SECTION MAPS
- APPENDIX II: LINEAR (5-AXIS) PULSE EM DATA PROFILES
- APPENDIX III: PULSE EM DATA PROFILES (LIN-LOG SCALE)
- APPENDIX IV: STEP RESPONSE DATA PROFILES
- APPENDIX V: CRONE INSTRUMENT SPECIFICATIONS

LIST OF FIGURES

- FIGURE 1: SHAKESPEARE PROJECT GENERAL LOCATION
GOOGLE MAP
- FIGURE 2: PROPERTY LOCATION AND ACCESS MAP
- FIGURE 3: LOOP1, HOLE U-08-02, U-03-113, U-03-114,
U-03-116, U-03-118 AND U-03-120 LOCATION
MAP
- FIGURE 4: LOOP2, HOLE U-03-121 LOCATION MAP

LIST OF TABLES

- TABLE I: TRANSMITTER LOOP COVERAGE
- TABLE II: BOREHOLE SURVEY COVERAGE
- TABLE III: CHANNEL CONFIGURATION TIME BASE 50.00 MS
- TABLE IV: CHANNEL CONFIGURATION TIME BASE 16.66 MS
- TABLE V: PRODUCTION SUMMARY

1.0 INTRODUCTION

Crone Geophysics & Exploration Limited was contracted by Ursa Major Minerals Inc. to conduct Borehole Pulse Electromagnetic Surveys on its Shakespeare East Property located in Shakespeare Township, near the village of Webbwood, Ontario. This report summarizes the geophysical work carried out in June 2011.

Seven (7) holes covering two (2) surface loops were surveyed during the survey period June 1st to 23rd, 2011. The appendices to this report contain page size plan maps, PEM profiles (linear 5-axis and logarithmic scale), step response profiles, and instrument specifications.

2.0 PROPERTY LOCATION AND ACCESS

The Shakespeare property is located, immediately north and east of Agnew Lake, near the village of Webbwood, Ontario. The property is approximately 70 km west-southwest of Sudbury, Ontario, about one hour by road from Sudbury. The closest towns are Webbwood, which is 9 km southwest of the property, and Espanola, which is 11 km southeast.

Access into the Shakespeare Property will be from northeast via a secondary road branching north from the Trans Canada Highway # 17 approximately 7.5 km east of Nairn Center. An existing logging road connects to the west side of the secondary road, approximately 13 km from Highway 17 and allows access to the property (Figure-2). For much of its length, this existing logging road is considered to be suitable for site access.

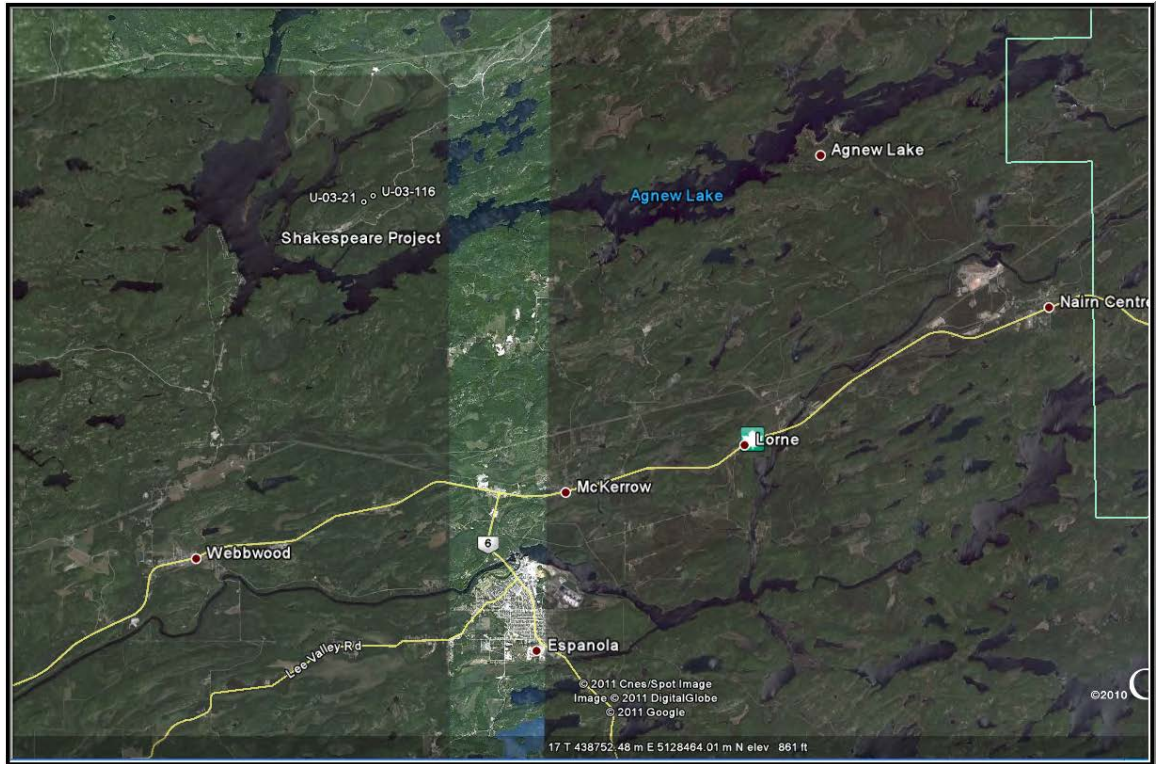

Figure 1: Shakespeare Project General Location Google Map

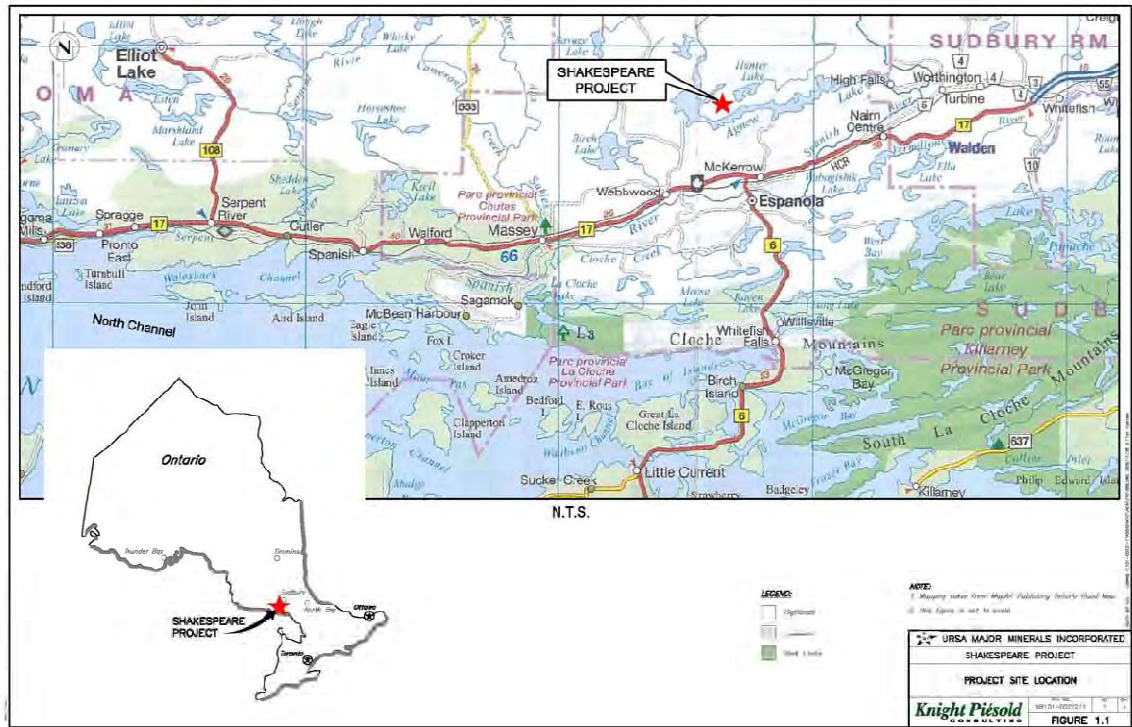

Figure 2: Property Location and Access Map

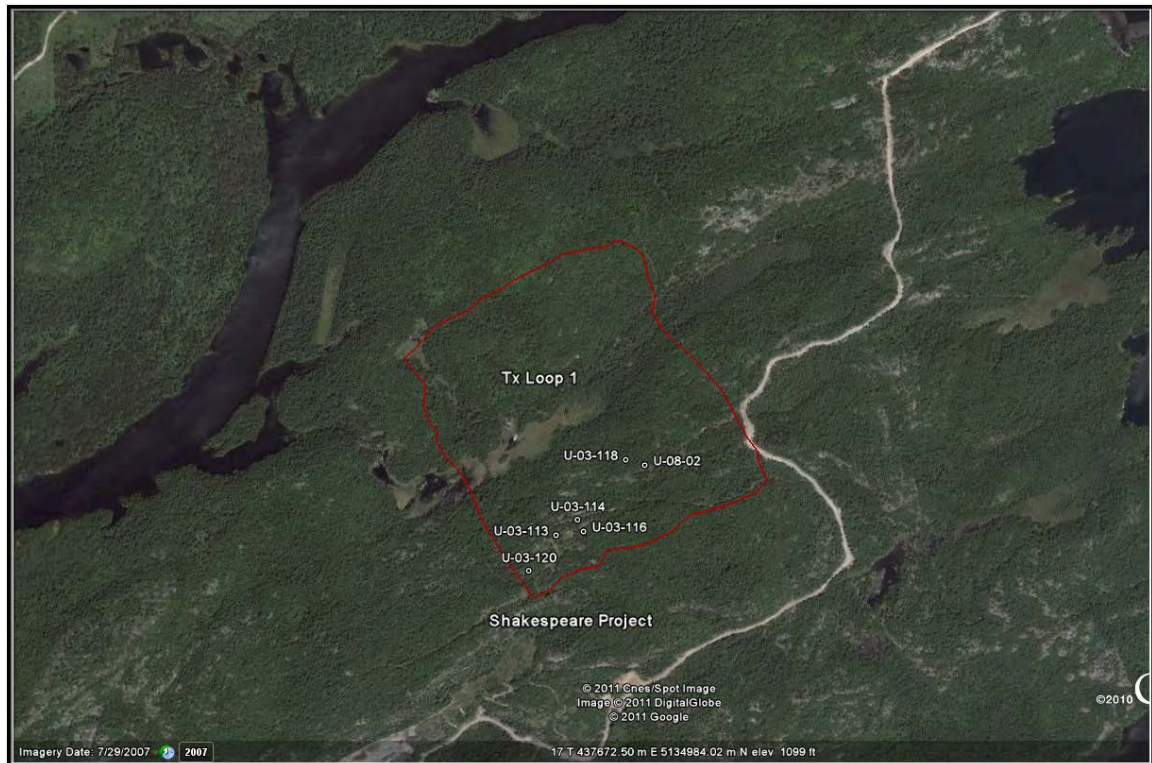

Figure 3: Loop1, Hole U-08-02, U-03-113, U-03-114, U-03-116, U-03-118, U-03-120 Location Map



Figure 4: Loop2, Hole U-03-121 Location Map

3.0 PERSONNEL

The personnel involved in this project during the reporting period include:

Survey Operators: Andy Sewap

Data Processing: Kevin Ralph

Report: A.M.Khan

4.0 SURVEY METHODS

Crone Pulse EM is a time domain electromagnetic method in which a precise pulse of current with a controlled linear shut off is transmitted through a large loop of wire on the ground and the rate of decay of the induced secondary field is measured across a series of time windows during the off-time. The EMF created by the shutting-off of the current induces eddy currents in nearby conductive material thus setting-up a secondary magnetic field. When the primary field is terminated, this magnetic field will decay with time. The amplitude of the secondary field and the decay rate are dependent on the quality and size of the conductor.

On this project, a 3D Borehole Pulse EM system was assembled in which an axial component (Z) probe and a cross component (XY) probe were used to measure the three components of the induced secondary field. The first pass with the 'Z' probe detects any in-hole or off-hole anomalies and gives information on size, conductivity, and distances to the edge of conductors. The second pass with the 'XY' probe measures two orthogonal components of the EM field in a plane orientated at right angles to the borehole. These results give directional information to the center of the conductive body. Data is usually collected at a nominal sample interval of 10m.

In addition to measuring the standard Primary Pulse channel on the ramp and off-time channels, the Step Response may also be calculated. Step Response requires accurate geometrical control in which the loop position and the hole geometry are accurately determined. In the current surveys positional information was collected by Crone using a sub-meter capable GPS and regional base station. Positional information is provided in the UTM projection (zone 17 North), utilizing the NAD 1983 Canada datum. Elevations are given relative to Mean Sea Level based on the EGM96 Global geoids model.

The calculated Step Response values are binned into an S1 channel (from 0.5T to T), an S2 channel (from 0.25T to 0.5T), an S3 channel (from 0.125T to 0.25T) and an S4 channel (from 0.0625T to 0.125T, where T is the time base). The S1 channel is normalized to the theoretical primary field, while S2, S3 and S4 are normalized to S1. The S1 value is used to identify responses from highly conductive sources. In the absence of any conductors the Primary Field should exactly equal the theoretical field for a given component. In the case of generally resistive host and poorer conductors the S1 value will be very close or equal to the theoretical field for a given component

The equipment used on this project was a Crone Pulse EM Borehole system. This includes a 4.8 kW transmitter with a 220V voltage regulator which is powered by

an 11 hp motor generator. The Crone Digital Receiver was used to collect the field data. The synchronization between the Transmitter and the Receiver was maintained by either a crystal-clock or direct cable link

Data units are nT/s.

5.0 SURVEY PARAMETERS

Table I: Transmitter Loop Coverage

Loop	Property	Size (meters)	Corner Coordinates UTM NAD83 Canada Zone 17N
Tx Loop 1	Shakespeare East Property	~1000x1000	436248E, 5134807N 436705E, 5133928N 437530E, 5134371N 437004E, 5135231N
Tx Loop 2	Shakespeare East Property	~1100x1000	436020E, 5134707N 436427E, 5133859N 437522E, 5134370N 437008E, 5135241N

Table II: Borehole Survey Coverage

Hole	TX loop Shakespeare East	Timebase (ms)	Ram p (ms)	Current (Amps)	Station		Comp
					From	To	
U-08-02	Tx Loop 1	16.66	1.5	13.0	30	710	XYZ
U-03-113	Tx Loop 1	50.00	1.5	11.0	20	340	XYZ
U-03-114	Tx Loop 1	50.00	1.5	10.5	20	350	XYZ
U-03-116	Tx Loop 1	50.00	1.5	12.0	20	620	XYZ
U-03-118	Tx Loop 1	16.66	1.5	13.0	20	615	XYZ
U-03-120	Tx Loop 1	50.00	1.5	11.0	20	470	XYZ
U-03-121	Tx Loop 2	50.00	1.5	9.5	20	490	XYZ

The following table shows the various time gates that constitute the channel configurations set up in the Crone PEM Receiver used in the surveys for the hole U-03-113, U-03-114, U-03-116, U-03-120 and U-03-121. The 50.00 ms (5Hz) timebase uses off-time channels 1 – 24.

Table III: Borehole Channel Configuration 50.00 ms

Channel	Start	Finish	Channel	Start	Finish
PP	-200 μ s	-100 μ s			
1	48 μ s	64 μ s	2	64 μ s	84 μ s
3	84 μ s	112 μ s	4	112 μ s	152 μ s
5	152 μ s	204 μ s	6	204 μ s	268 μ s
7	268 μ s	360 μ s	8	360 μ s	480 μ s
9	480 μ s	640 μ s	10	640 μ s	848 μ s
11	848 μ s	1.128 ms	12	1.128 ms	1.496 ms
13	1.496 ms	1.992 ms	14	1.992 ms	2.644 ms
15	2.644 ms	3.512 ms	16	3.512 ms	4.664 ms
17	4.664 ms	6.192 ms	18	6.192 ms	8.22 ms
19	8.22 ms	10.92 ms	20	10.92 ms	14.4 ms
21	14.4 ms	17.7 ms	22	17.7 ms	27.7 ms
23	27.7 ms	37.7 ms	24	37.7 ms	47.7 ms

The following table shows the various time gates that constitute the channel configurations set up in the Crone PEM Receiver used in the surveys for the hole U-08-02 and hole U-03-118. The 16.66 ms timebase uses off-time channels 1 – 20

Table IV: Channel Configuration 16.66 ms

Channel	Start	Finish	Channel	Start	Finish
PP	-200 μ s	-100 μ s			
1	48 μ s	64 μ s	2	64 μ s	84 μ s
3	84 μ s	112 μ s	4	112 μ s	152 μ s
5	152 μ s	204 μ s	6	204 μ s	268 μ s
7	268 μ s	360 μ s	8	360 μ s	480 μ s
9	480 μ s	640 μ s	10	640 μ s	848 μ s
11	848 μ s	1.128 ms	12	1.128 ms	1.496 ms
13	1.496 ms	1.992 ms	14	1.992 ms	2.644 ms
15	2.644 ms	3.512 ms	16	3.512 ms	4.664 ms
17	4.664 ms	6.192 ms	18	6.192 ms	8.22 ms
19	8.22 ms	10.92 ms	20	10.92 ms	14.4 ms

6.0 PRODUCTION SUMMARY

Table V: Production Summary

01-June-2011	MOB
02-June-2011	MOB
03-June-2011	MOB
04-June-2011	Located drill holes and Loop wire.
05-June-2011	Walked to the loop to look for open splices, repaired 6. Surveyed hole U-08-02, Z component.
06-June-2011	Surveyed hole U-08-02, XY components.
07-June-2011	Headed out to grid and took gps coordinates of drill collars.
08-June-2011	Bridge replacement.
09-June-2011	Resurveyed hole U-08-02 XY components.
10-June-2011	Surveyed hole U-03-118, XYZ components.
11-June-2011	Started surveying hole U-03-116 got to 330m on the Z-component when the keypad froze up, perhaps because of moisture. It started to rain.

12-June-2011	Tried RX this am, keypad is still froze, tried doing different things to get it going but did not work.
14-June-2011	Surveyed hole U-03-116, XYZ components.
15-June-2011	Surveying hole U-03-120, Z-component.
16-June-2011	Started surveyed on hole U-03-120, XY components.
17-June-2011	Surveyed hole U-03-120, XY components.
18-June-2011	Surveyed hole U-03-113, XYZ components.
19-June-2011	Surveyed hole U-03-114, XYZ components.
20-June-2011	Hole 03-122 was blocked at 37m so I talked to Client about it. Decided to survey hole 03-121. Started the surveying after 1:00pm and finished off the z-component. Laid Loop2.
21-June-2011	Surveyed hole U-03-121, XY components.
22-June-2011	Picked up 1.1kmx1km loop and packed out the gear, loaded quads.
23-June-2011	DEMOB

Respectfully submitted,

A.M.Khan
Crone Geophysics & Exploration Ltd.



APPENDIX I
PLAN AND SECTION MAPS



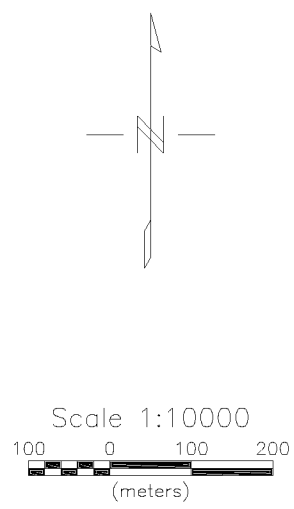
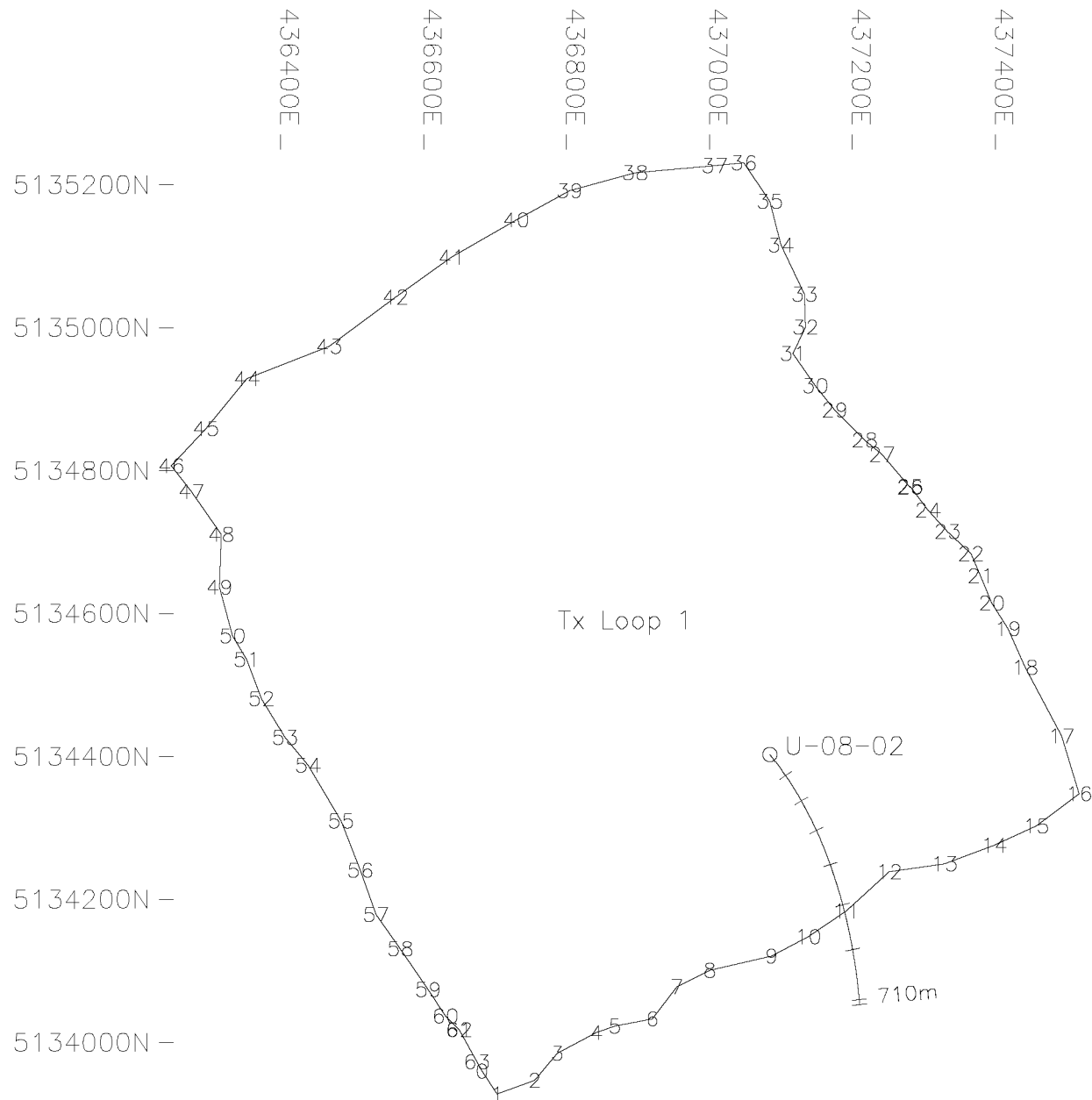

<p><i>Ursa Major Minerals Inc.</i> Shakespeare East Property</p>
<p>3-D Borehole Pulse EM Survey Borehole & Loop Location Map</p>
<p>Hole: U-08-02 Survey Date: June 09, 2011</p>
<p><i>Crone Geophysics & Exploration Ltd.</i></p>

437070E, 5134512N

U-08-02

437262E, 5133943N

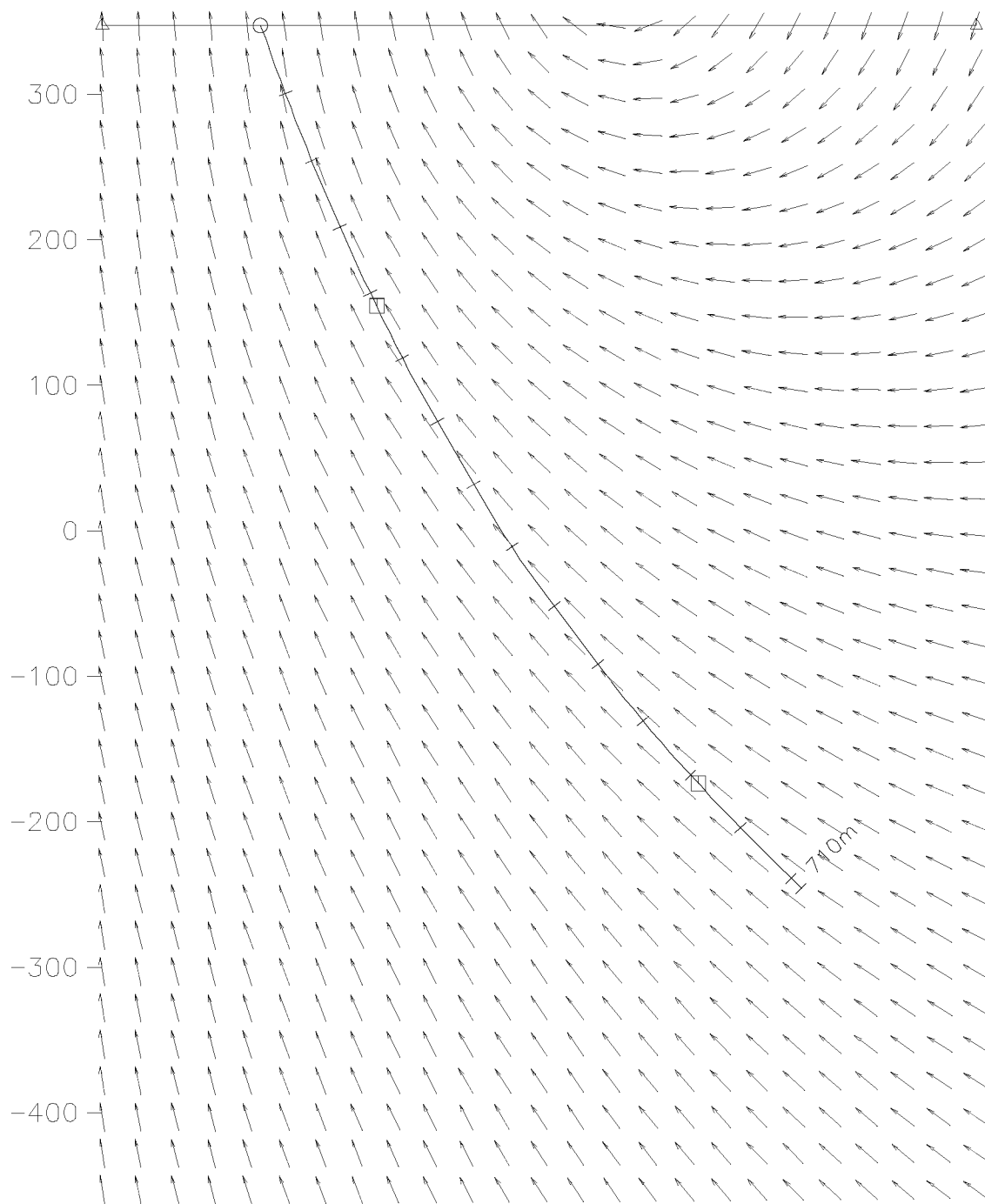

Ursa Major Minerals Inc.
Shakespeare East Property

3-D Borehole Pulse EM Survey
Hole Section with Primary Field

Hole: U-08-02

Survey Date: June 09, 2011

Crone Geophysics & Exploration Ltd.

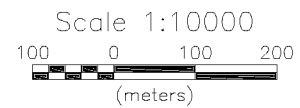
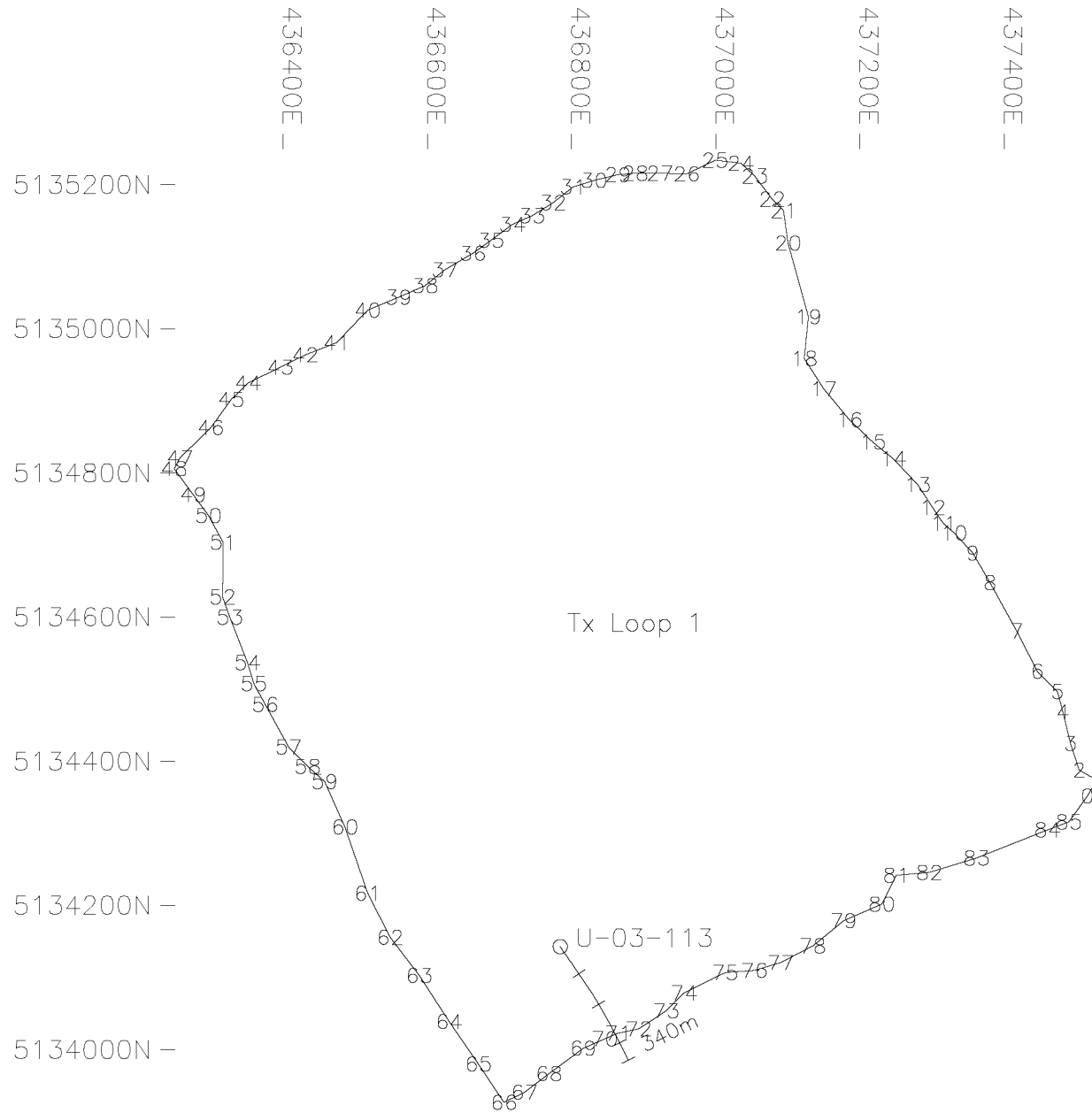

Ursa Major Minerals Inc.
Shakespeare East Property

3-D Borehole Pulse EM Survey
Borehole & Loop Location Map

Hole: U-03-113
Survey Date: June 18, 2011

Crone Geophysics & Exploration Ltd.

436749E, 5134201N

436910E, 5133941N

U-03-113

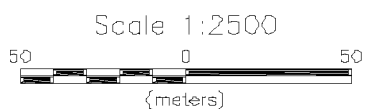
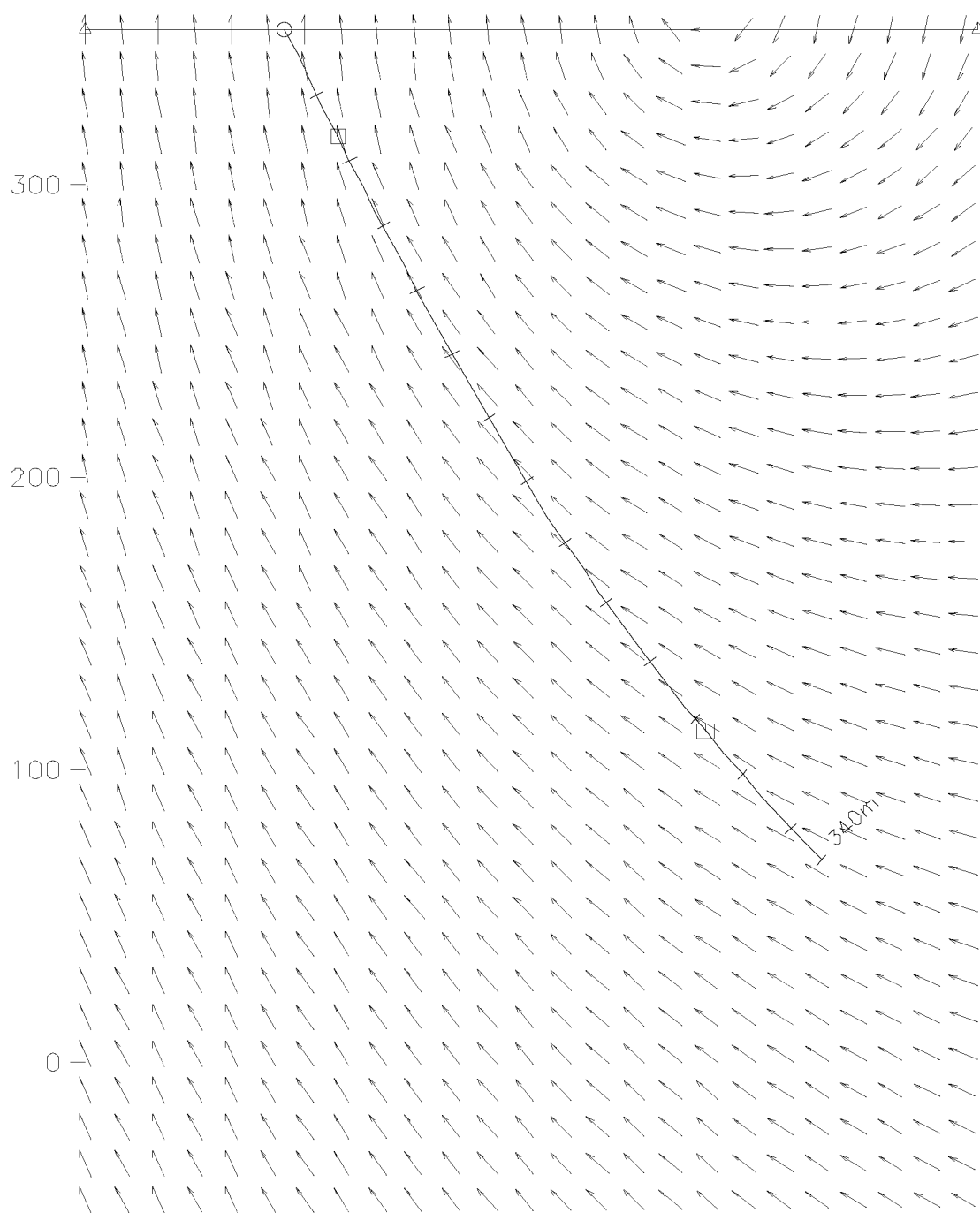

Ursa Major Minerals Inc.
Shakespeare East Property

3-D Borehole Pulse EM Survey
Hole Section with Primary Field

Hole: U-03-113

Survey Date: June 18, 2011

Crone Geophysics & Exploration Ltd.

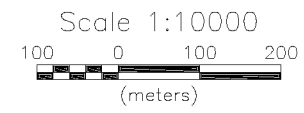
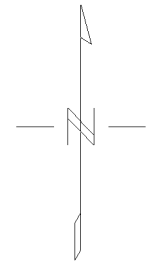
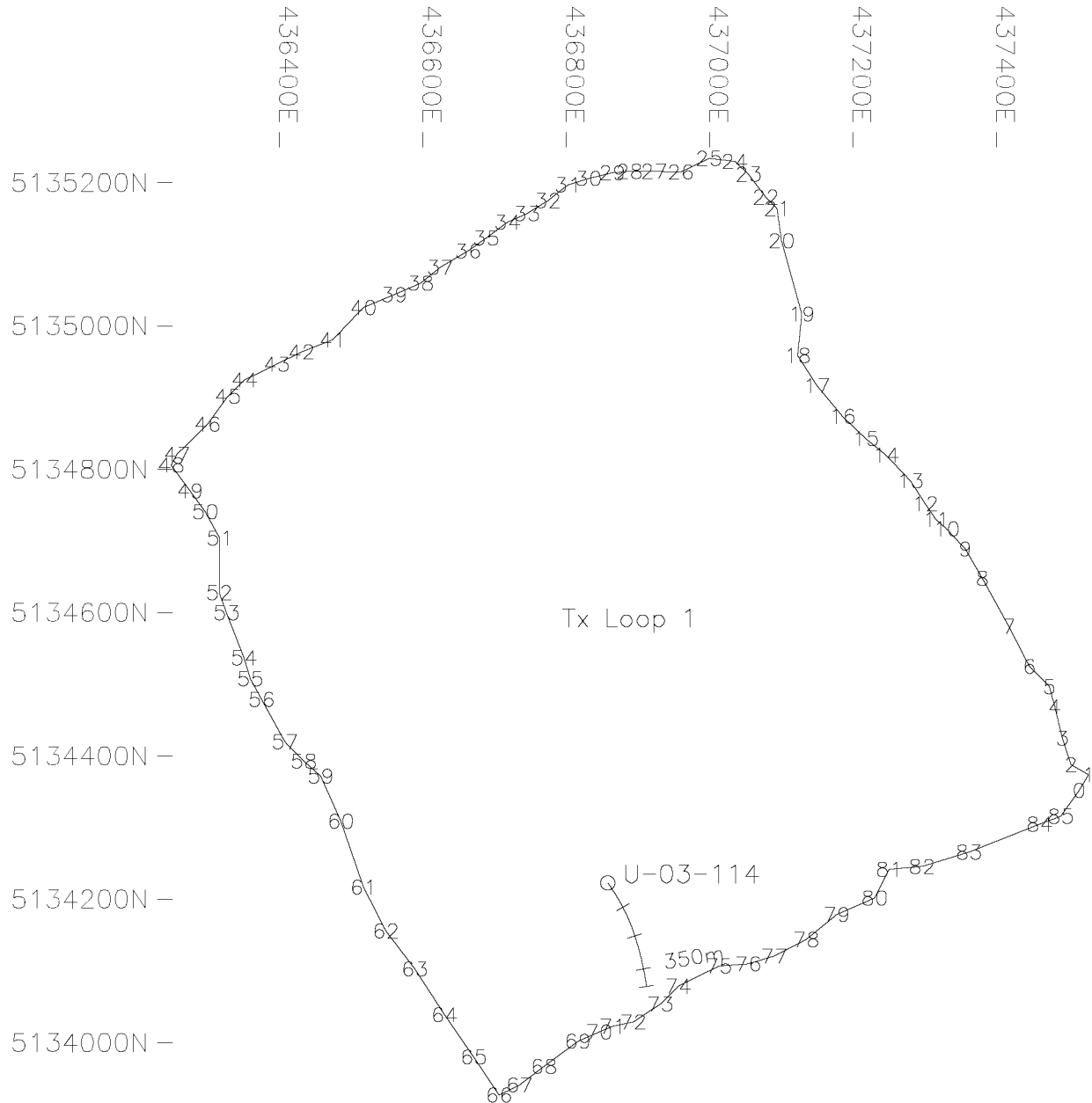

<p><i>Ursa Major Minerals Inc.</i> Shakespeare East Property</p>
<p>3-D Borehole Pulse EM Survey Borehole & Loop Location Map</p>
<p>Hole: U-03-114 Survey Date: June 19, 2011</p>
<p><i>Crone Geophysics & Exploration Ltd.</i></p>

436842E, 5134303N

U-03-114

436935E, 5134016N

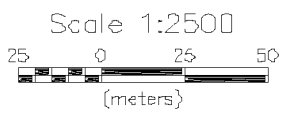
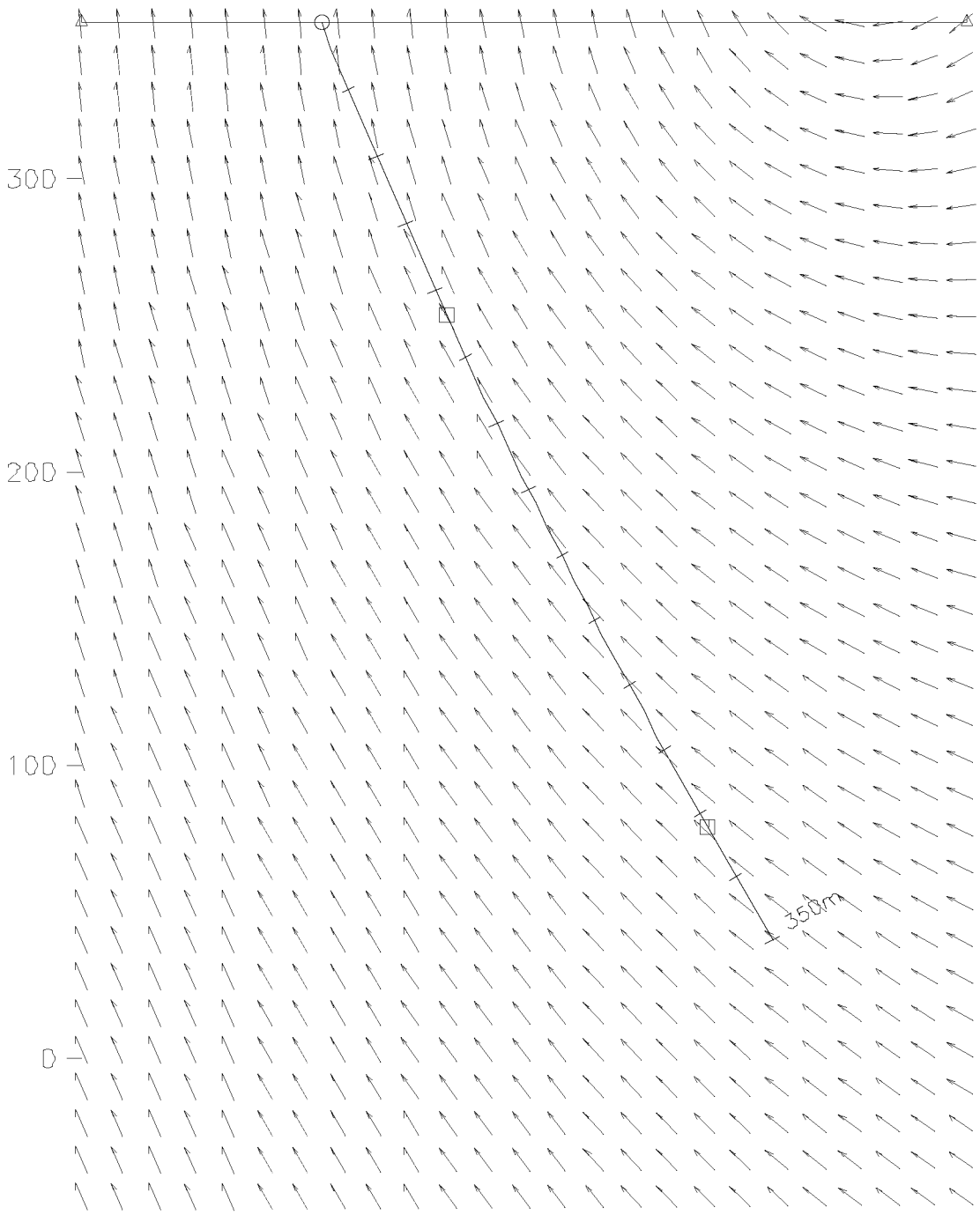

<i>Ursa Major Minerals Inc.</i> Shakespeare East Property
3-D Borehole Pulse EM Survey Hole Section with Primary Field
Hole: U-03-114 Survey Date: June 19, 2011
<i>Crane Geophysics & Exploration Ltd.</i>

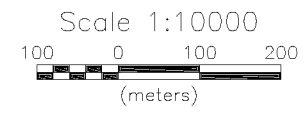
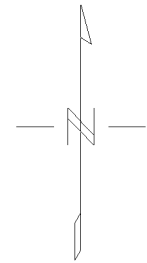
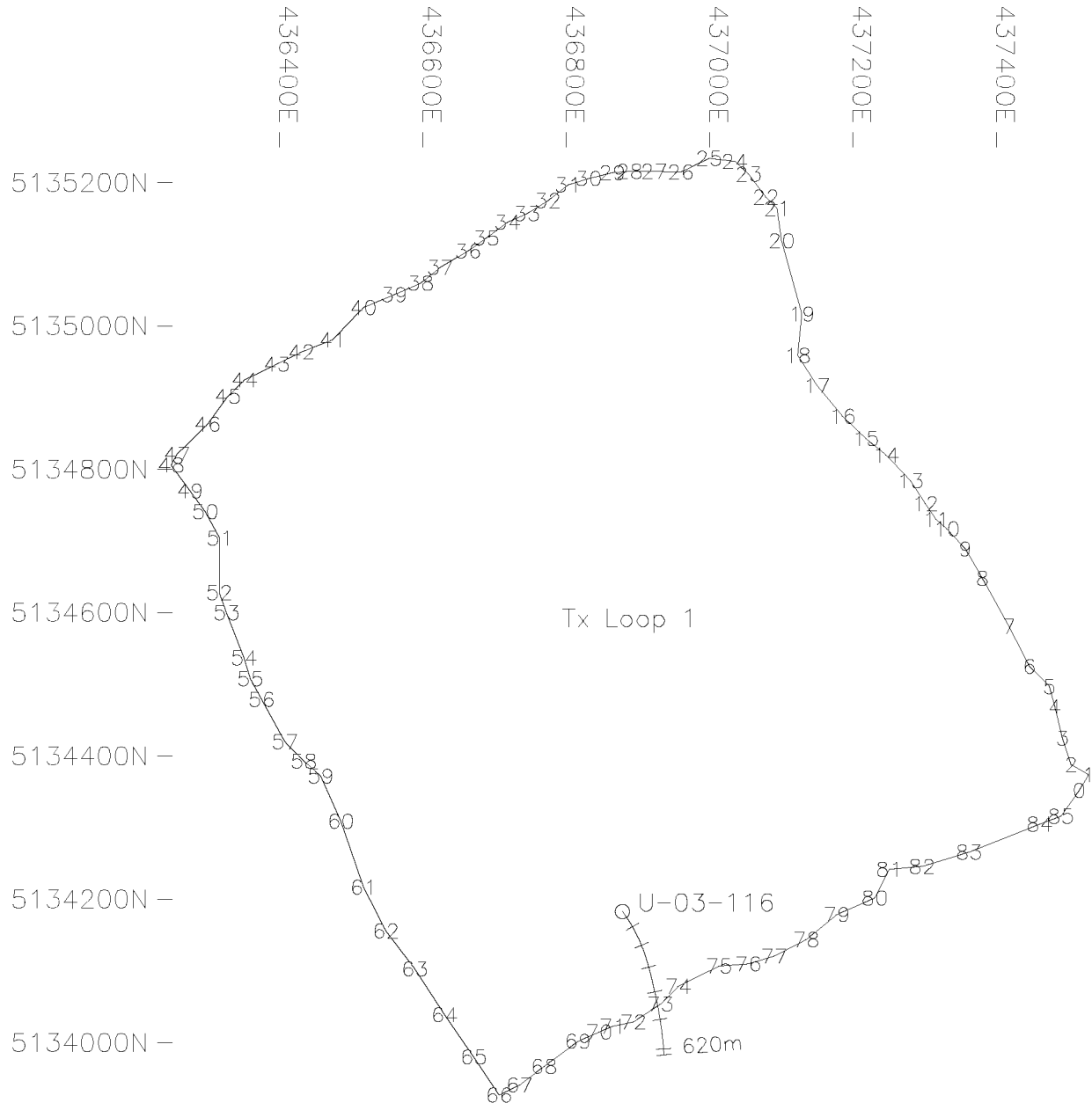

<p><i>Ursa Major Minerals Inc.</i> Shakespeare East Property</p>
<p>3-D Borehole Pulse EM Survey Borehole & Loop Location Map</p>
<p>Hole: U-03-116 Survey Date: June 14, 2011</p>
<p><i>Crone Geophysics & Exploration Ltd.</i></p>

436843E, 5134402N

U-03-116

436971E, 5133810N

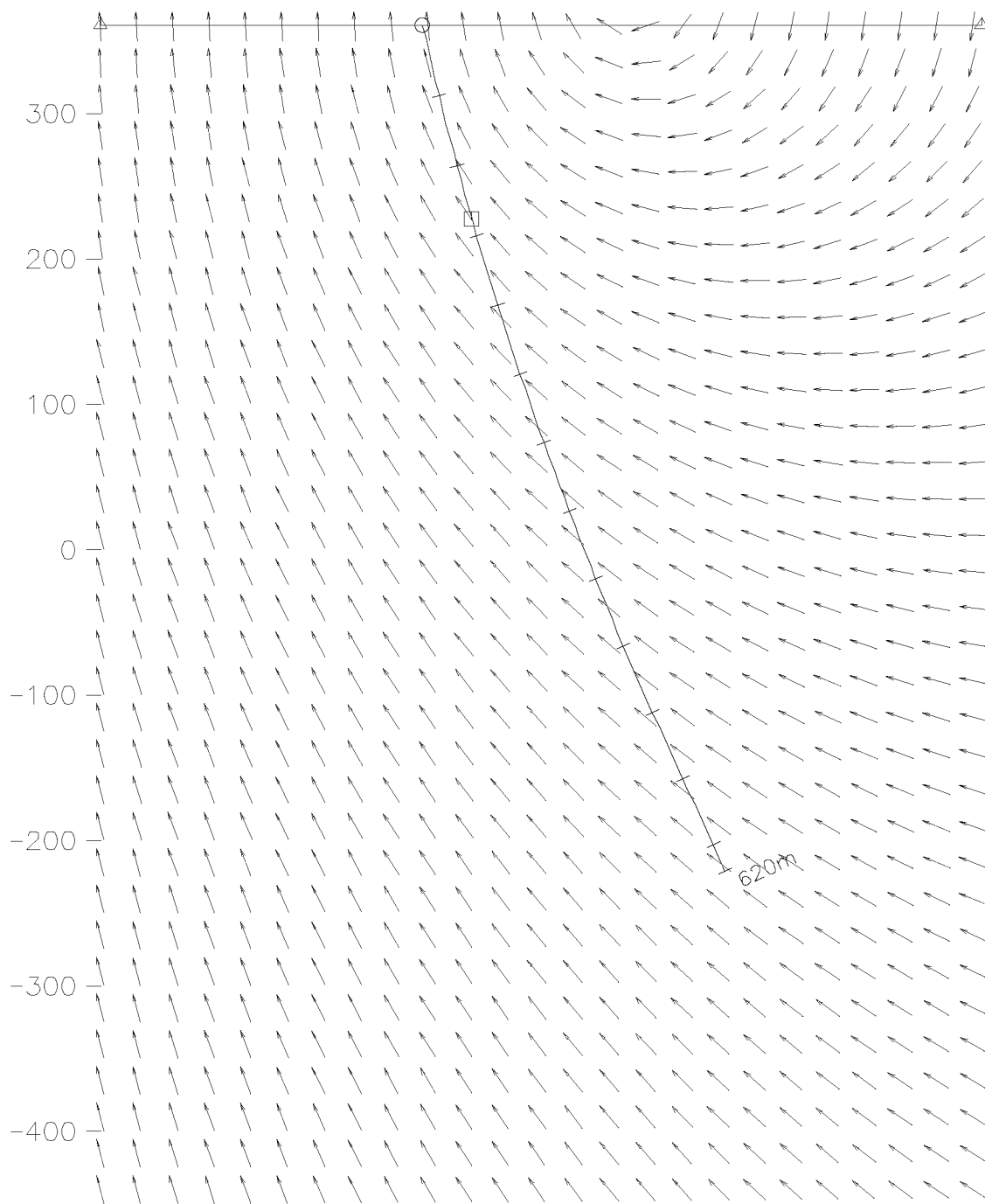

Ursa Major Minerals Inc.
Shakespeare East Property

3-D Borehole Pulse EM Survey
Hole Section with Primary Field

Hole: U-03-116

Survey Date: June 14, 2011

Crone Geophysics & Exploration Ltd.

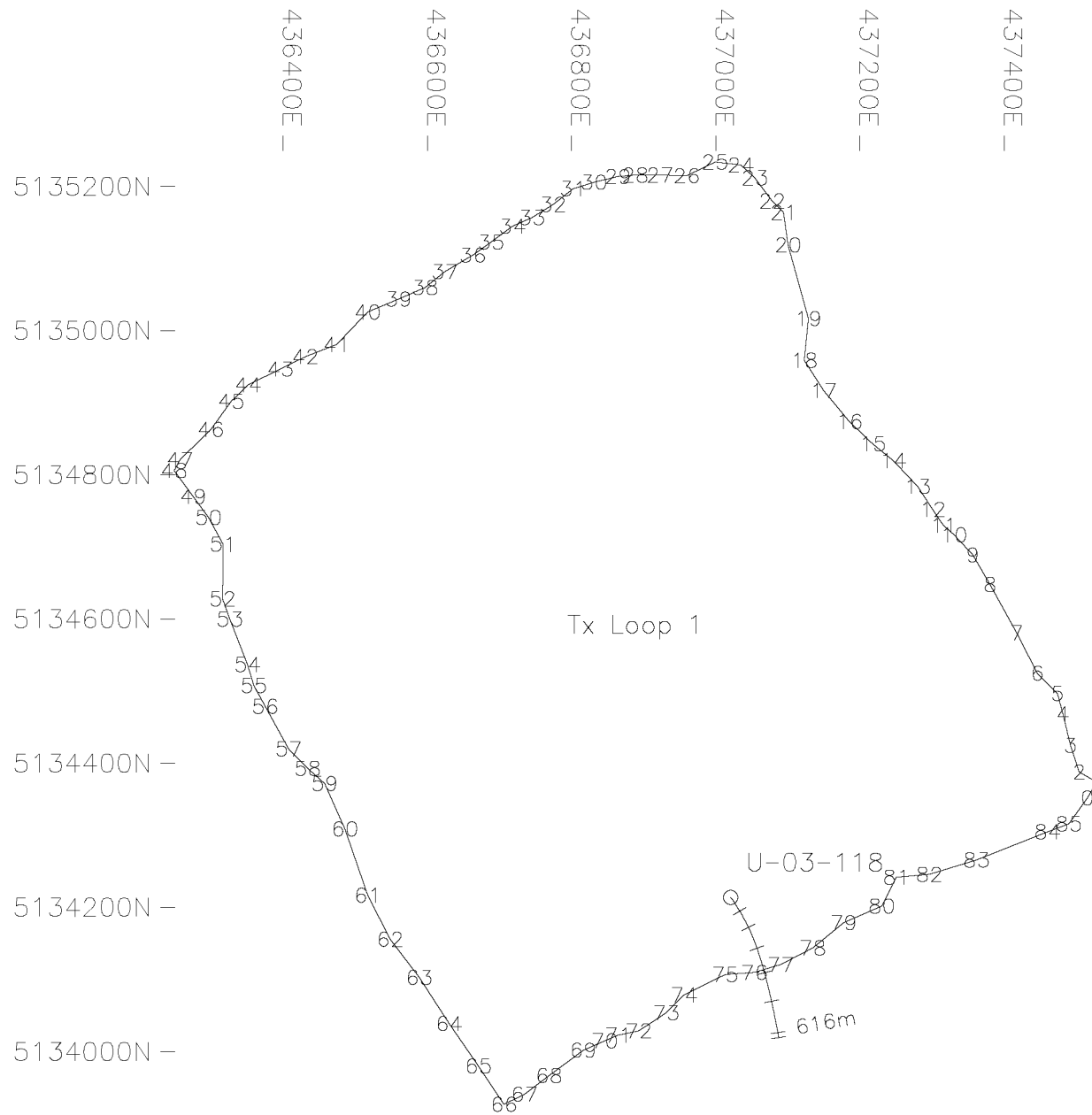

Tx Loop 1

U-03-118
616m

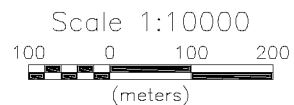
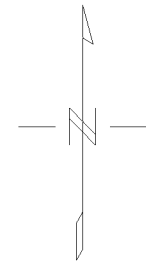

<p><i>Ursa Major Minerals Inc.</i> Shakespeare East Property</p>
<p>3-D Borehole Pulse EM Survey Borehole & Loop Location Map</p>
<p>Hole: U-03-118 Survey Date: June 10, 2011</p>
<p><i>Crone Geophysics & Exploration Ltd.</i></p>

436970E, 5134428N

U-03-118

437138E, 5133849N

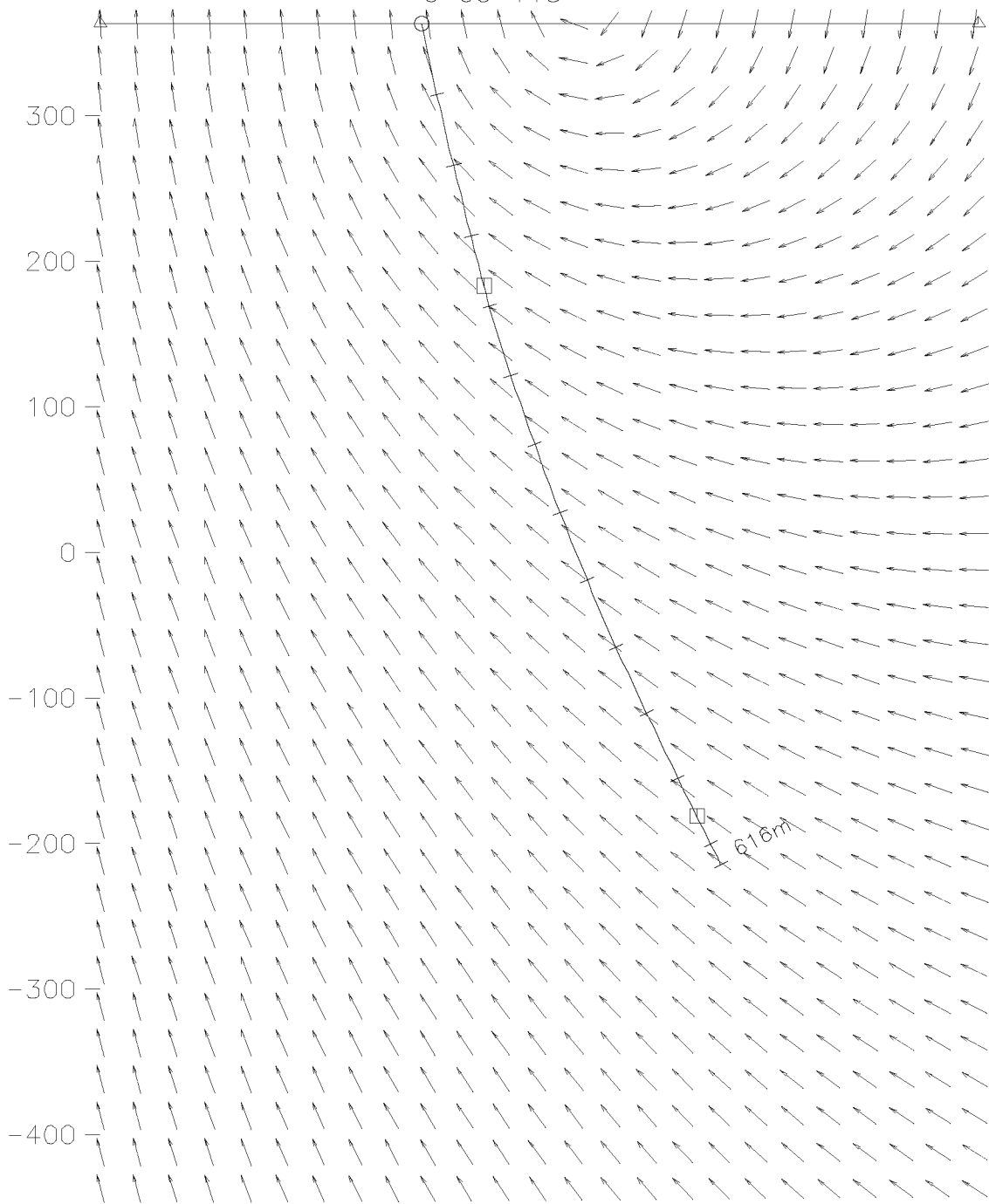

Ursa Major Minerals Inc.
Shakespeare East Property

3-D Borehole Pulse EM Survey
Hole Section with Primary Field

Hole: U-03-118

Survey Date: June 10, 2011

Crone Geophysics & Exploration Ltd.

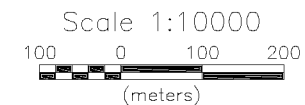
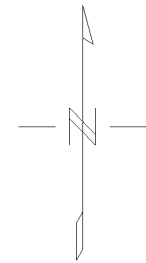
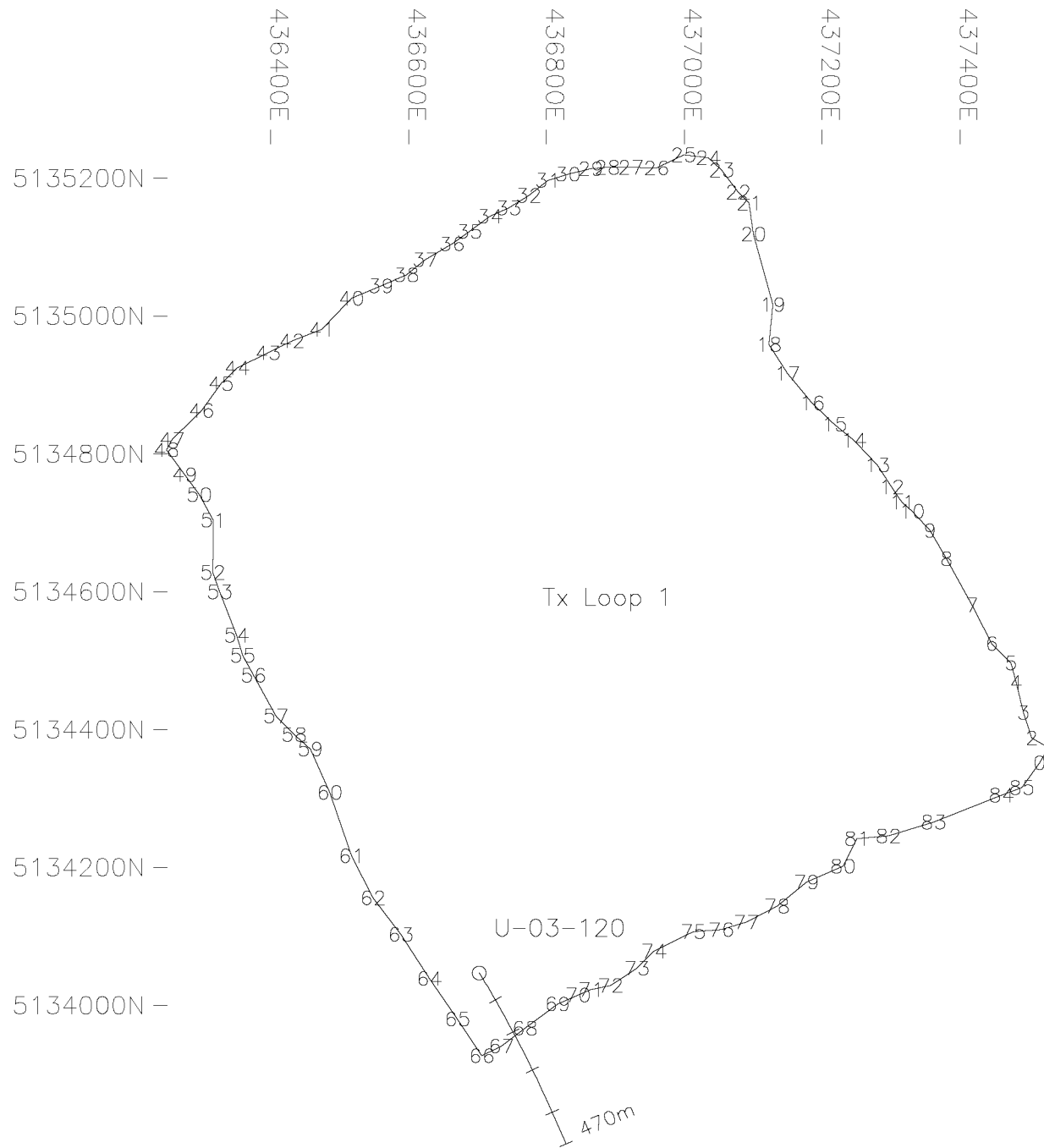

<p><i>Ursa Major Minerals Inc.</i> Shakespeare East Property</p>
<p>3-D Borehole Pulse EM Survey Borehole & Loop Location Map</p>
<p>Hole: U-03-120 Survey Date: June 15, 2011</p>
<p><i>Crone Geophysics & Exploration Ltd.</i></p>

436625E, 5134209N

U-03-120

436894E, 5133671N

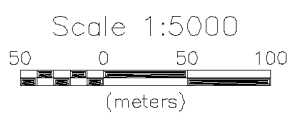
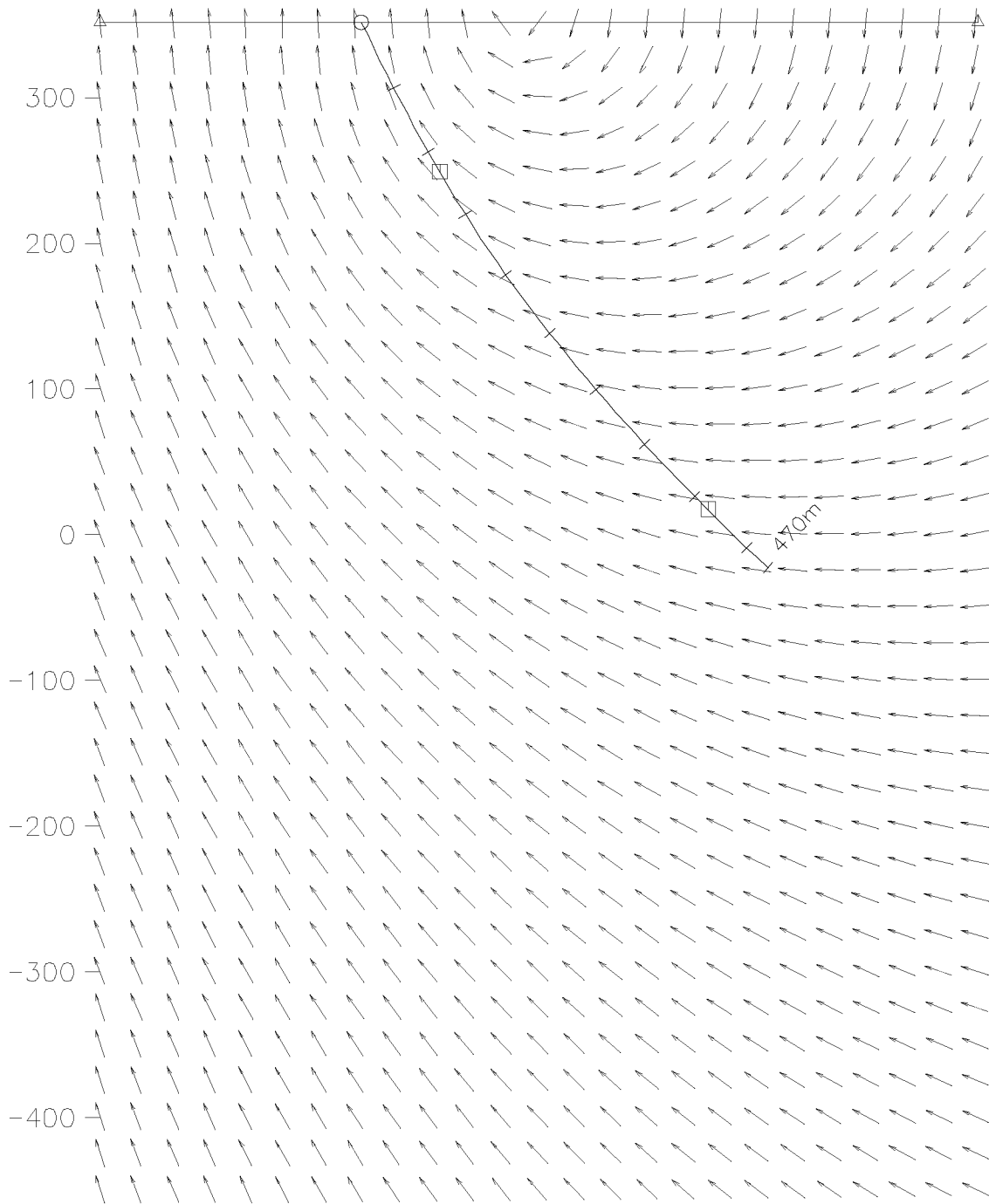

Ursa Major Minerals Inc.
Shakespeare East Property

3-D Borehole Pulse EM Survey
Hole Section with Primary Field

Hole: U-03-120

Survey Date: June 15, 2011

Crone Geophysics & Exploration Ltd.

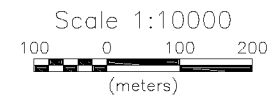
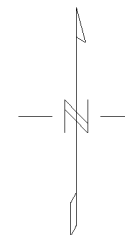

Ursa Major Minerals Inc.
 Shakespeare East Property
 3-D Borehole Pulse EM Survey
 Borehole & Loop Location Map
 Hole: U-03-121
 Survey Date: June 20, 2011
Crone Geophysics & Exploration Ltd.

436579E, 5134187N

U-03-121

436766E, 5133612N

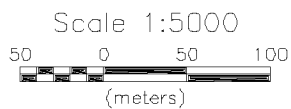
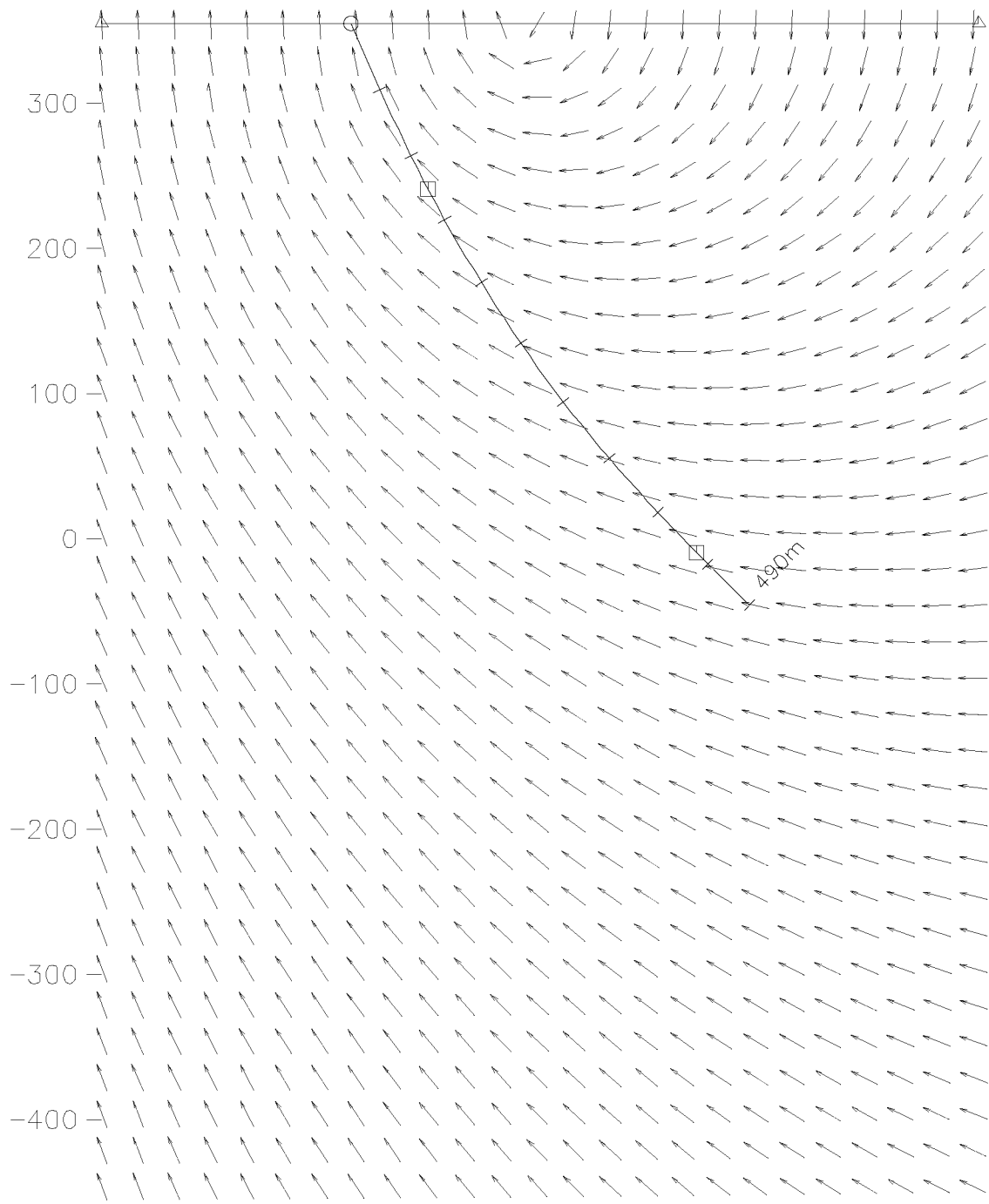

Ursa Major Minerals Inc.
Shakespeare East Property

3-D Borehole Pulse EM Survey
Hole Section with Primary Field

Hole: U-03-121

Survey Date: June 20, 2011

Crone Geophysics & Exploration Ltd.

APPENDIX II
LINEAR (5-AXIS) PULSE EM DATA PROFILES



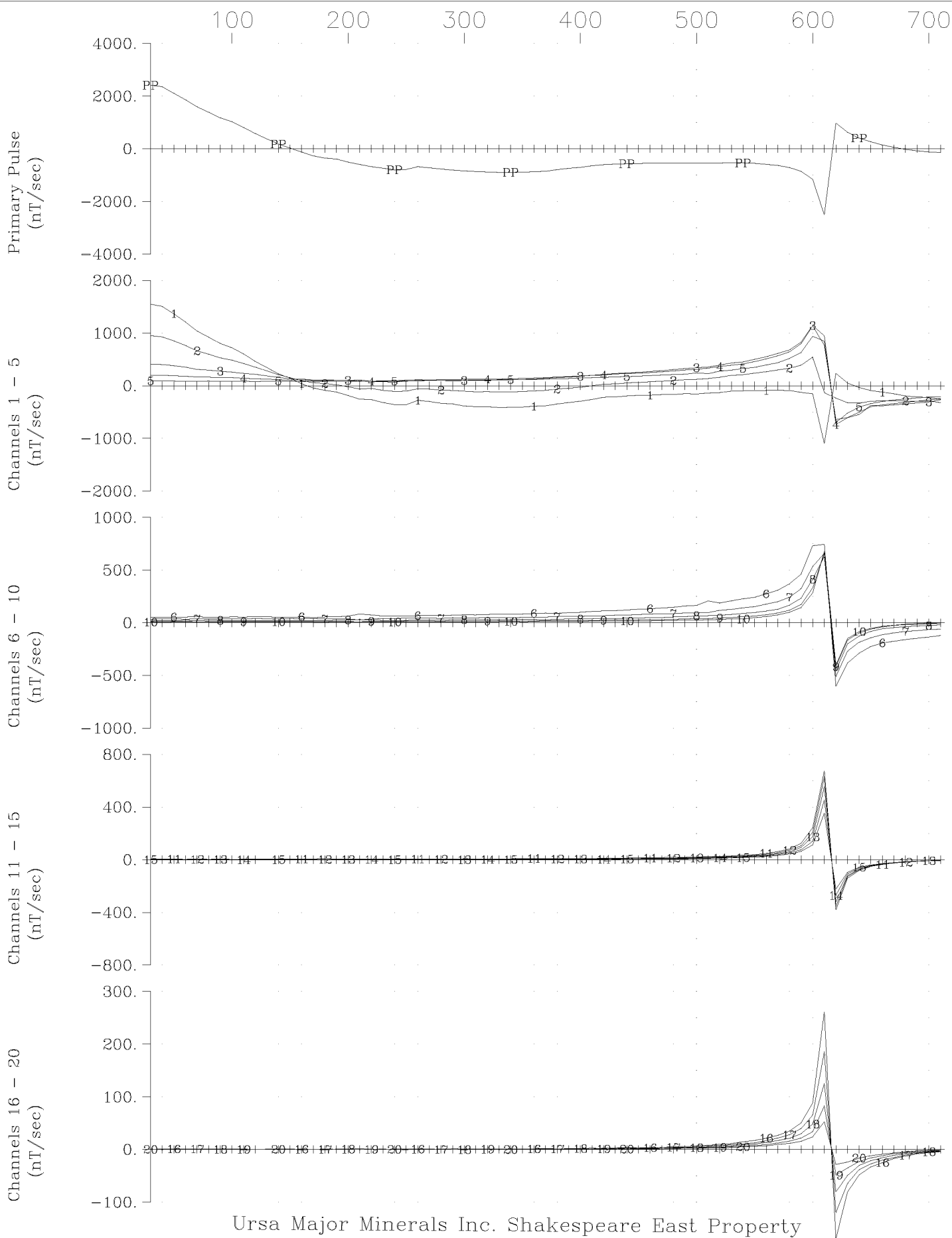

Ursa Major Minerals Inc. Shakespeare East Property
 Loop 1, Hole U-08-02 X Component
 Crone Geophysics & Exploration Ltd.

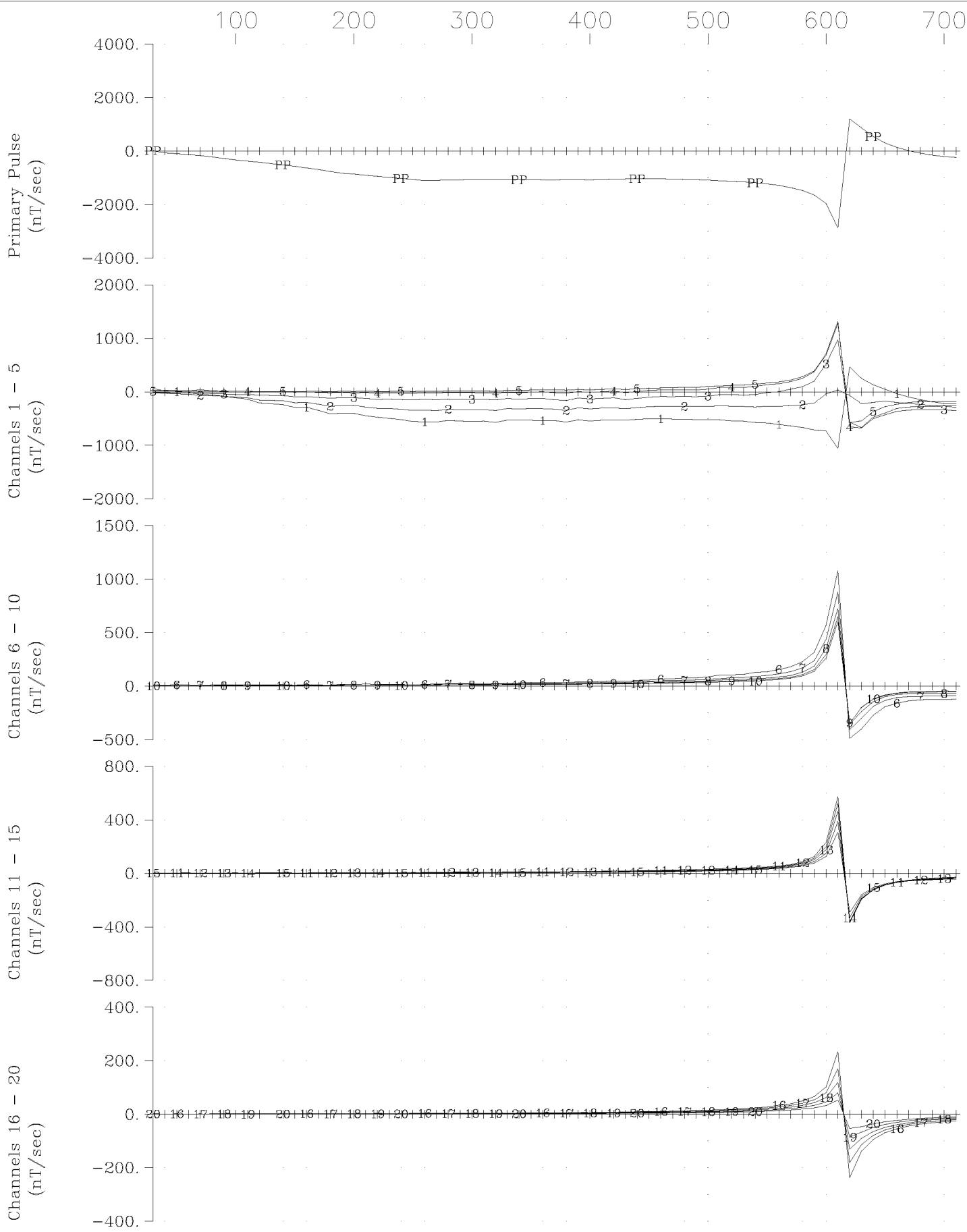

Ursa Major Minerals Inc. Shakespeare East Property
 Loop 1, Hole U-08-02 Y Component
 Crone Geophysics & Exploration Ltd.

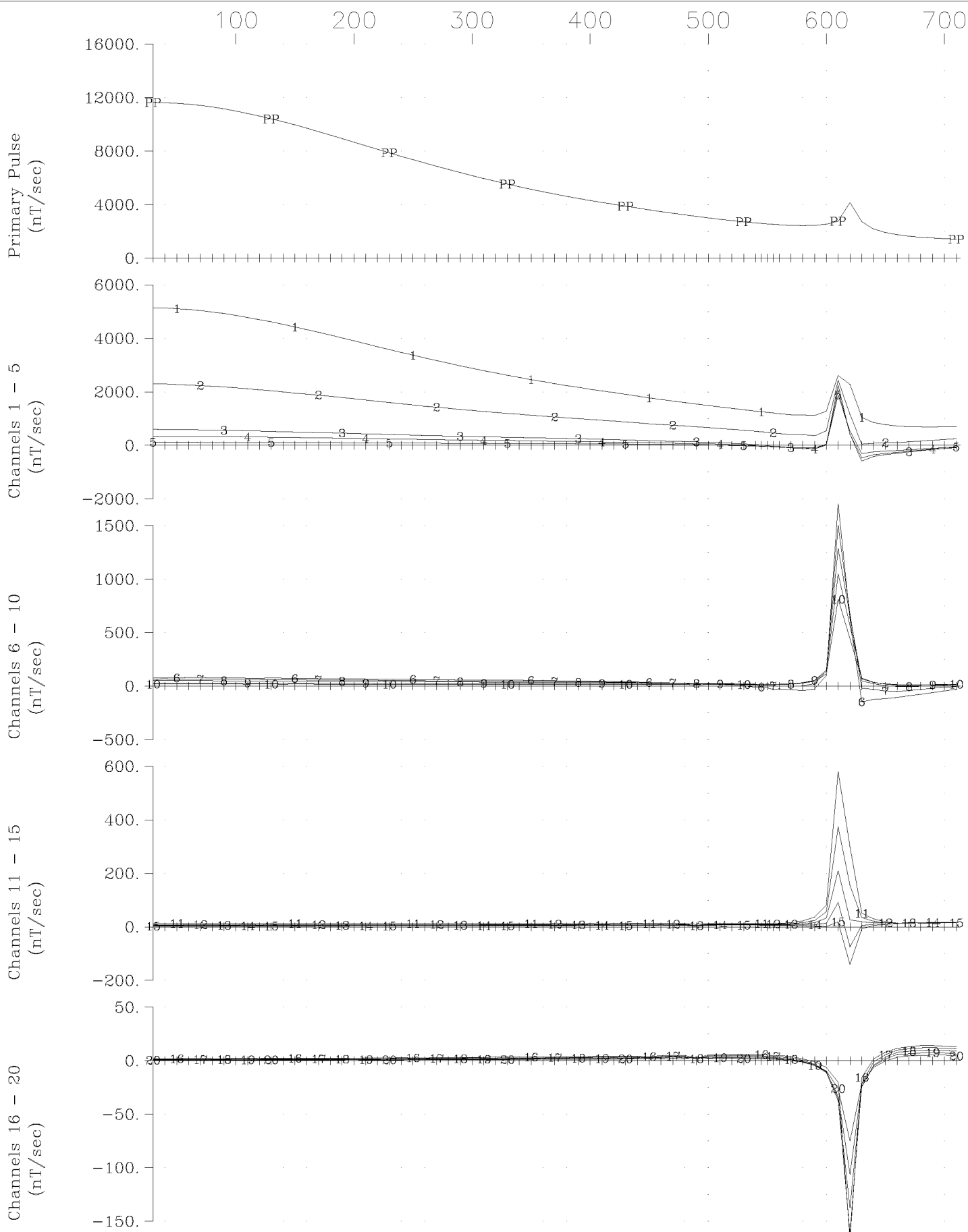

Ursa Major Minerals Inc. Shakespeare East Property
 Loop 1, Hole U-08-02 Z Component
 Crone Geophysics & Exploration Ltd.

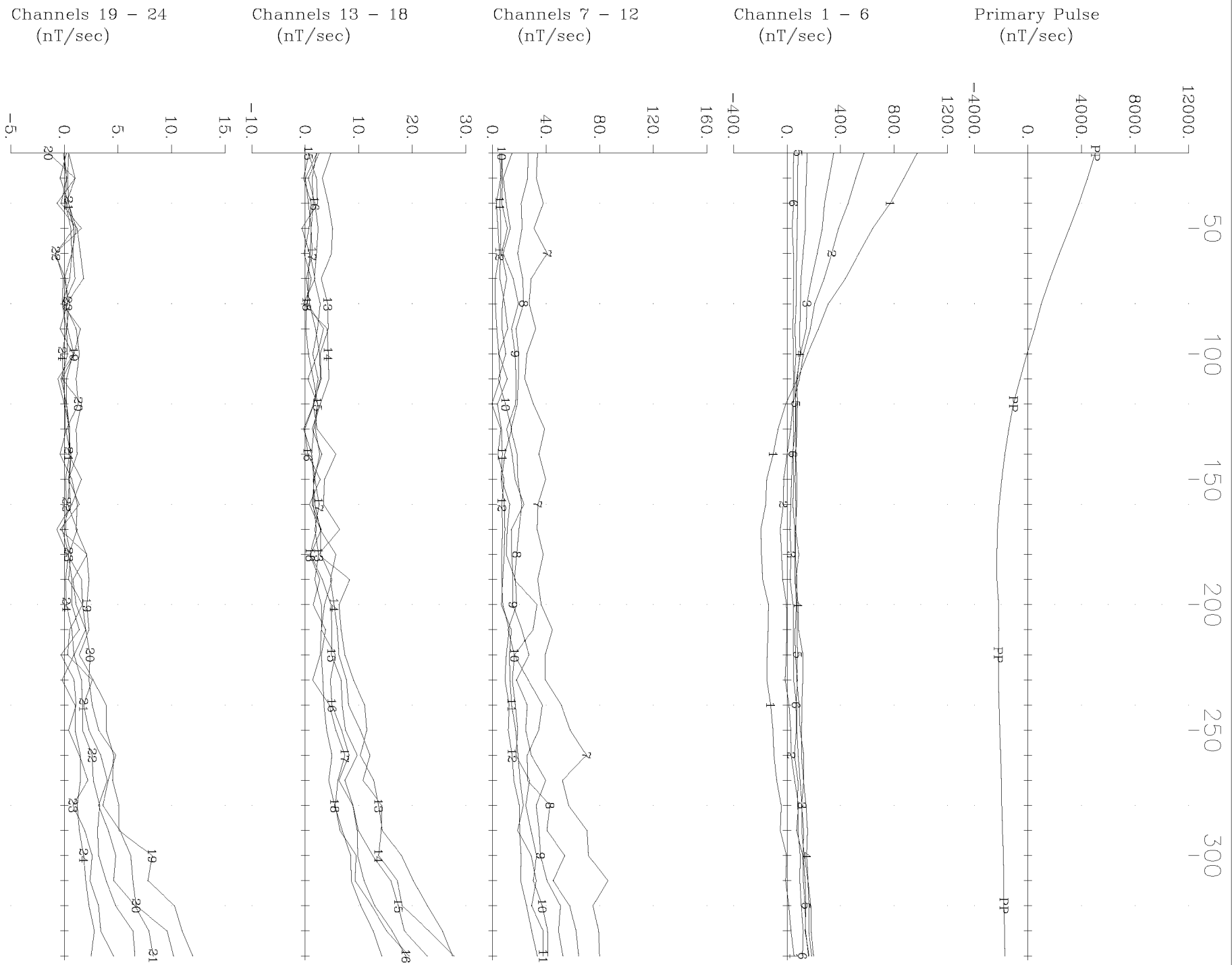

Ursa Major Minerals Inc. Shakespeare East Property
 Loop 1, Hole U-03-113 X Component
 Crone Geophysics & Exploration Ltd.

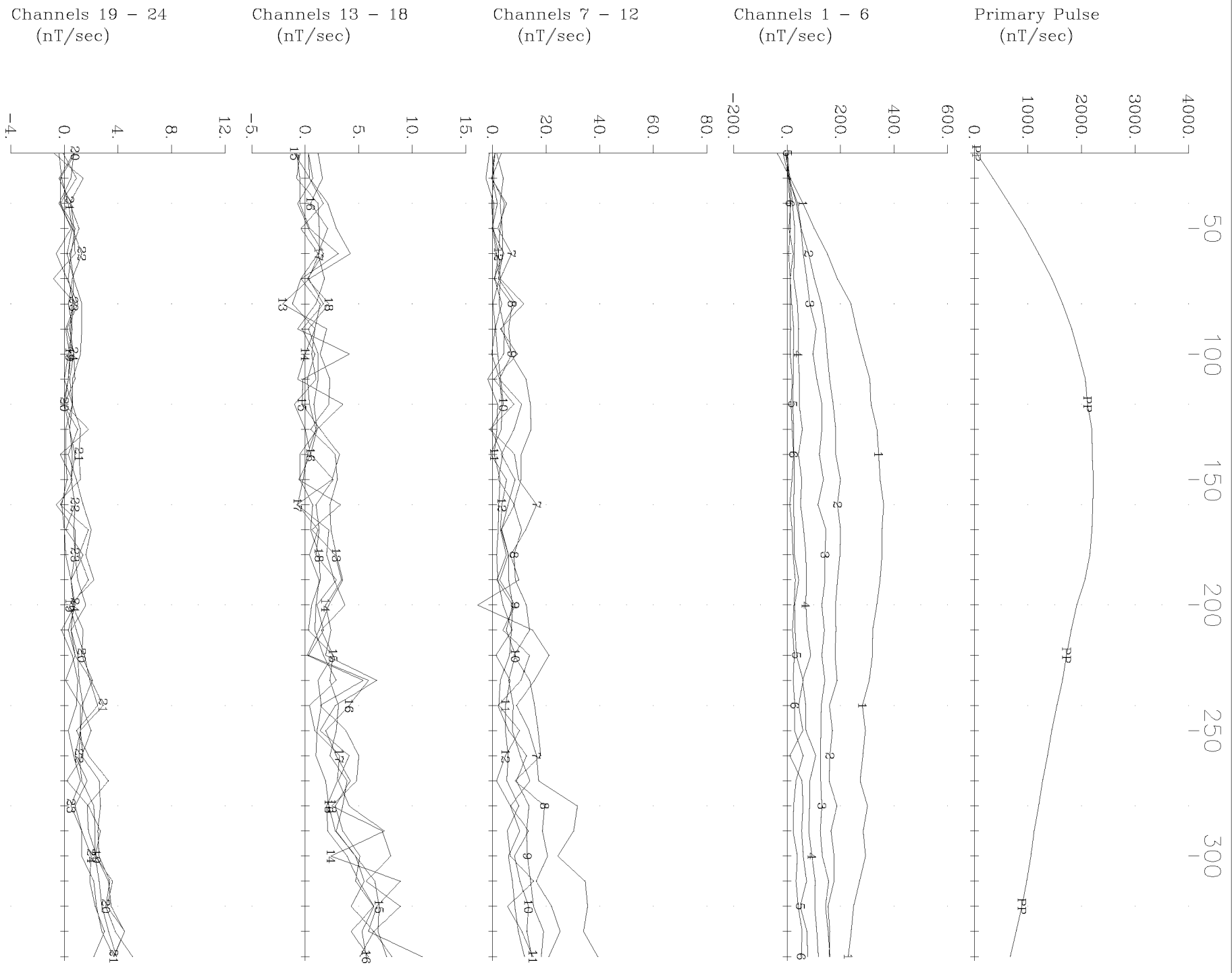

Ursa Major Minerals Inc. Shakespeare East Property
 Loop 1, Hole U-03-113 Y Component
 Crone Geophysics & Exploration Ltd.

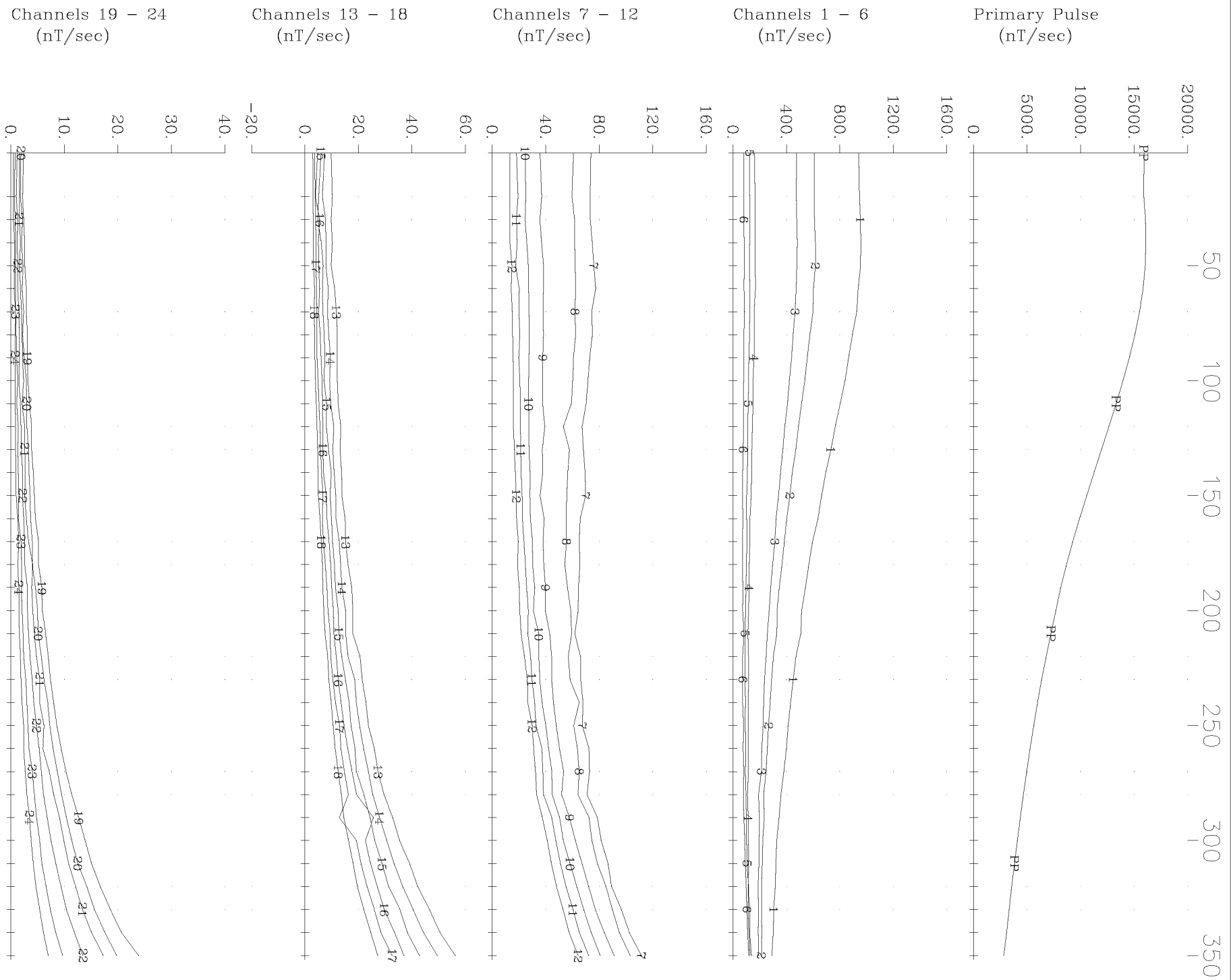

Ursa Major Minerals Inc. Shakespeare East Property
 Loop 1, Hole U-03-113 Z Component
 Crone Geophysics & Exploration Ltd.

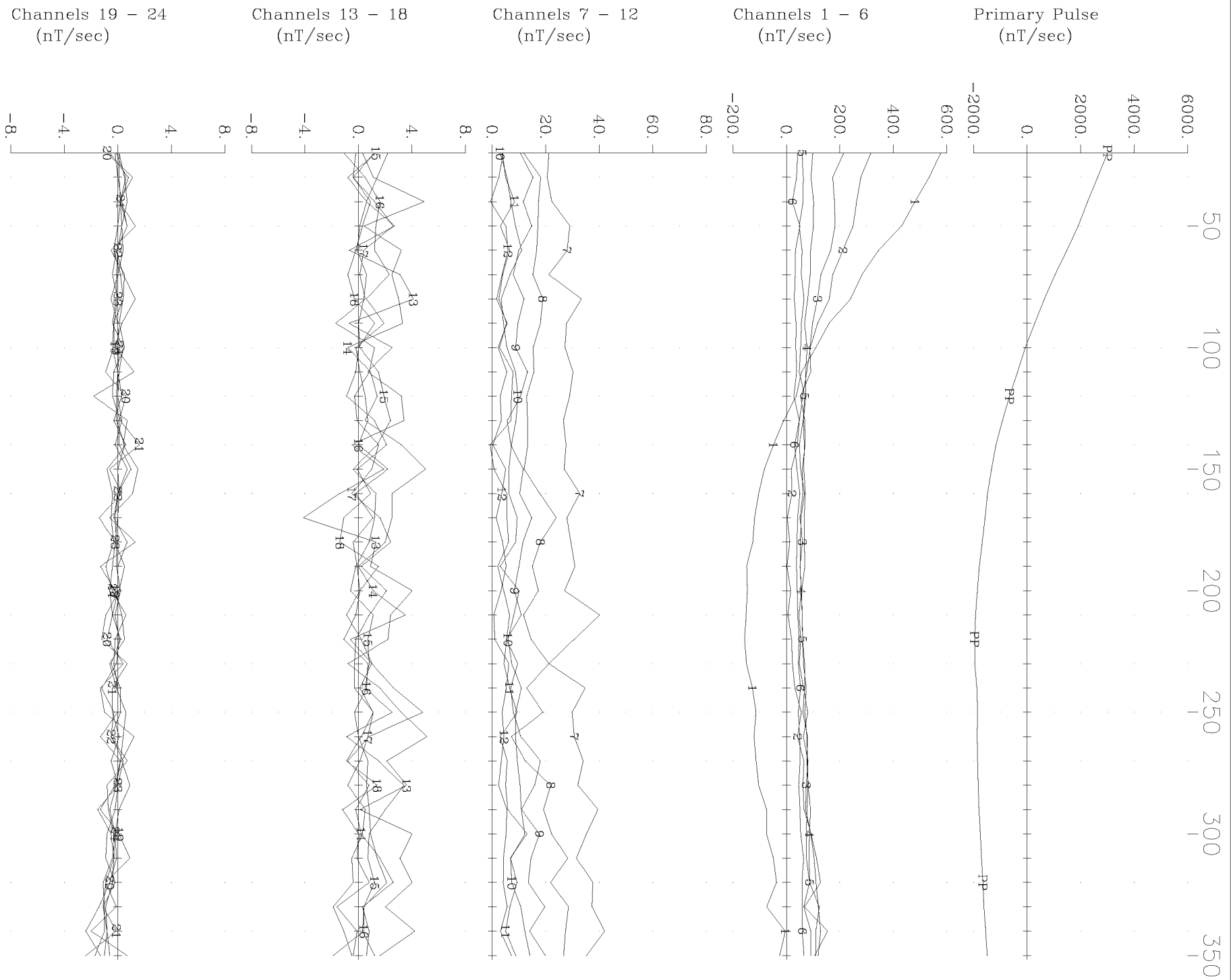

Ursa Major Minerals Inc. Shakespeare East Property
 Loop 1, Hole U-03-114 X Component
 Crone Geophysics & Exploration Ltd.

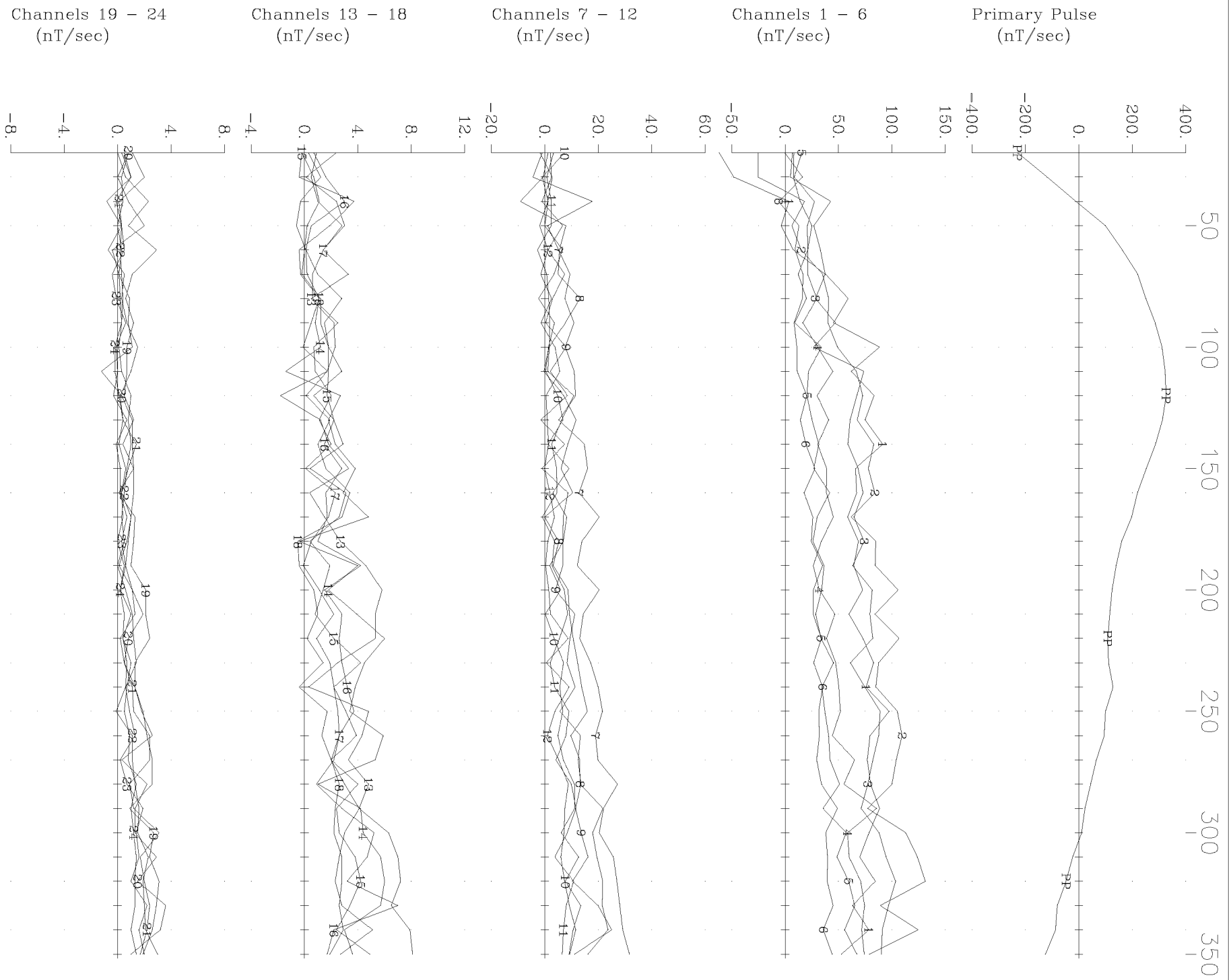

Ursa Major Minerals Inc. Shakespeare East Property
 Loop 1, Hole U-03-114 Y Component
 Crone Geophysics & Exploration Ltd.

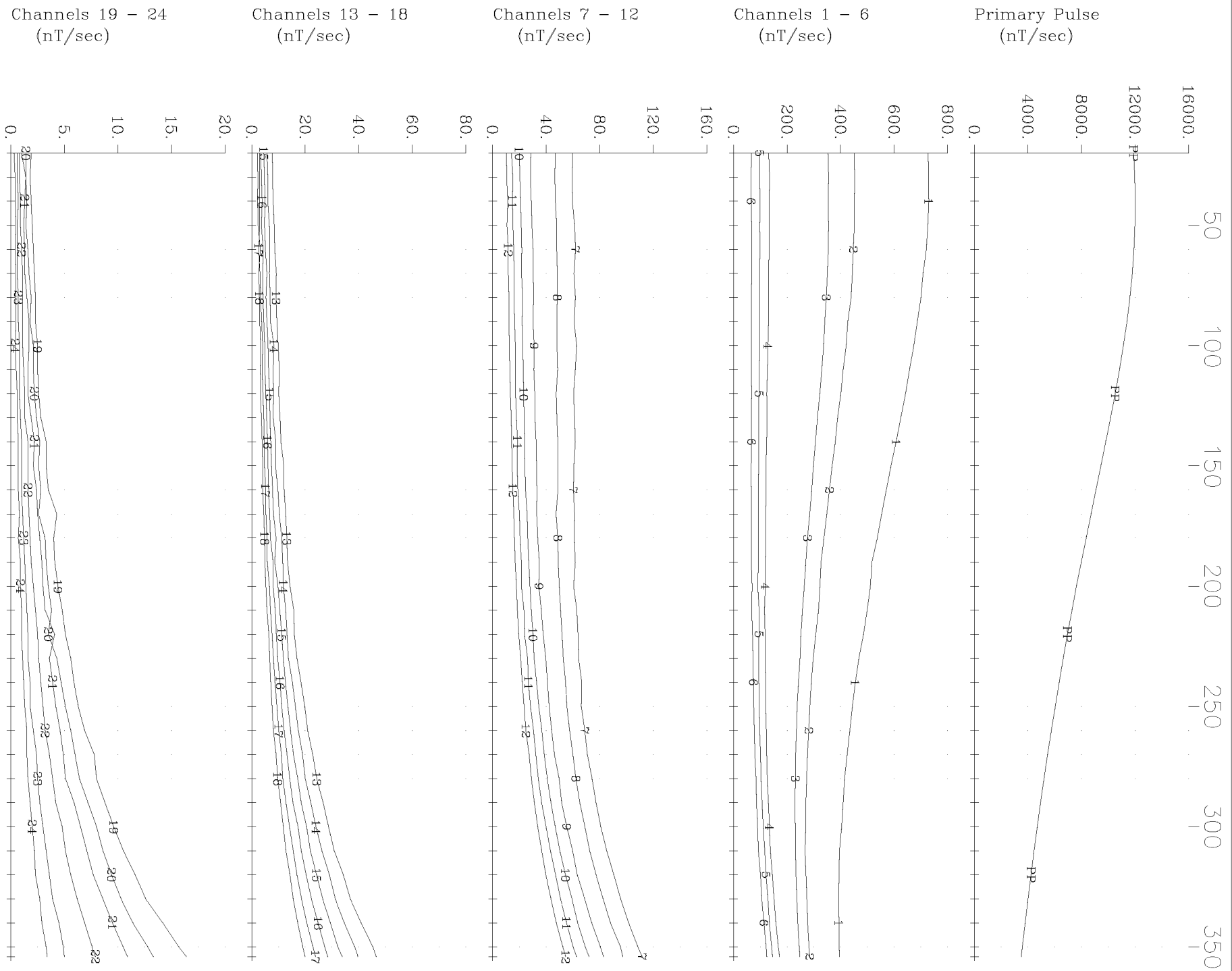

Ursa Major Minerals Inc. Shakespeare East Property
 Loop 1, Hole U-03-114 Z Component
 Crone Geophysics & Exploration Ltd.

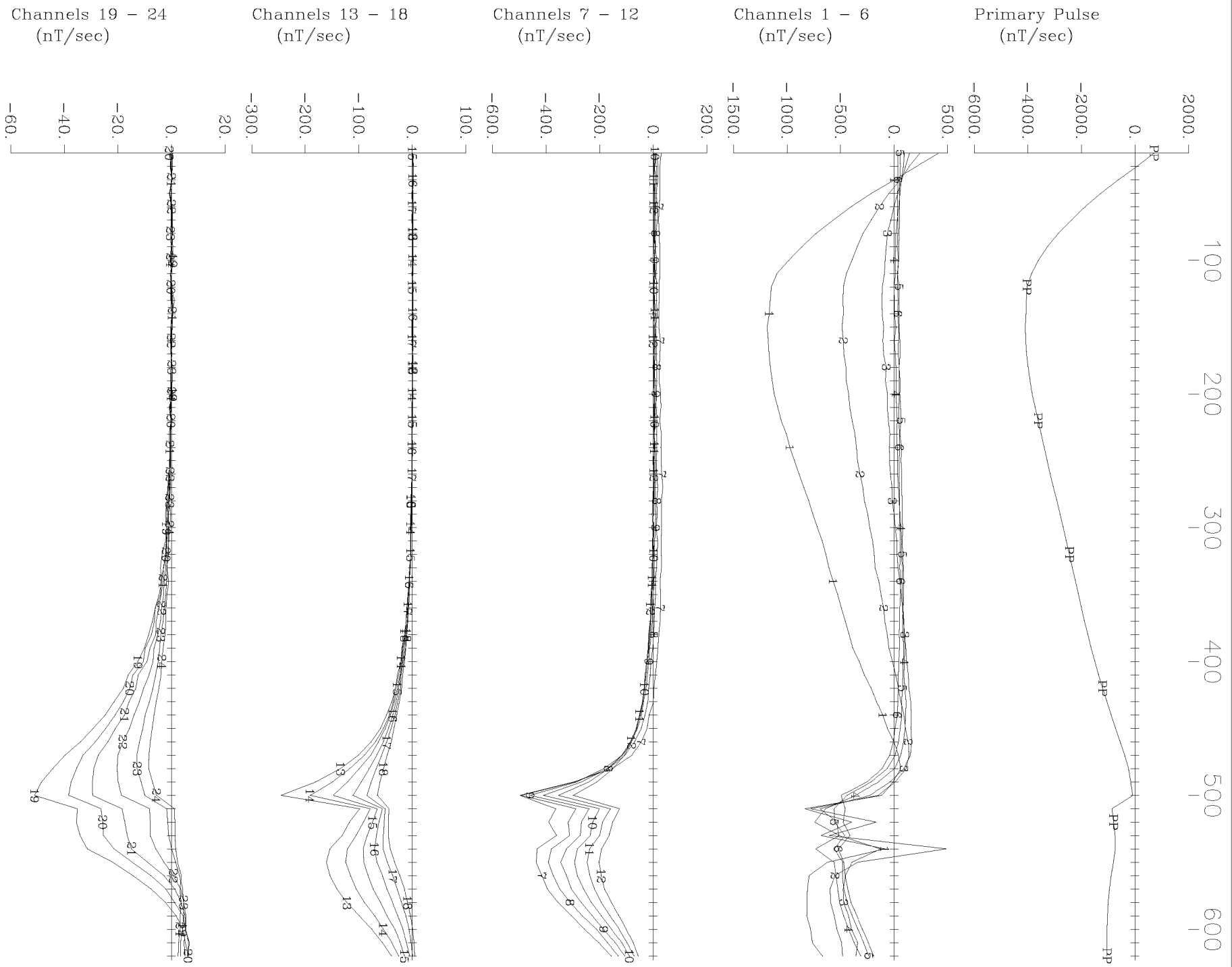

Ursa Major Minerals Inc. Shakespeare East Property
 Loop 1, Hole U-03-116 X Component
 Crone Geophysics & Exploration Ltd.

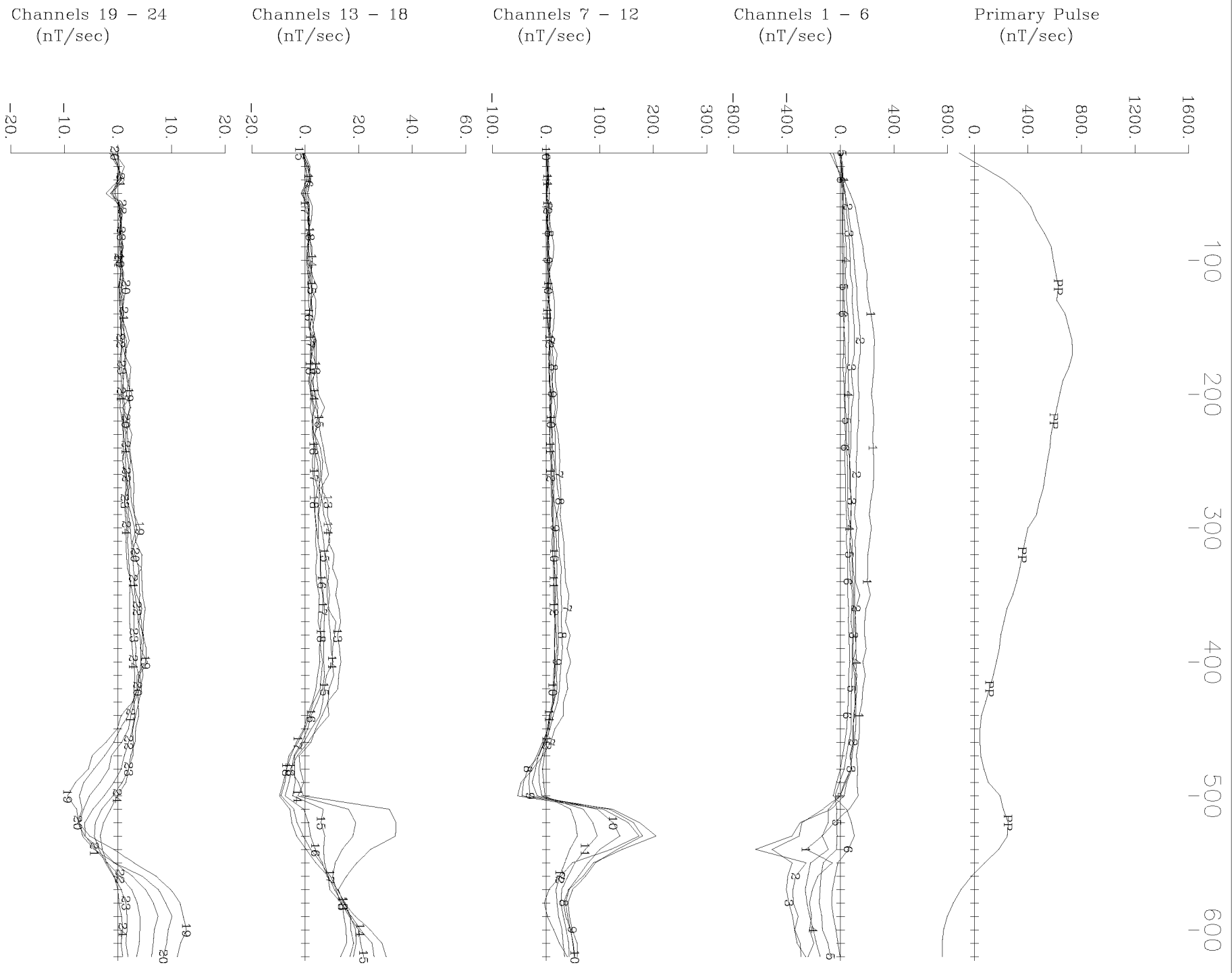

Urša Major Minerals Inc. Shakespeare East Property
 Loop 1, Hole U-03-116 Y Component
 Crone Geophysics & Exploration Ltd.

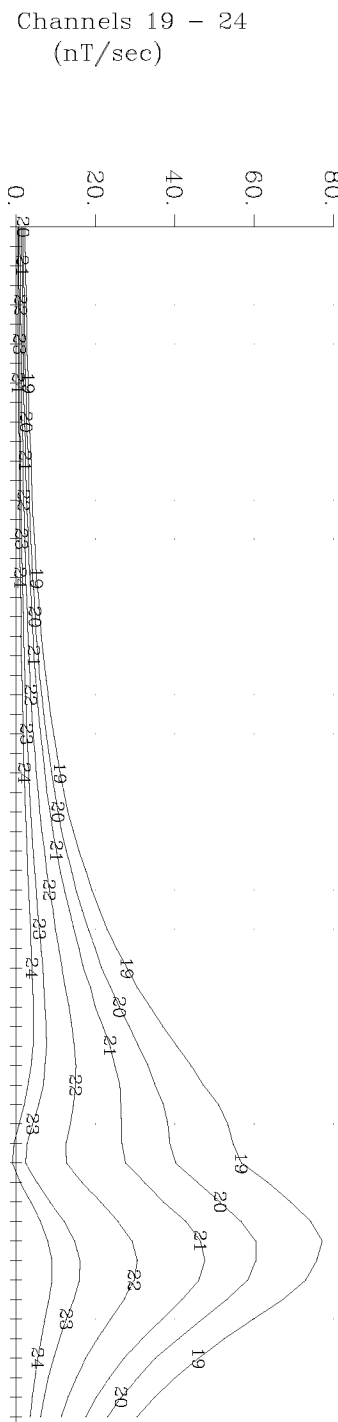
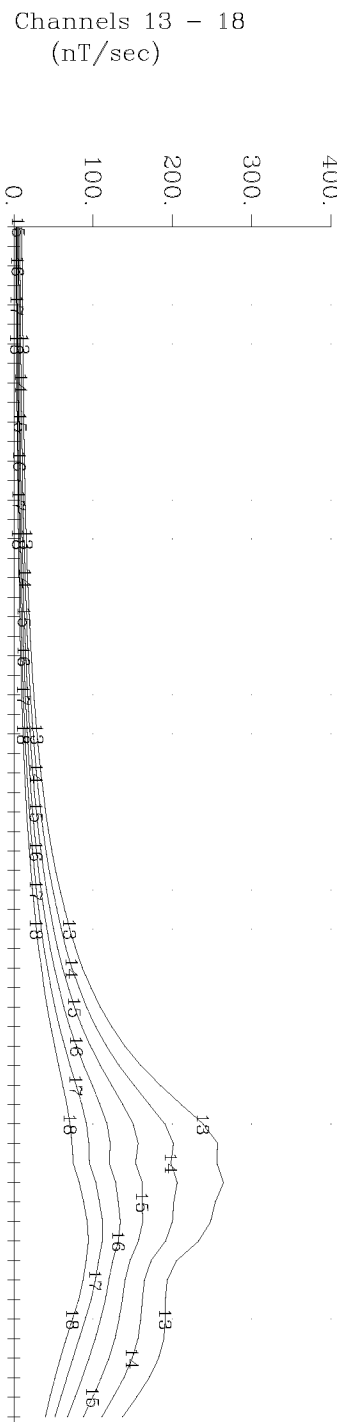
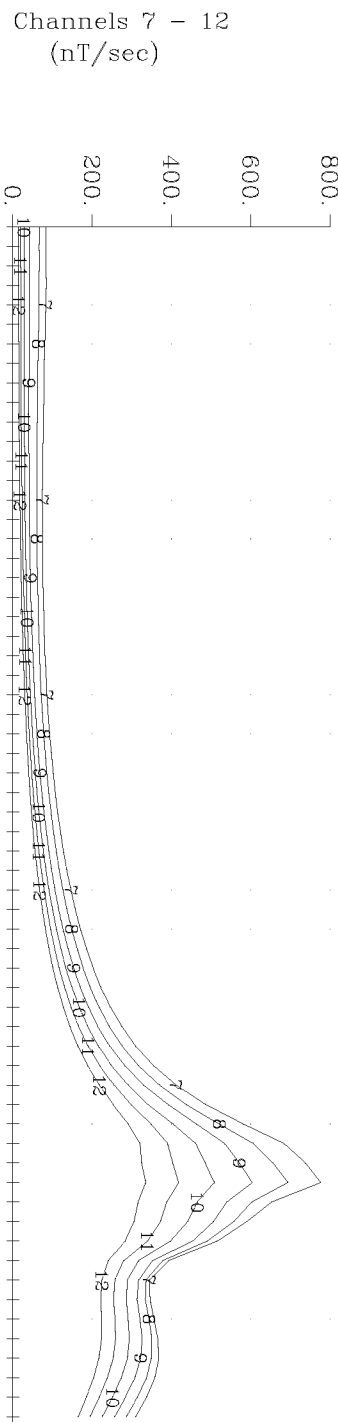
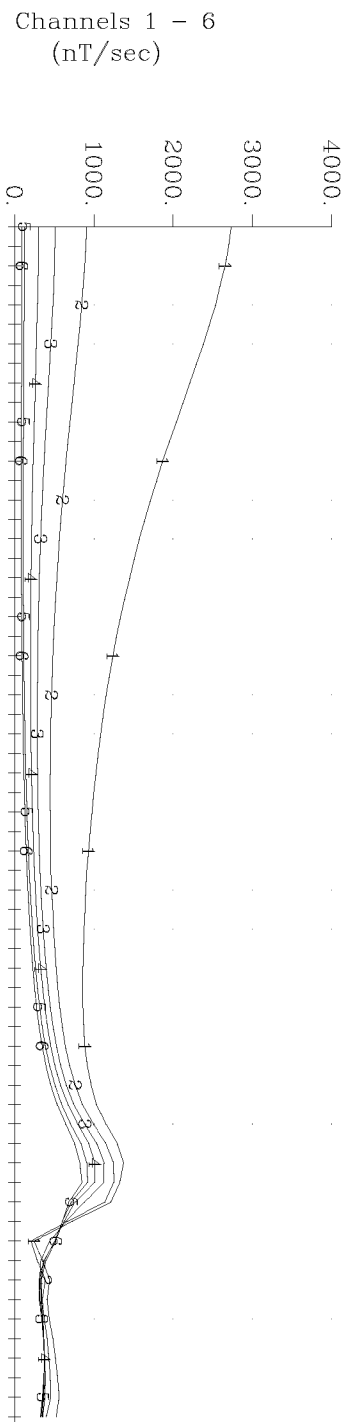
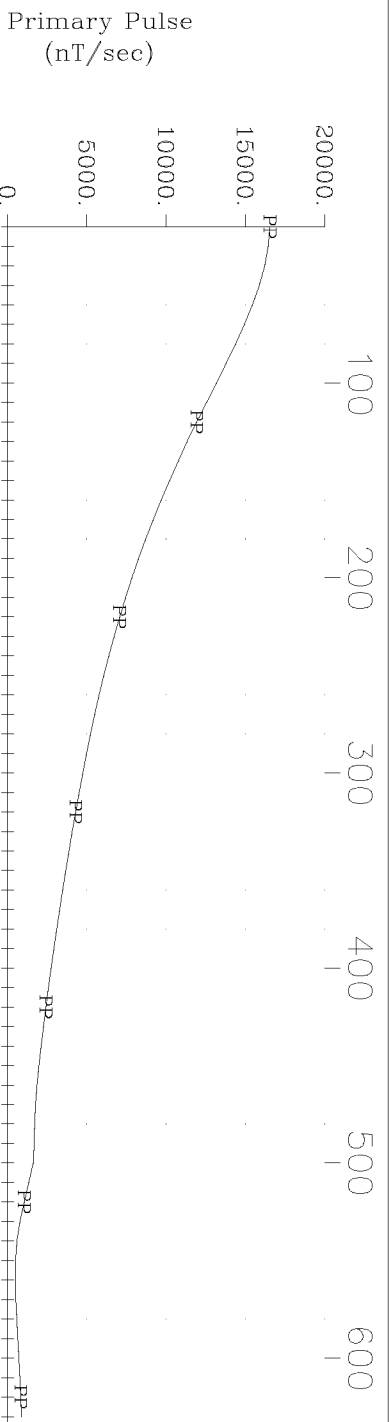

Ursa Major Minerals Inc. Shakespeare East Property
 Loop 1, Hole U-03-116 Z Component
 Crone Geophysics & Exploration Ltd.

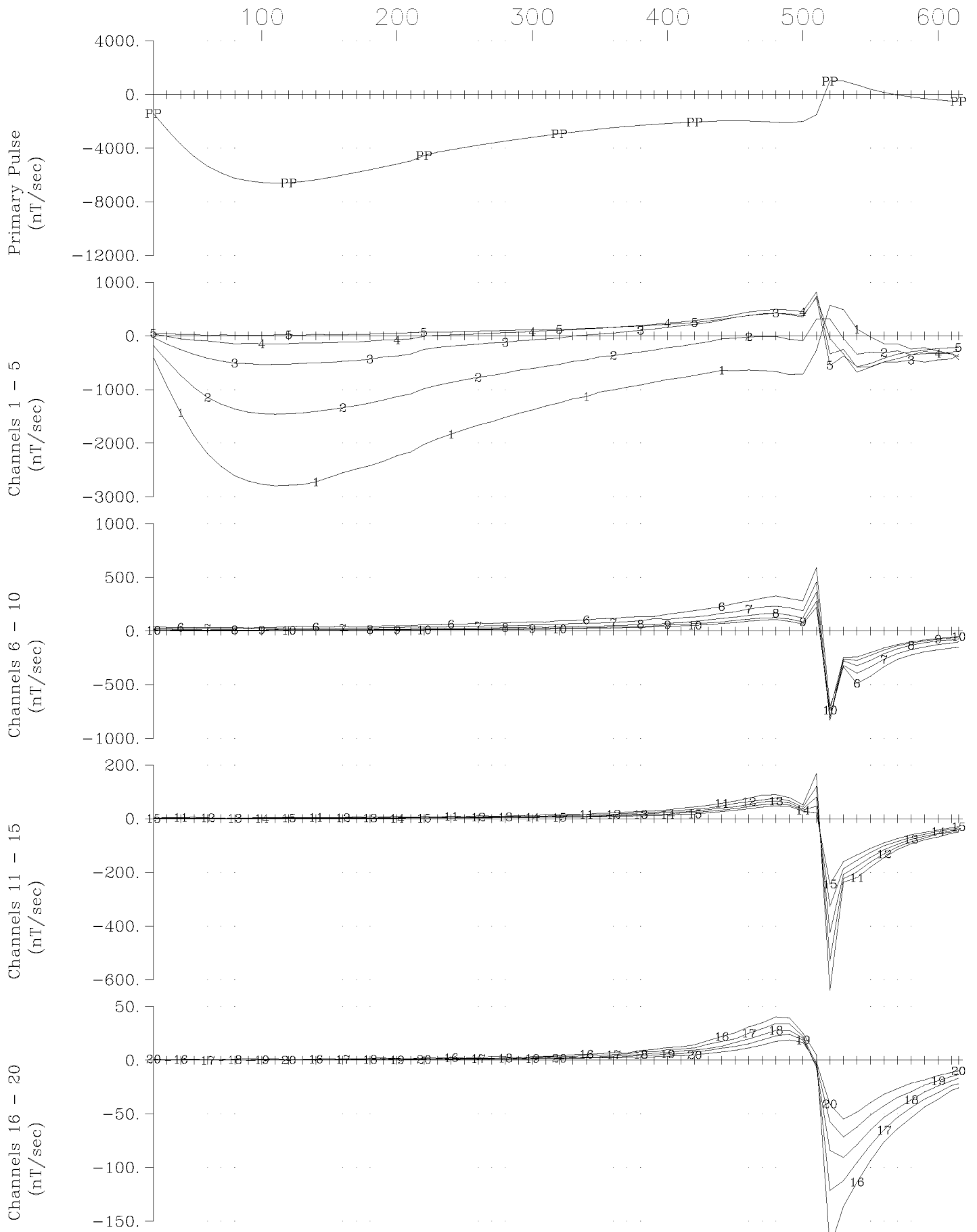

Ursa Major Minerals Inc. Shakespeare East Property
 Loop 1, Hole U-03-118 X Component
 Crone Geophysics & Exploration Ltd.

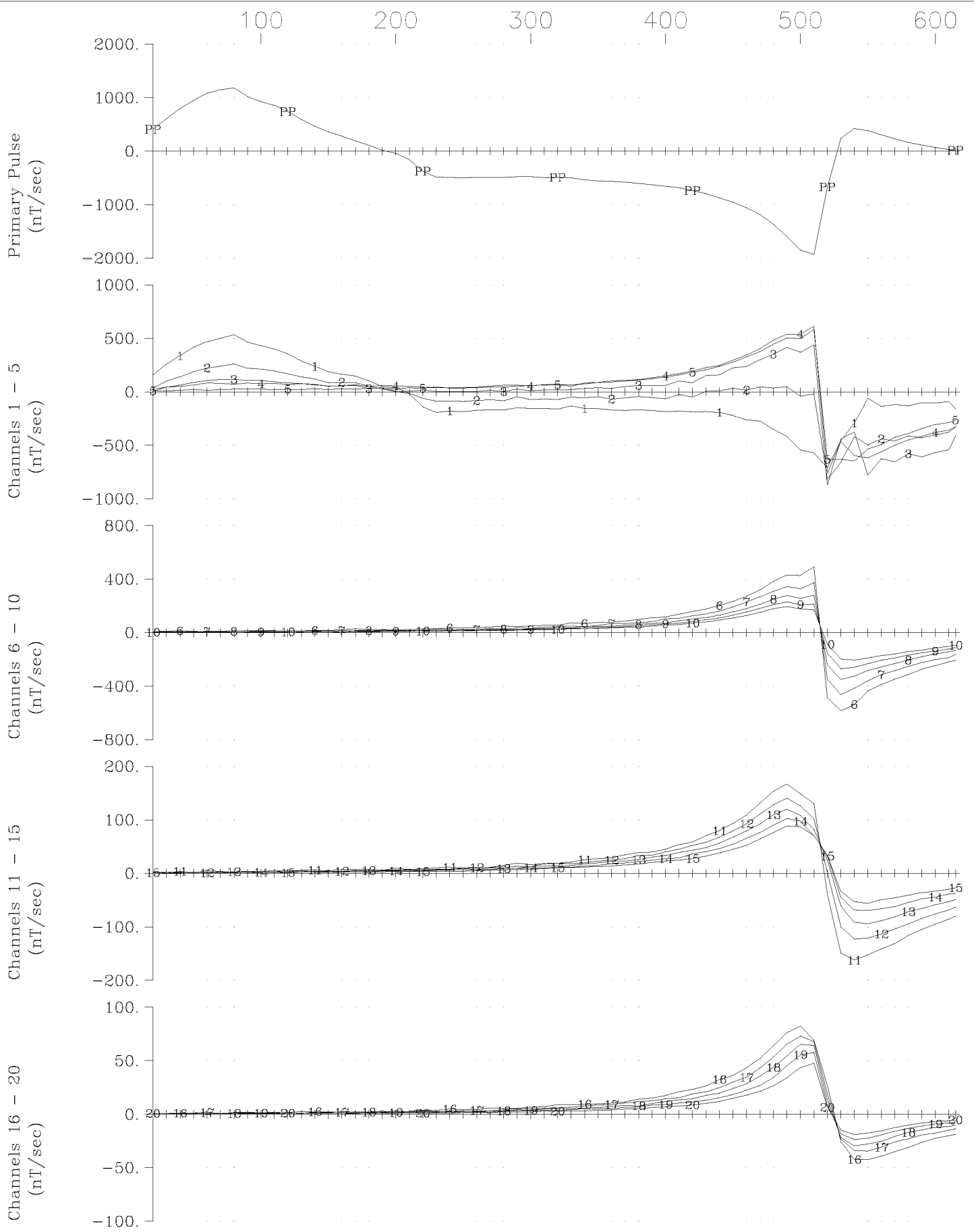

Ursa Major Minerals Inc. Shakespeare East Property
 Loop 1, Hole U-03-118 Y Component
 Crone Geophysics & Exploration Ltd.

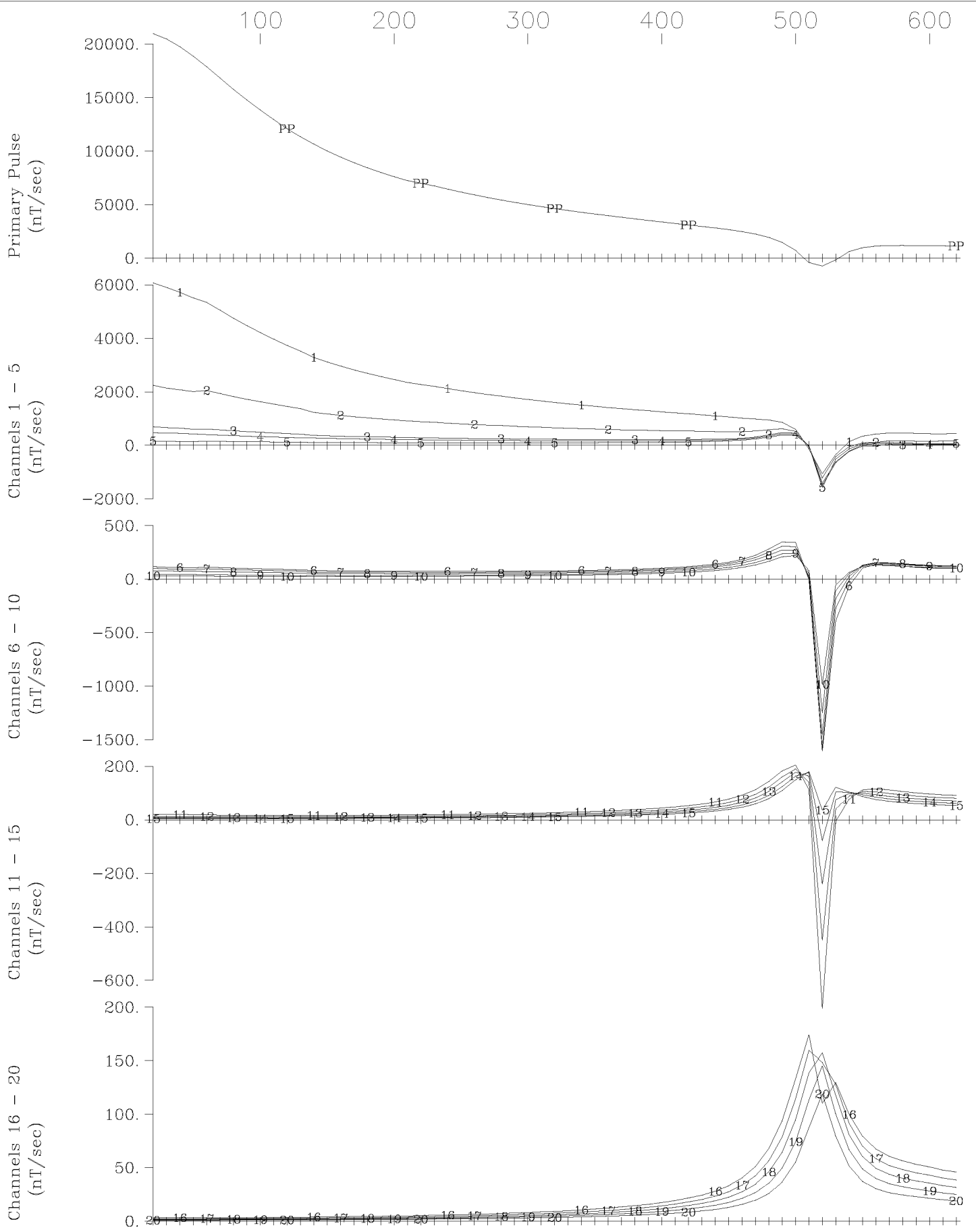

Ursa Major Minerals Inc. Shakespeare East Property
 Loop 1, Hole U-03-118 Z Component
 Crone Geophysics & Exploration Ltd.

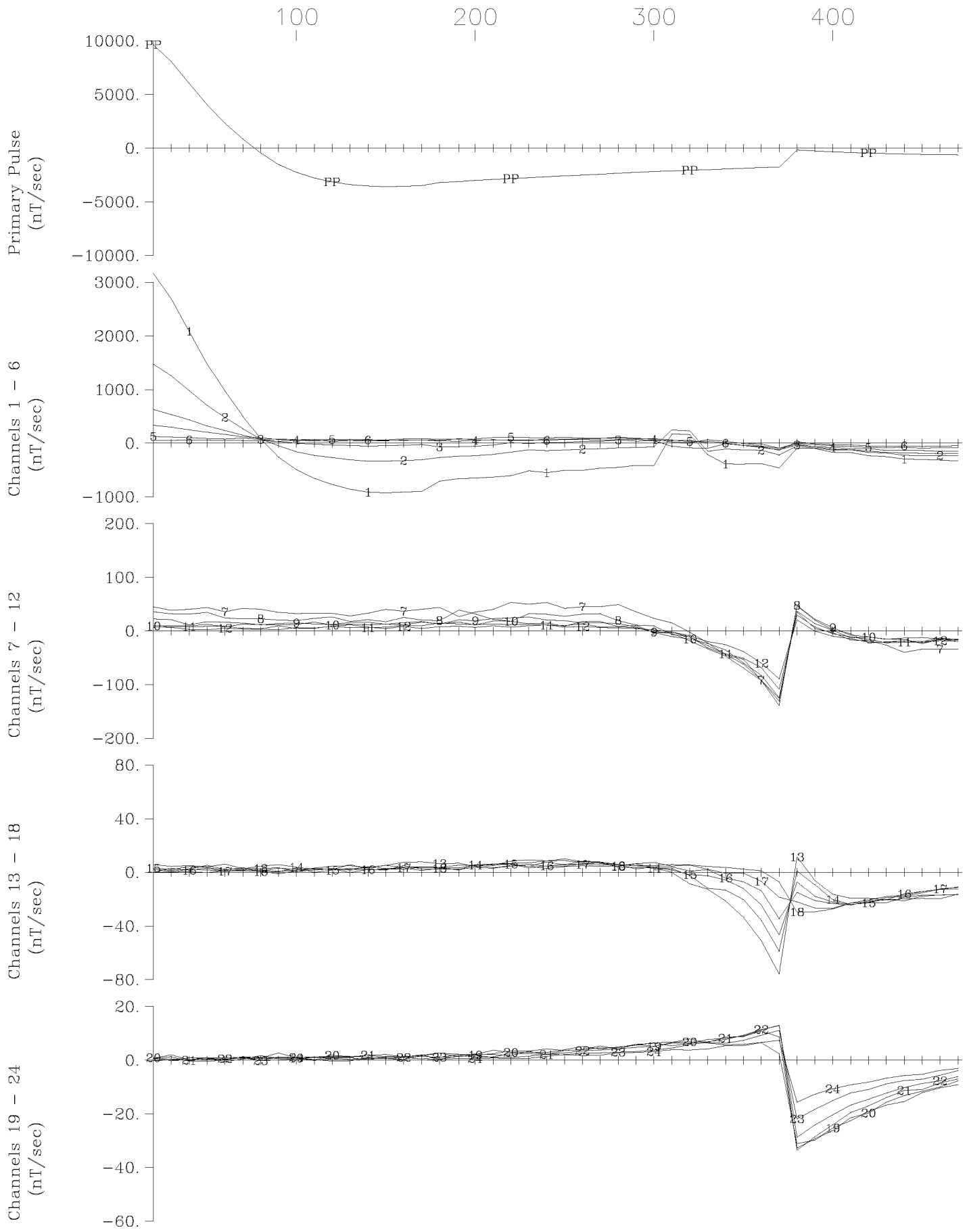

Ursa Major Minerals Inc. Shakespeare East Property
 Loop 1, Hole U-03-120 X Component
 Crone Geophysics & Exploration Ltd.

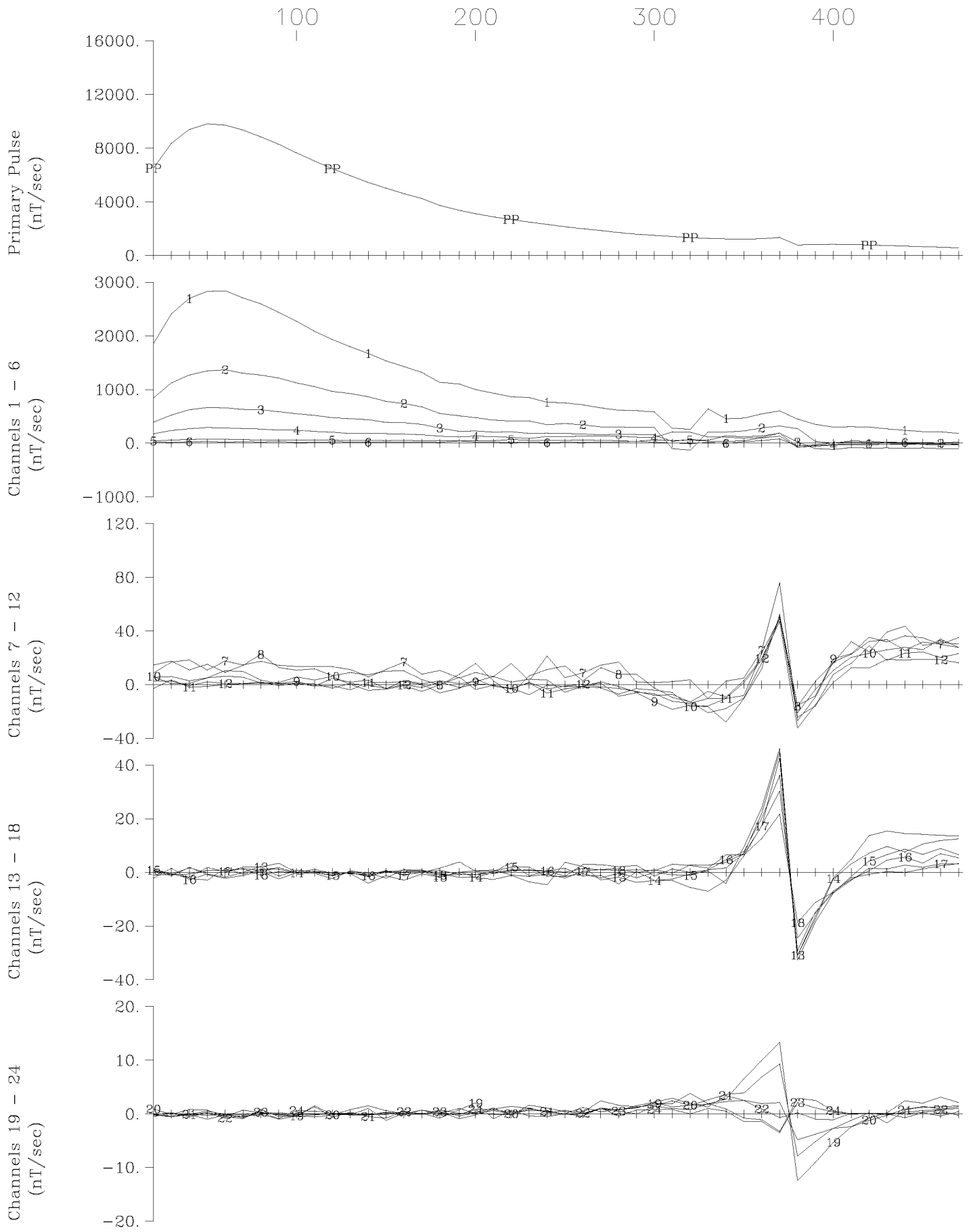

Ursa Major Minerals Inc. Shakespeare East Property
 Loop 1, Hole U-03-120 Y Component
 Crone Geophysics & Exploration Ltd.

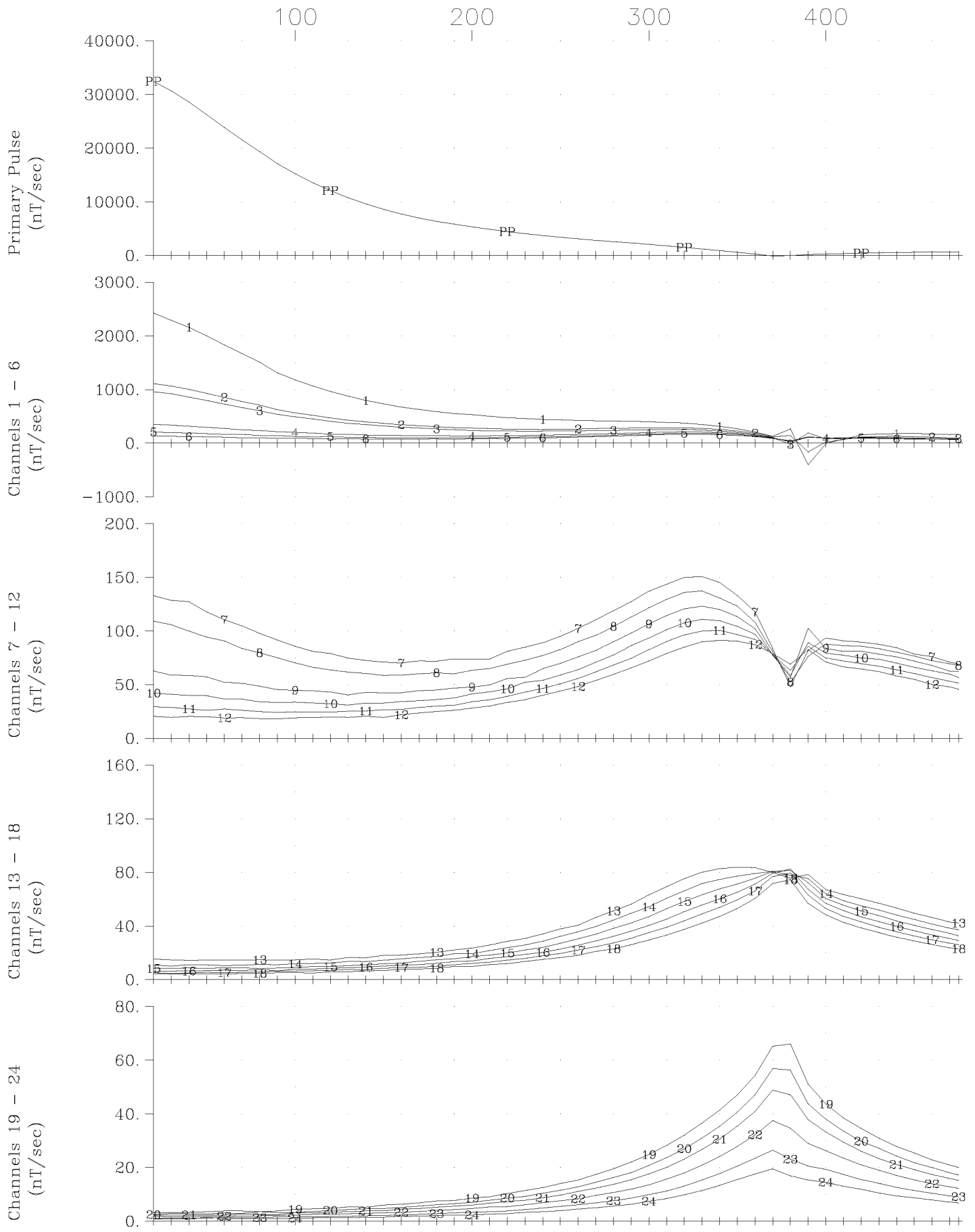

Ursa Major Minerals Inc. Shakespeare East Property
 Loop 1, Hole U-03-120 Z Component
 Crone Geophysics & Exploration Ltd.

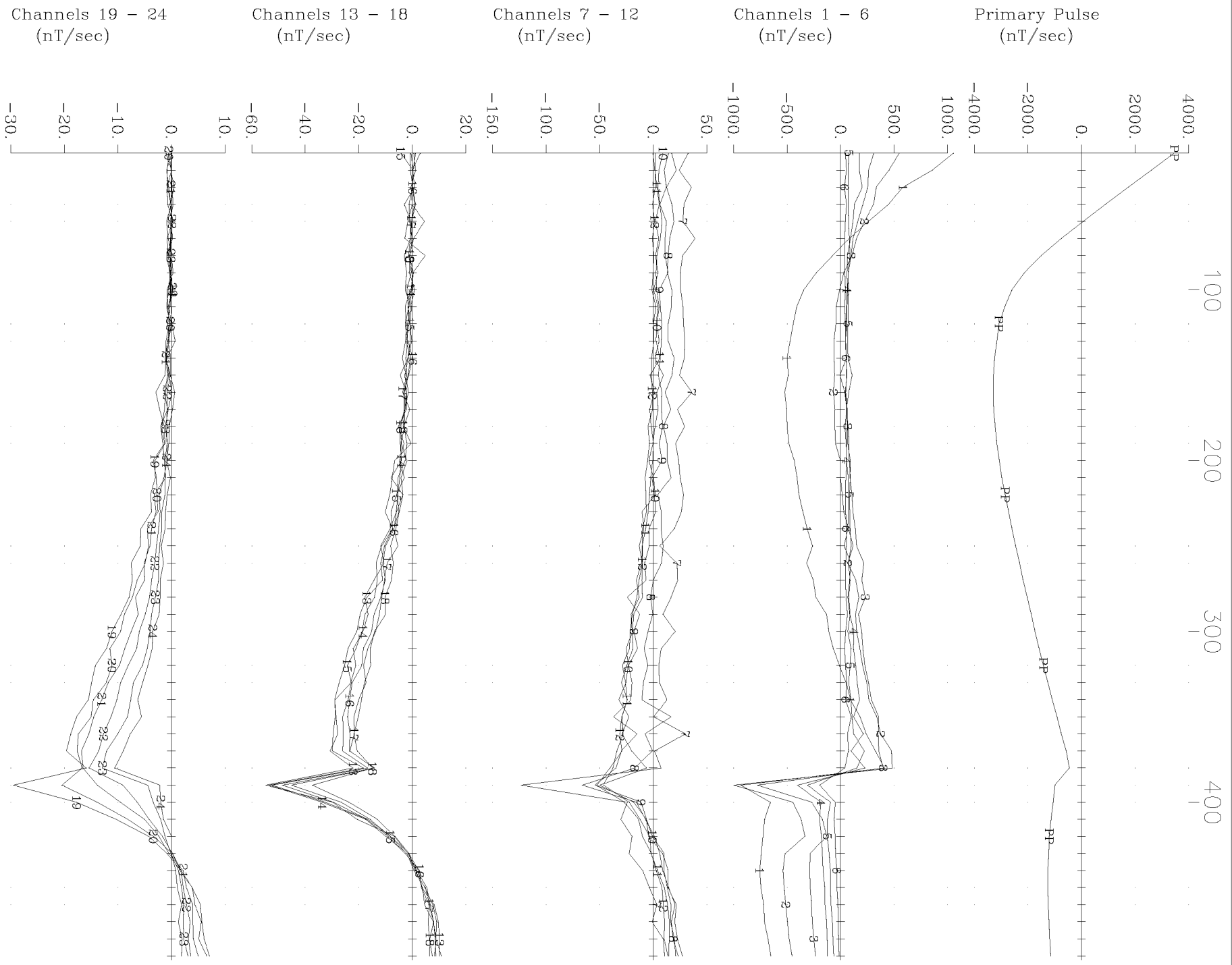

Ursa Major Minerals Inc. Shakespeare East Property
 Loop 2, Hole U-03-121 X Component
 Crone Geophysics & Exploration Ltd.

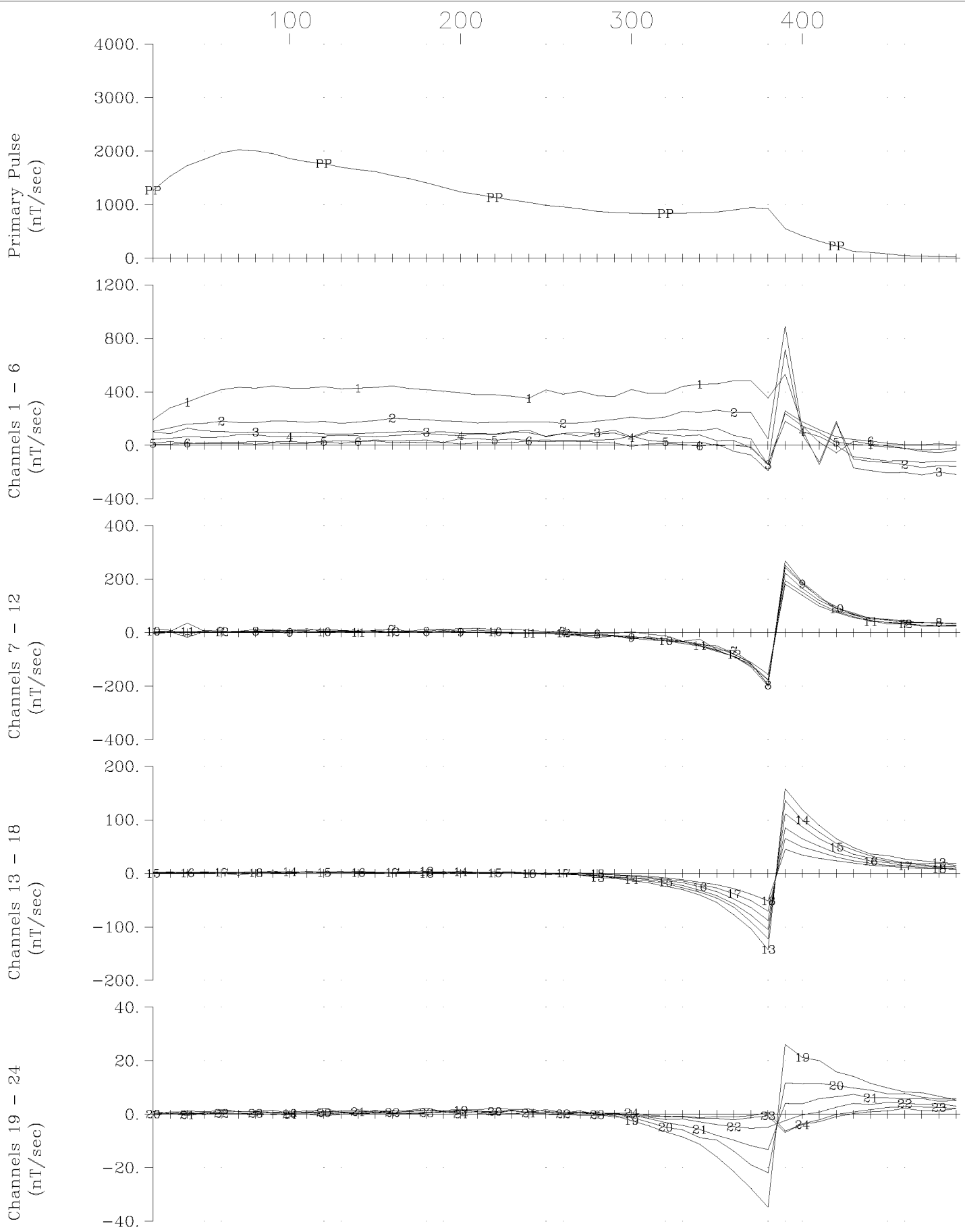

Ursa Major Minerals Inc. Shakespeare East Property
 Loop 2, Hole U-03-121 Y Component
 Crone Geophysics & Exploration Ltd.

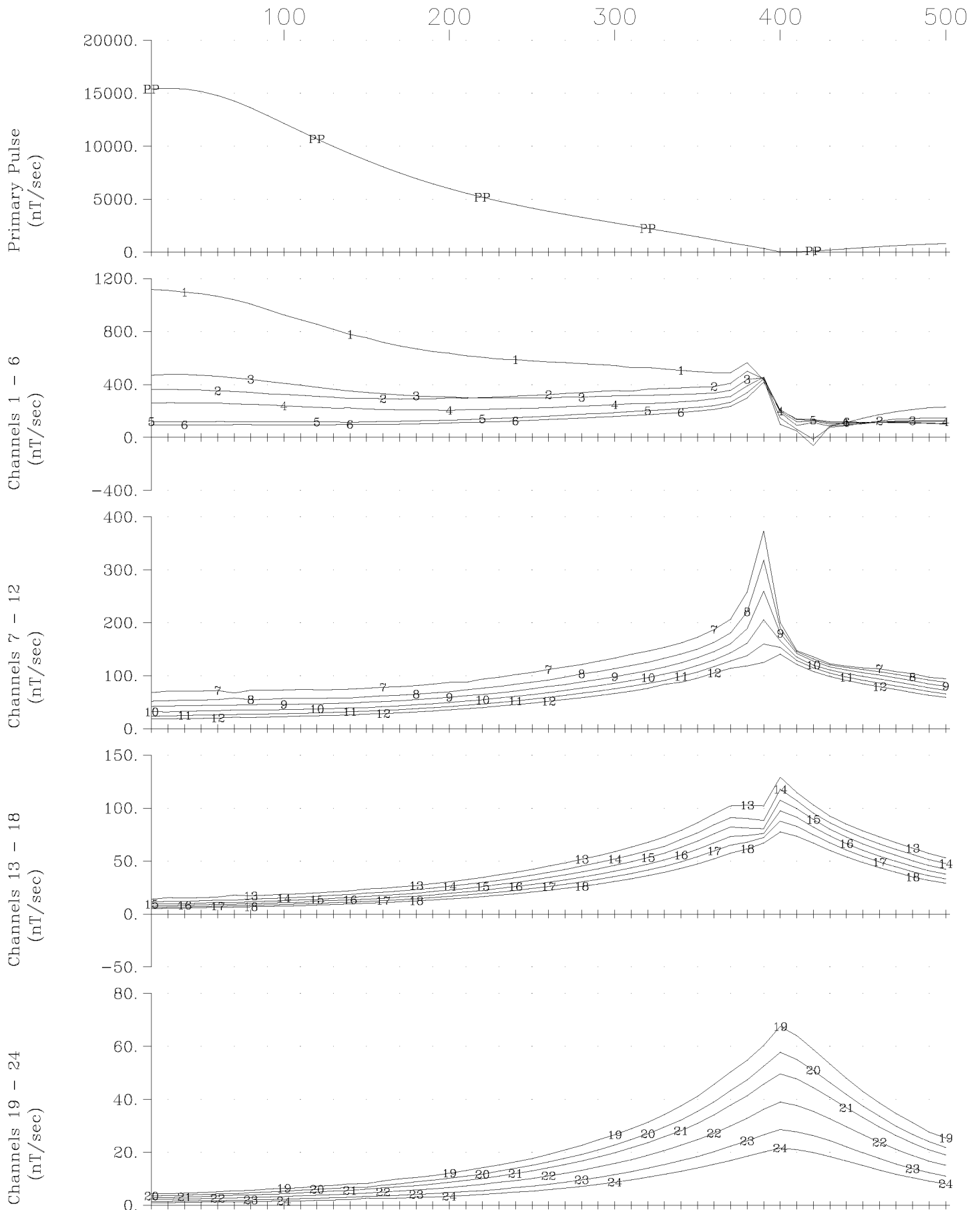

Ursa Major Minerals Inc. Shakespeare East Property
 Loop 2, Hole U-03-121 Z Component
 Crone Geophysics & Exploration Ltd.

APPENDIX III

PULSE EM DATA PROFILES (LIN-LOG SCALE)



Primary Pulse and 20 Off-time Channels
(nT/sec)

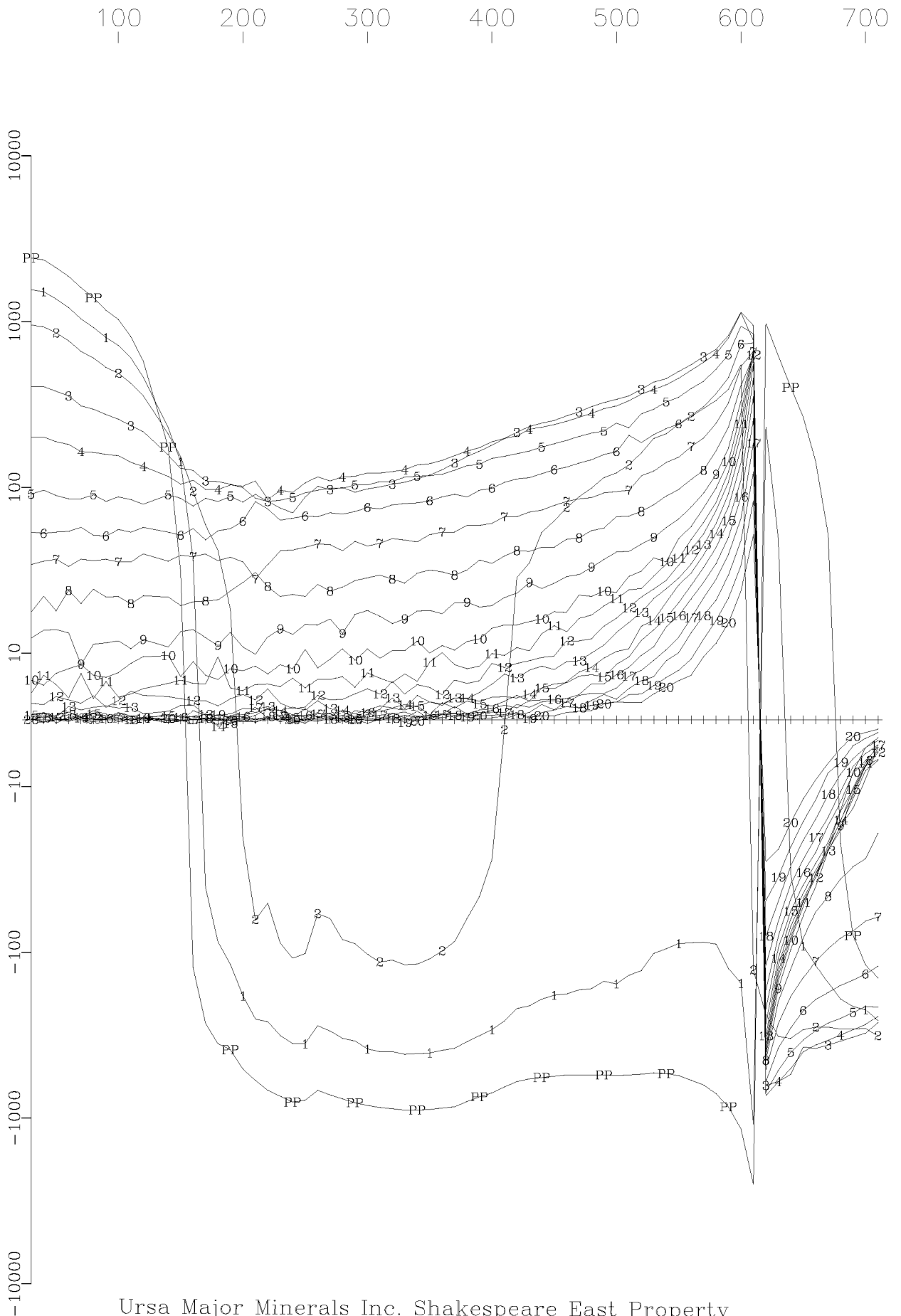

Ursa Major Minerals Inc. Shakespeare East Property
Loop 1, Hole U-08-02 X Component
Crone Geophysics & Exploration Ltd.

Primary Pulse and 20 Off-time Channels
(nT/sec)

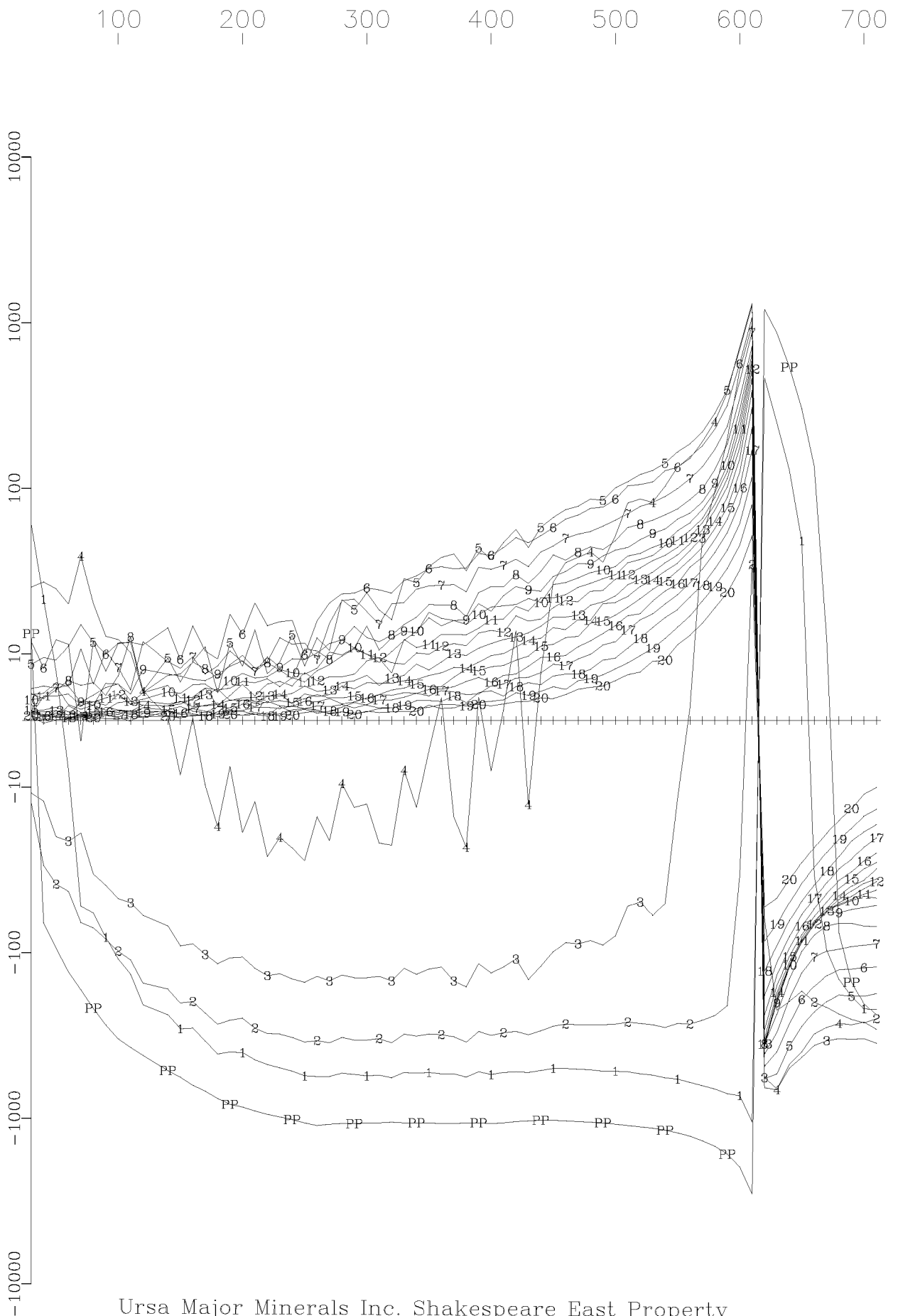

Ursa Major Minerals Inc. Shakespeare East Property
Loop 1, Hole U-08-02 Y Component
Crone Geophysics & Exploration Ltd.

Primary Pulse and 20 Off-time Channels
(nT/sec)

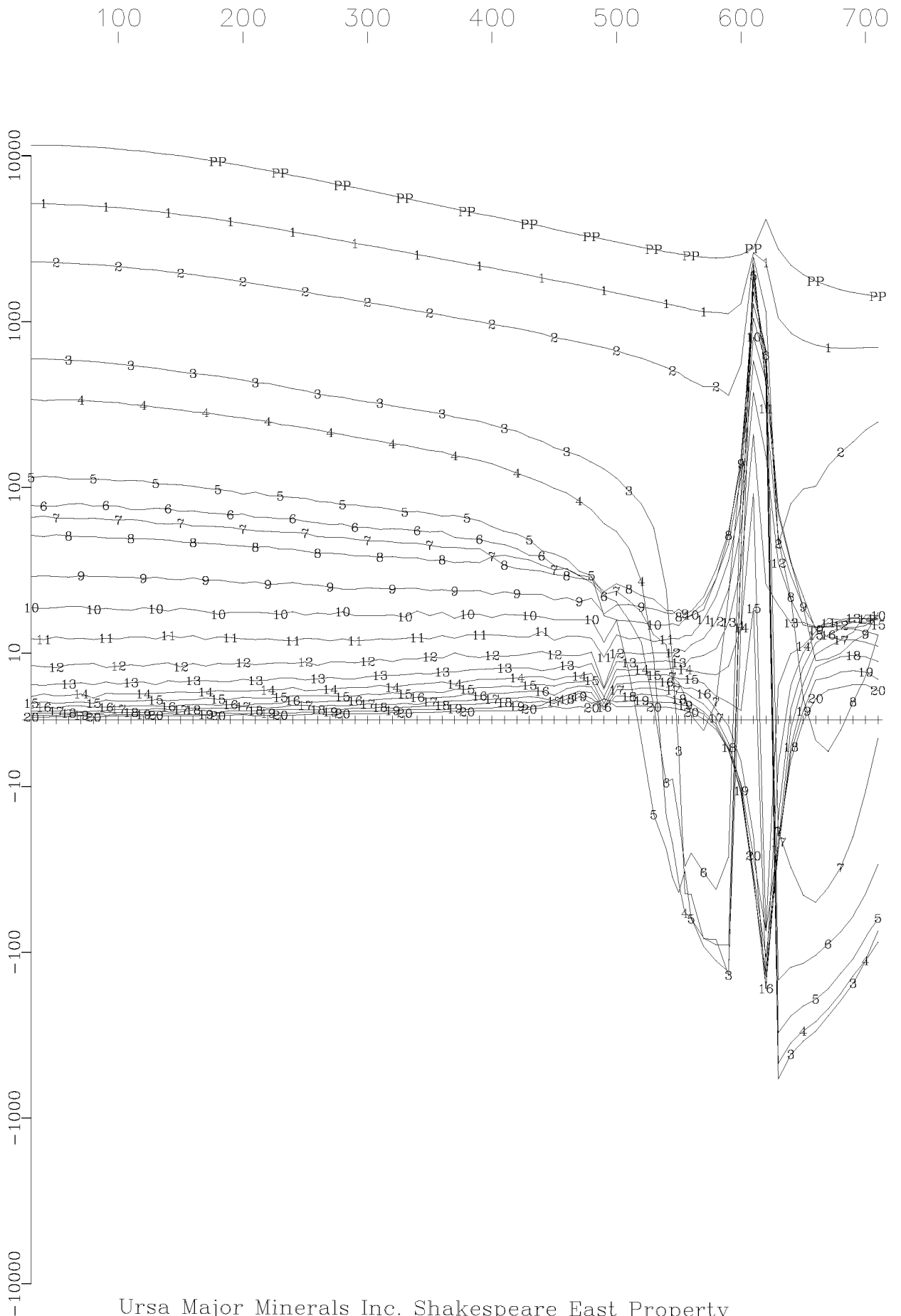

Ursa Major Minerals Inc. Shakespeare East Property
Loop 1, Hole U-08-02 Z Component
Crone Geophysics & Exploration Ltd.

Primary Pulse and 24 Off-time Channels
(nT/sec)

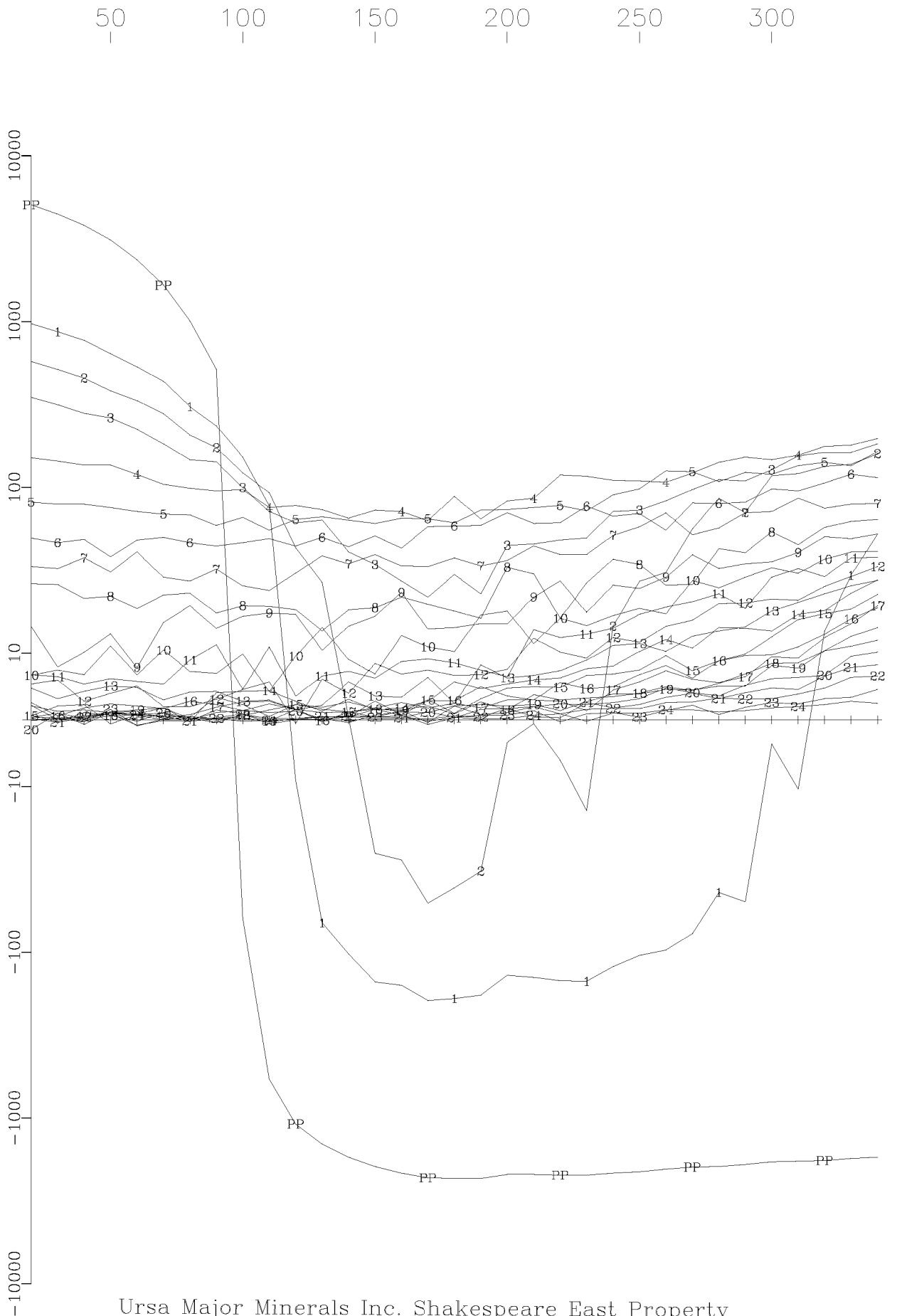

Ursa Major Minerals Inc. Shakespeare East Property
Loop 1, Hole U-03-113 X Component
Crone Geophysics & Exploration Ltd.

Primary Pulse and 24 Off-time Channels
(nT/sec)

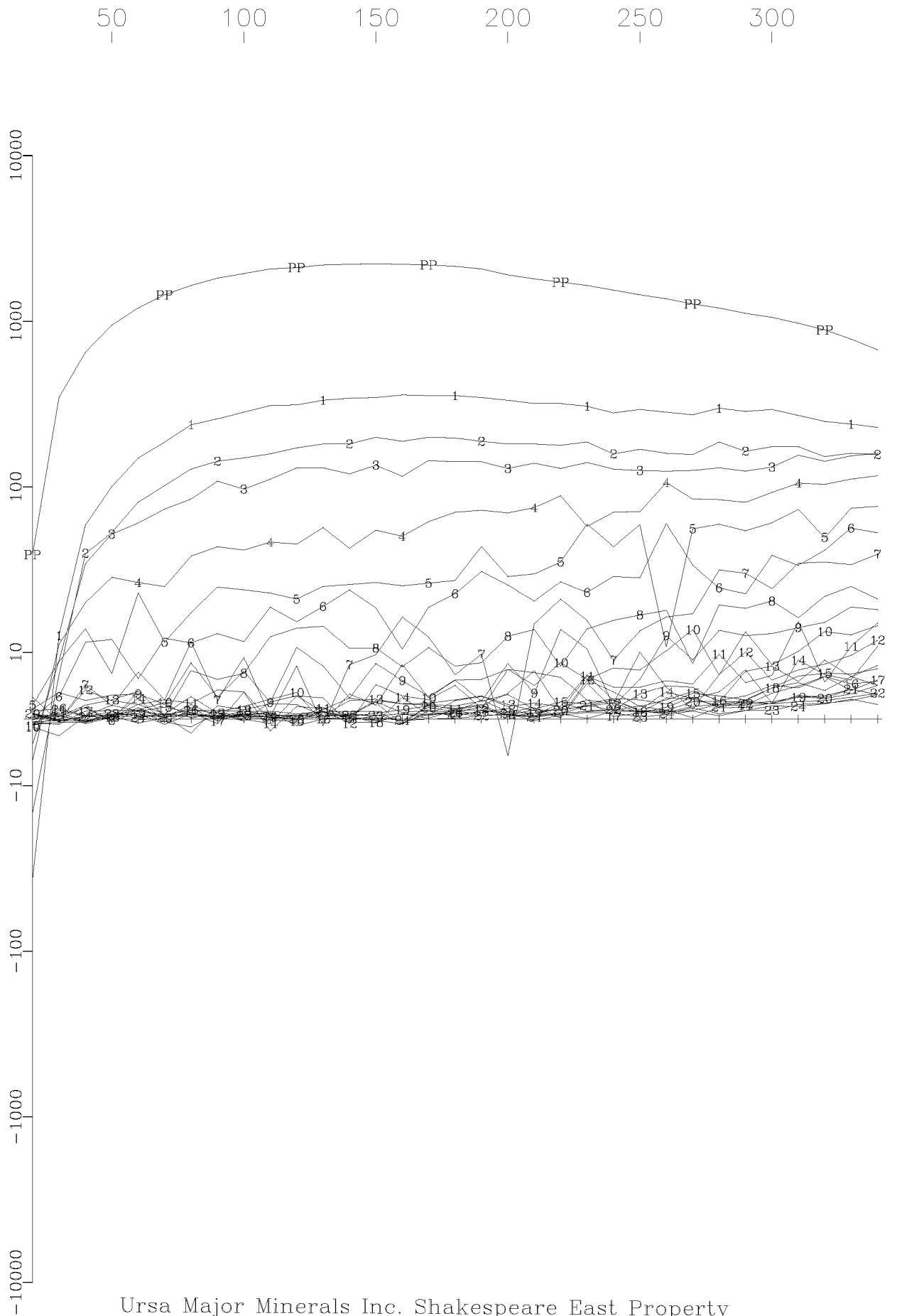

Ursa Major Minerals Inc. Shakespeare East Property
Loop 1, Hole U-03-113 Y Component
Crone Geophysics & Exploration Ltd.

Primary Pulse and 24 Off-time Channels
(nT/sec)

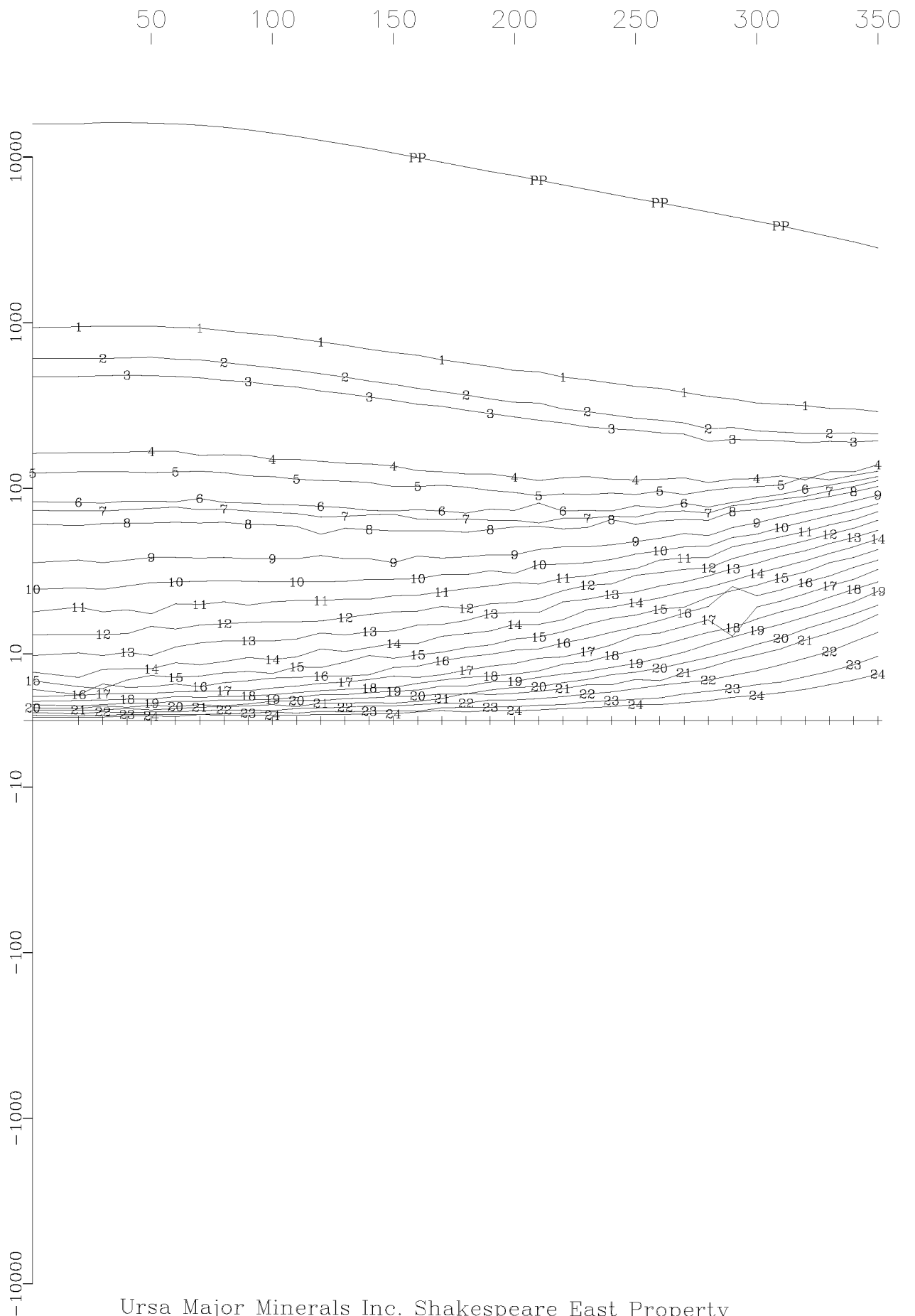

Ursa Major Minerals Inc. Shakespeare East Property
Loop 1, Hole U-03-113 Z Component
Crone Geophysics & Exploration Ltd.

Primary Pulse and 24 Off-time Channels
(nT/sec)

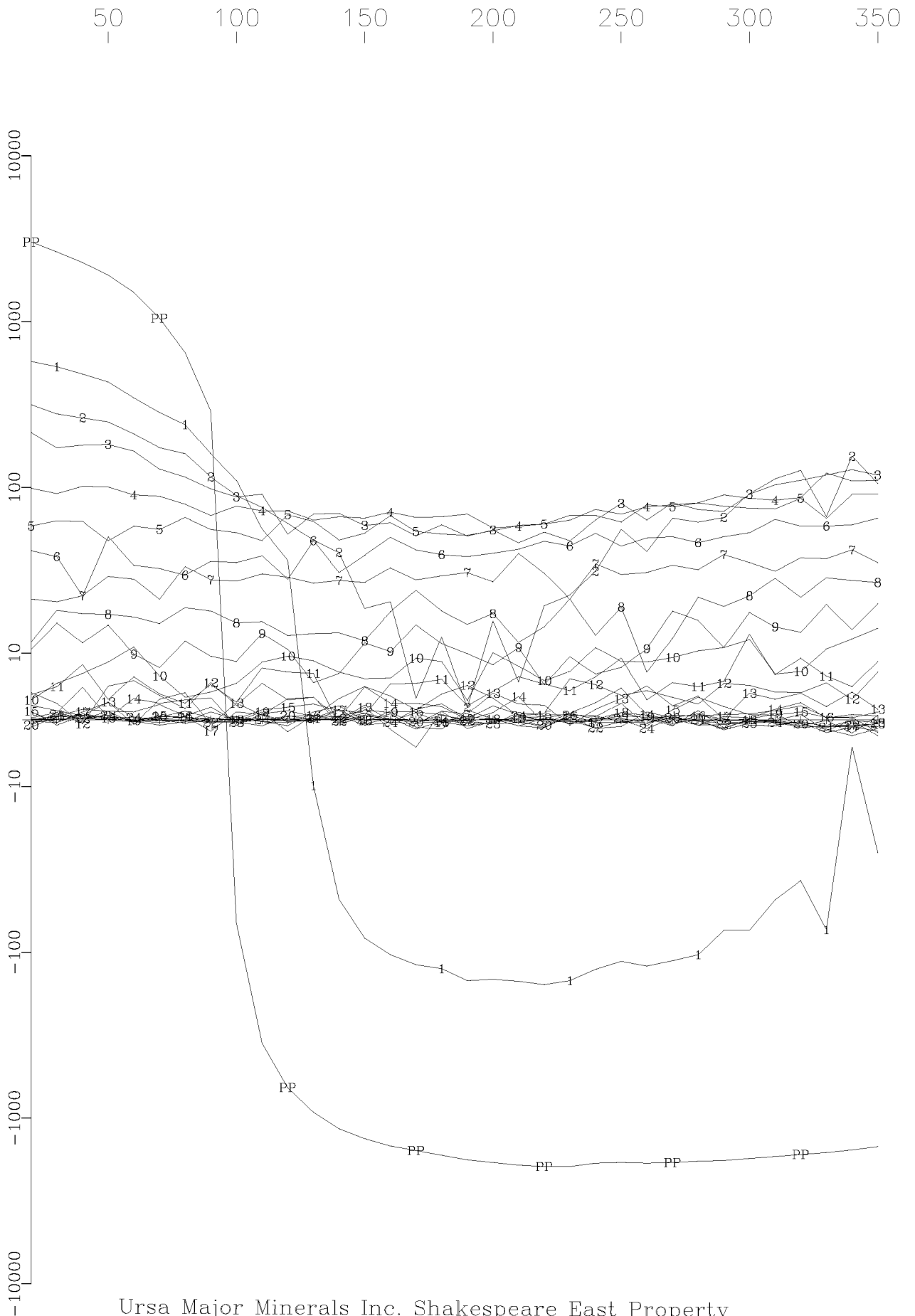

Ursa Major Minerals Inc. Shakespeare East Property
Loop 1, Hole U-03-114 X Component
Crone Geophysics & Exploration Ltd.

Primary Pulse and 24 Off-time Channels
(nT/sec)

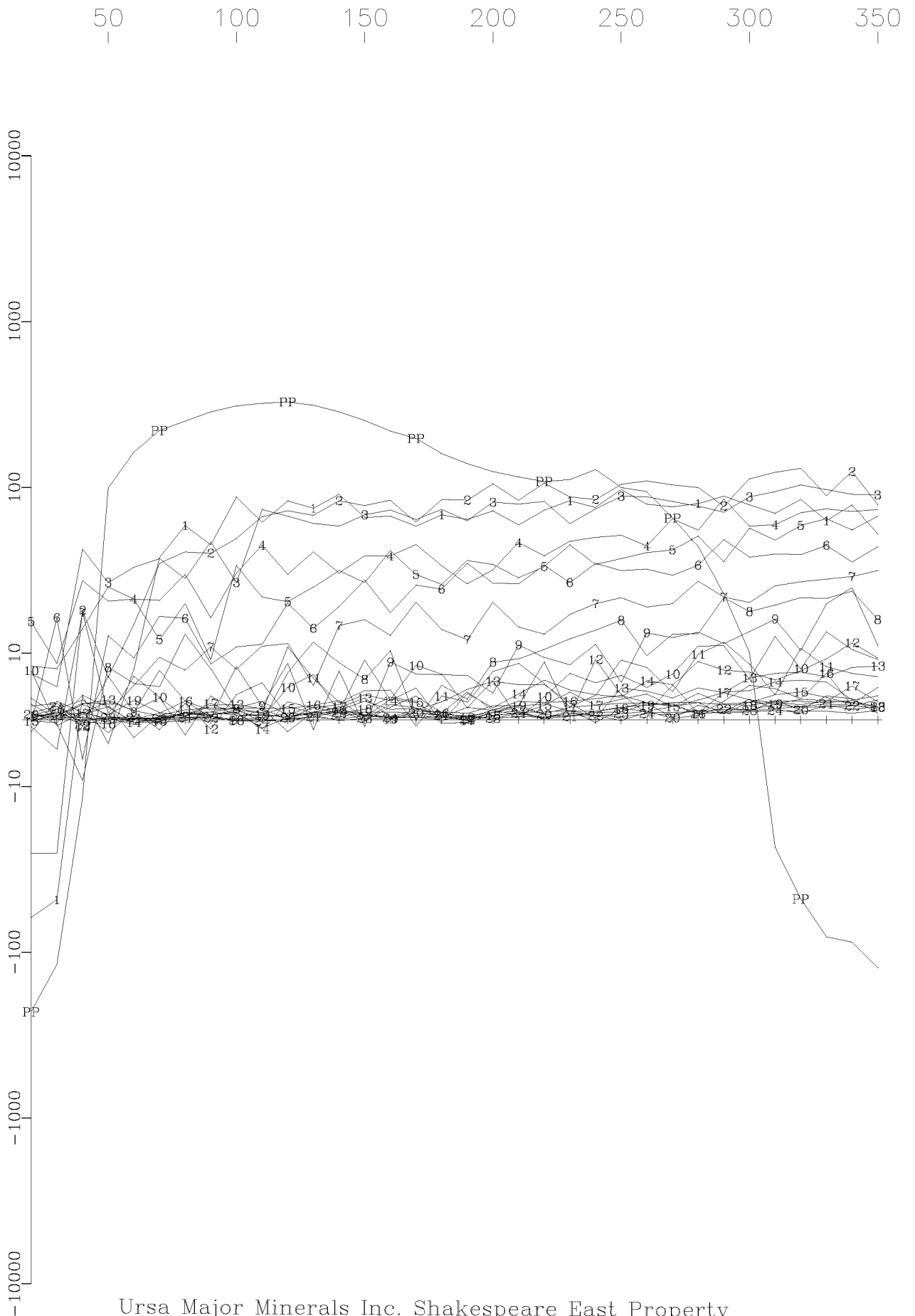

Ursa Major Minerals Inc. Shakespeare East Property
Loop 1, Hole U-03-114 Y Component
Crone Geophysics & Exploration Ltd.

Primary Pulse and 24 Off-time Channels
(nT/sec)

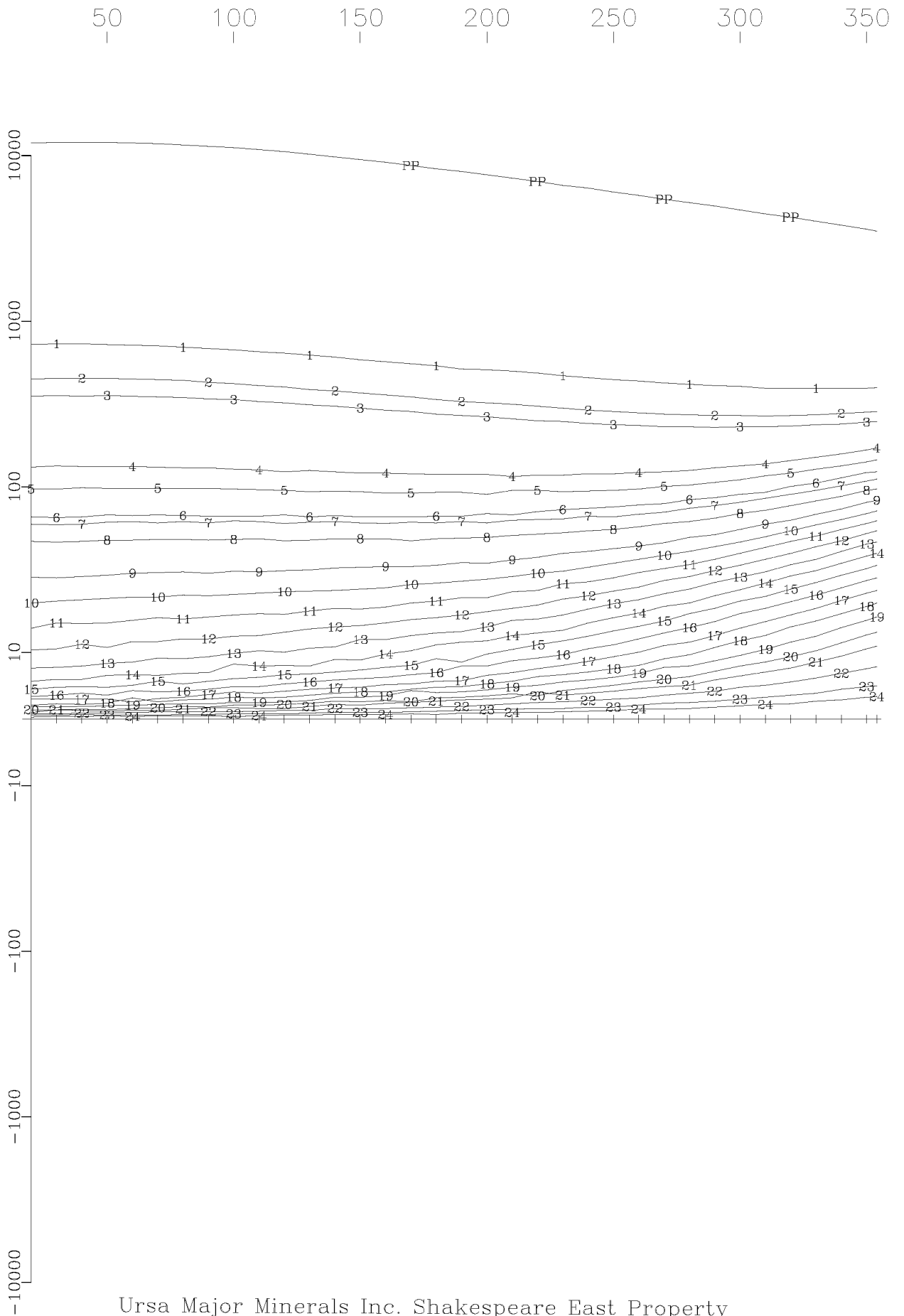

Ursa Major Minerals Inc. Shakespeare East Property
Loop 1, Hole U-03-114 Z Component
Crone Geophysics & Exploration Ltd.

Primary Pulse and 24 Off-time Channels
(nT/sec)

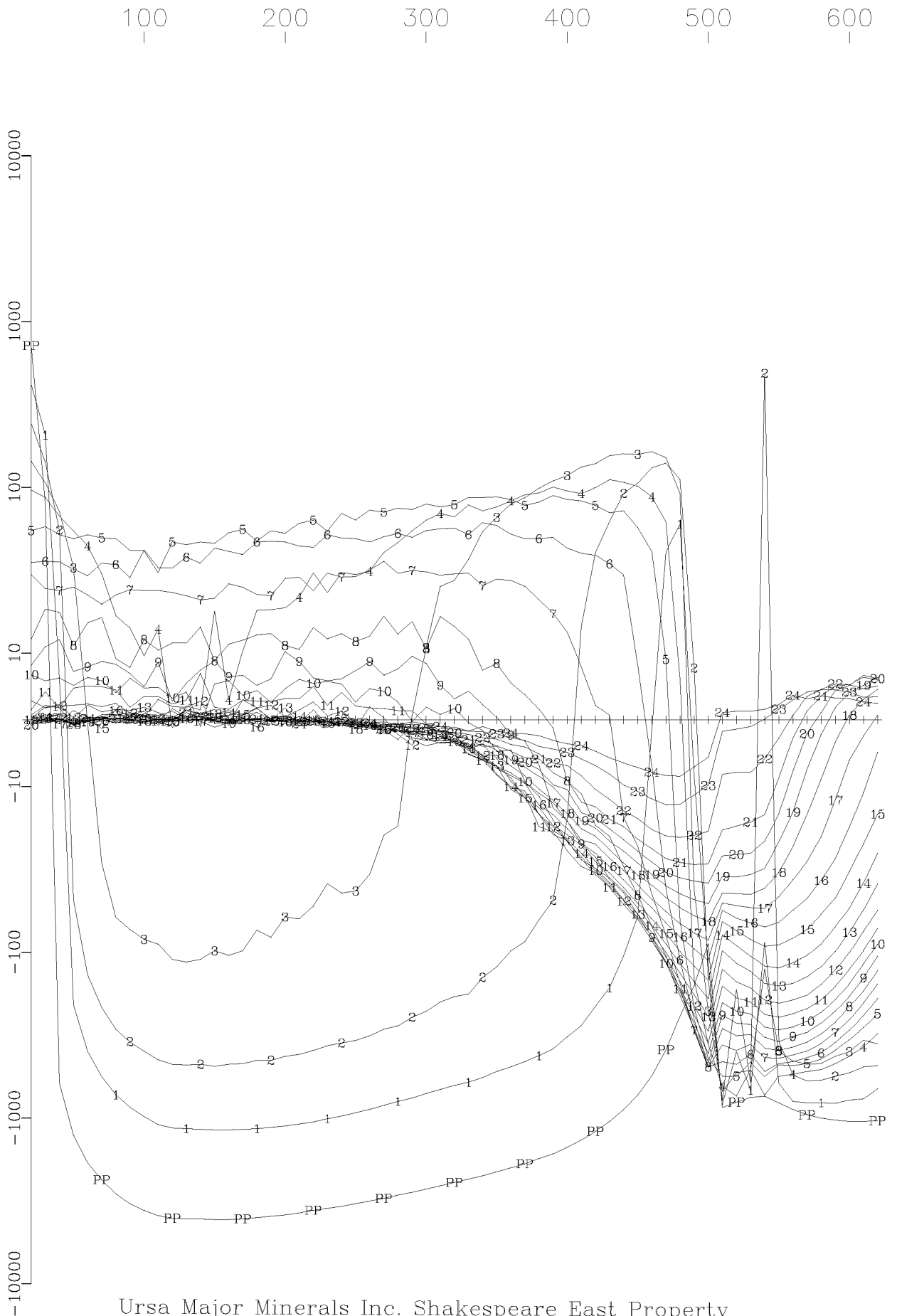

Ursa Major Minerals Inc. Shakespeare East Property
Loop 1, Hole U-03-116 X Component
Crone Geophysics & Exploration Ltd.

Primary Pulse and 24 Off-time Channels
(nT/sec)

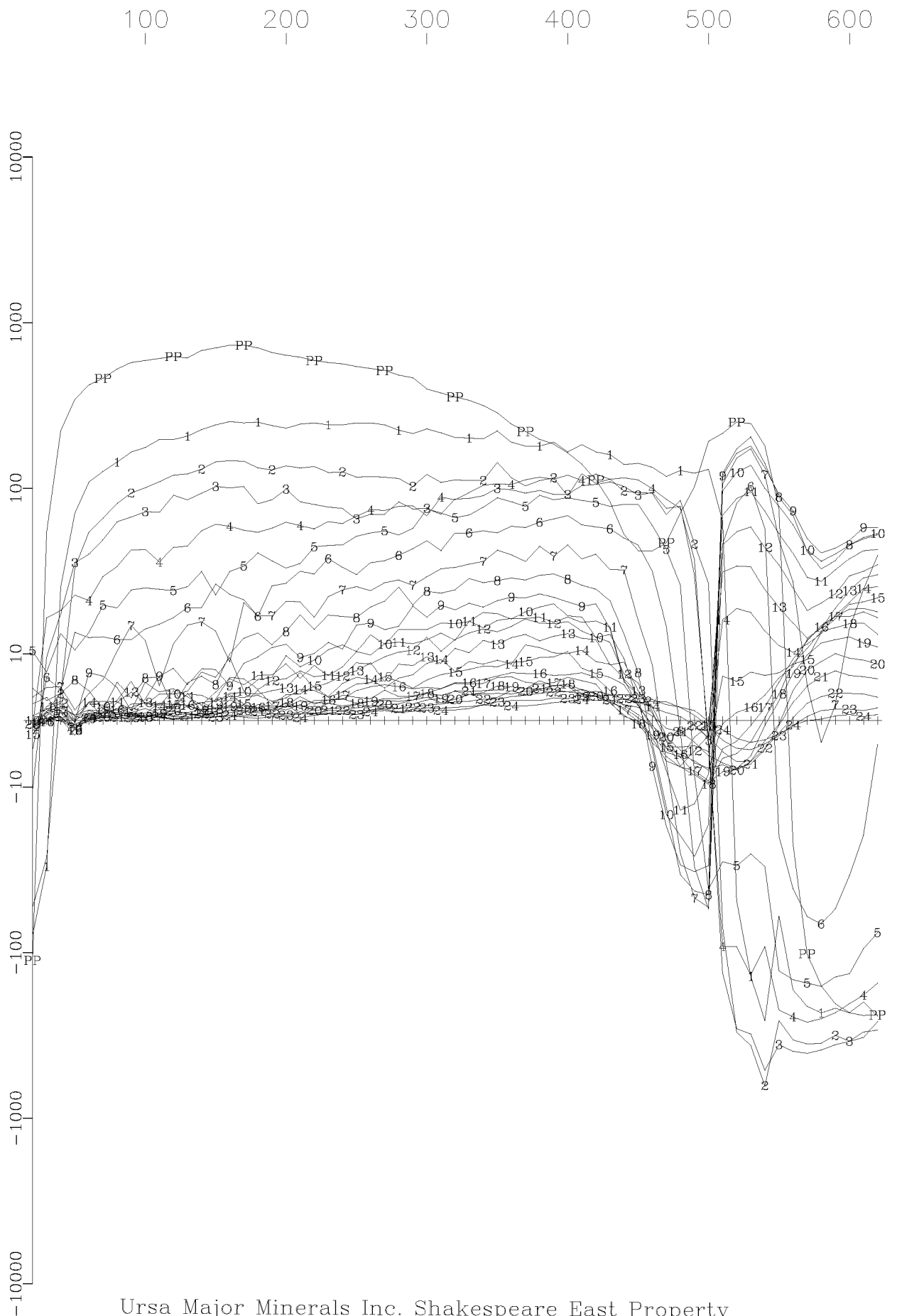

Ursa Major Minerals Inc. Shakespeare East Property
Loop 1, Hole U-03-116 Y Component
Crone Geophysics & Exploration Ltd.

Primary Pulse and 24 Off-time Channels
(nT/sec)

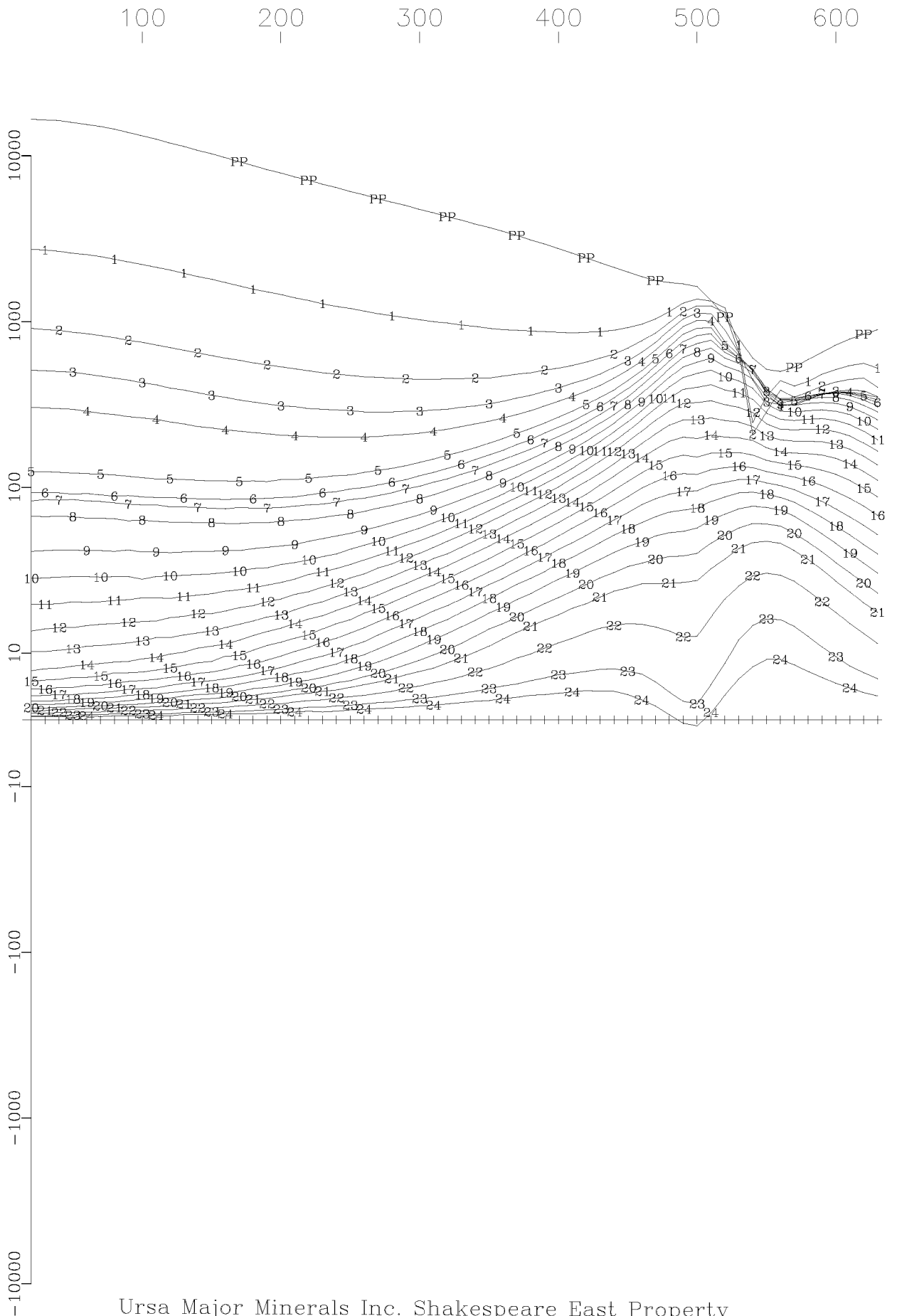

Ursa Major Minerals Inc. Shakespeare East Property
Loop 1, Hole U-03-116 Z Component
Crone Geophysics & Exploration Ltd.

Primary Pulse and 20 Off-time Channels
(nT/sec)

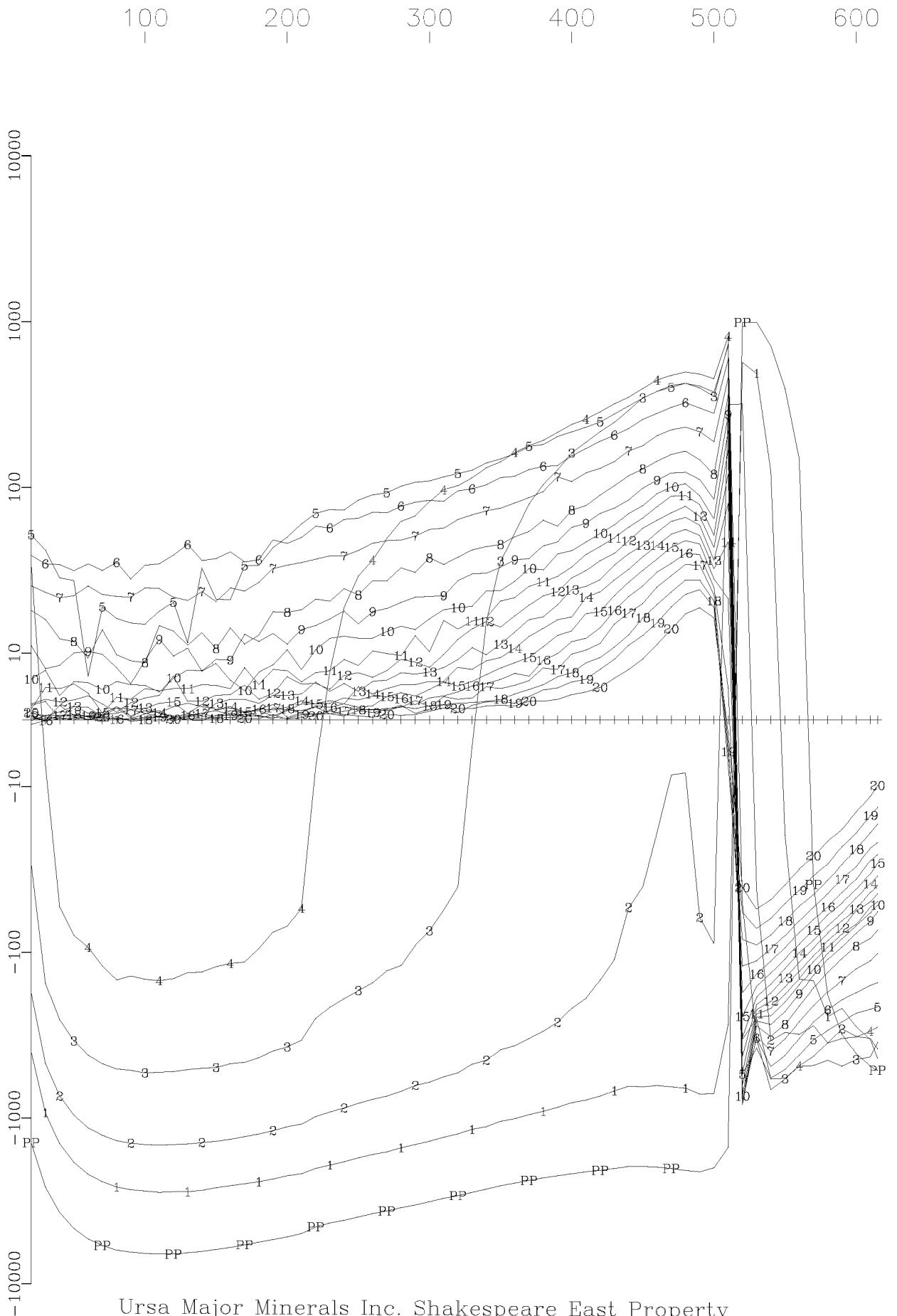

Ursa Major Minerals Inc. Shakespeare East Property
Loop 1, Hole U-03-118 X Component
Crone Geophysics & Exploration Ltd.

Primary Pulse and 20 Off-time Channels
(nT/sec)

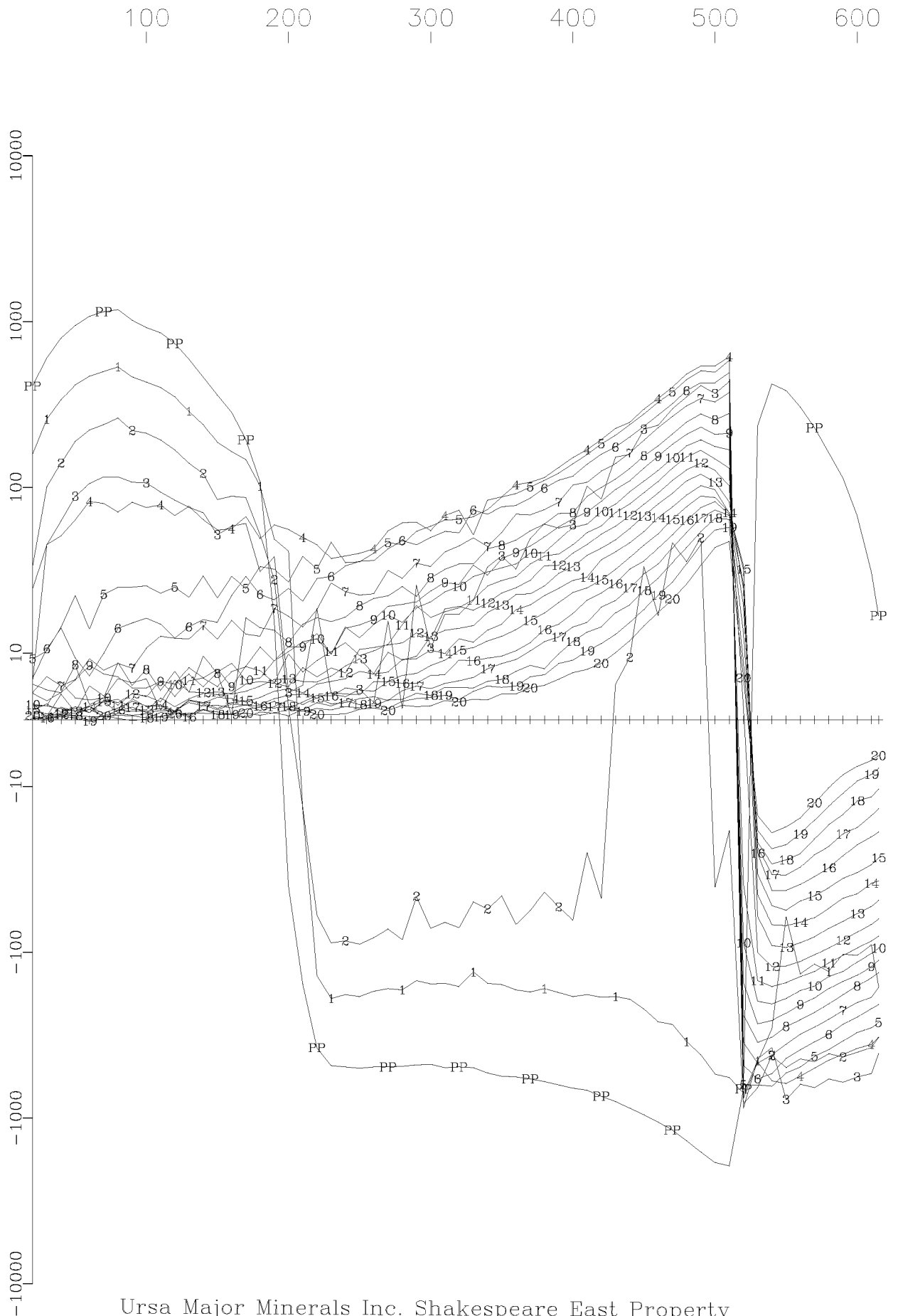

Ursa Major Minerals Inc. Shakespeare East Property
Loop 1, Hole U-03-118 Y Component
Crone Geophysics & Exploration Ltd.

Primary Pulse and 20 Off-time Channels
(nT/sec)

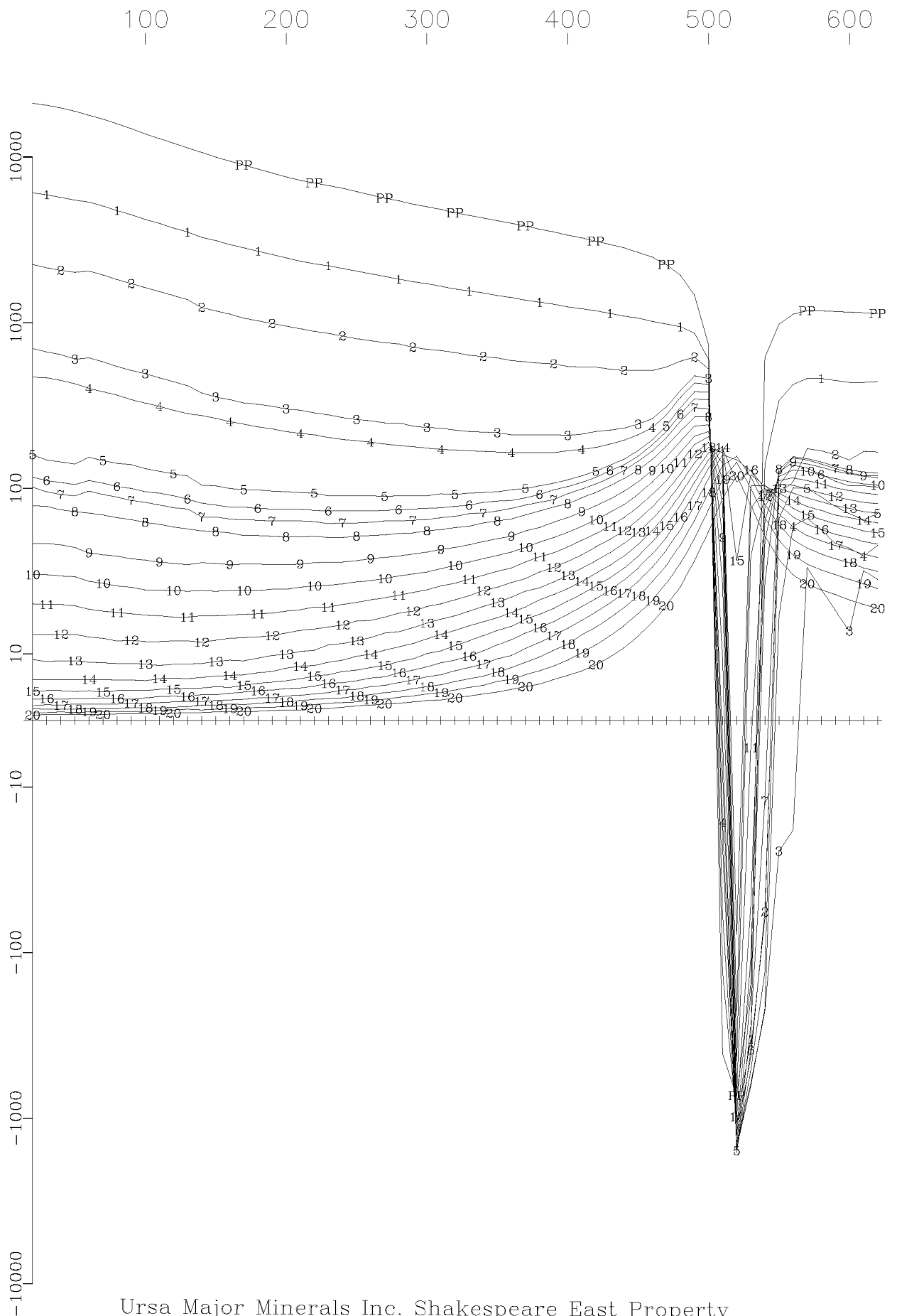

Ursa Major Minerals Inc. Shakespeare East Property
Loop 1, Hole U-03-118 Z Component
Crone Geophysics & Exploration Ltd.

Primary Pulse and 24 Off-time Channels
(nT/sec)

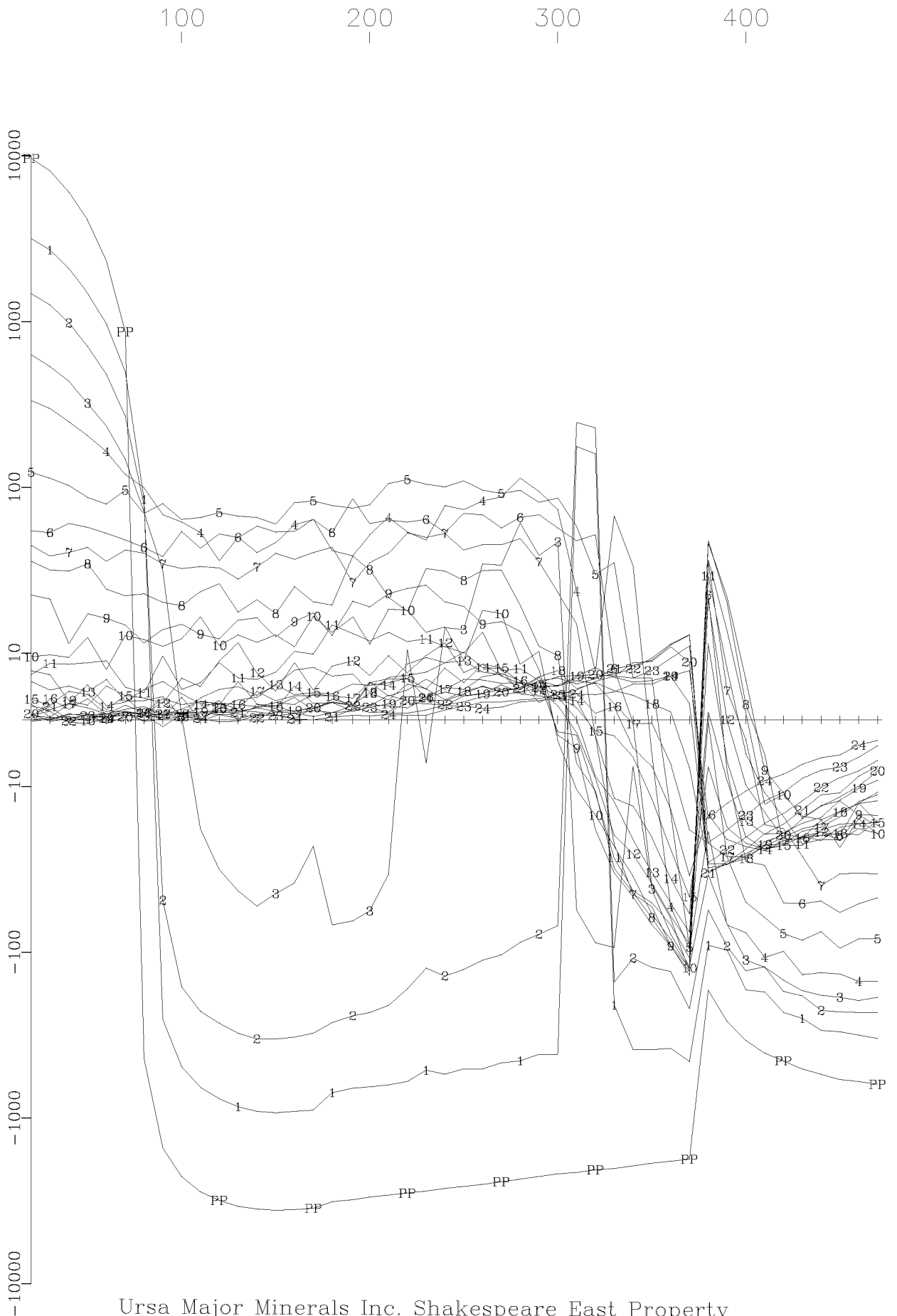

Ursa Major Minerals Inc. Shakespeare East Property
Loop 1, Hole U-03-120 X Component
Crone Geophysics & Exploration Ltd.

Primary Pulse and 24 Off-time Channels
(nT/sec)

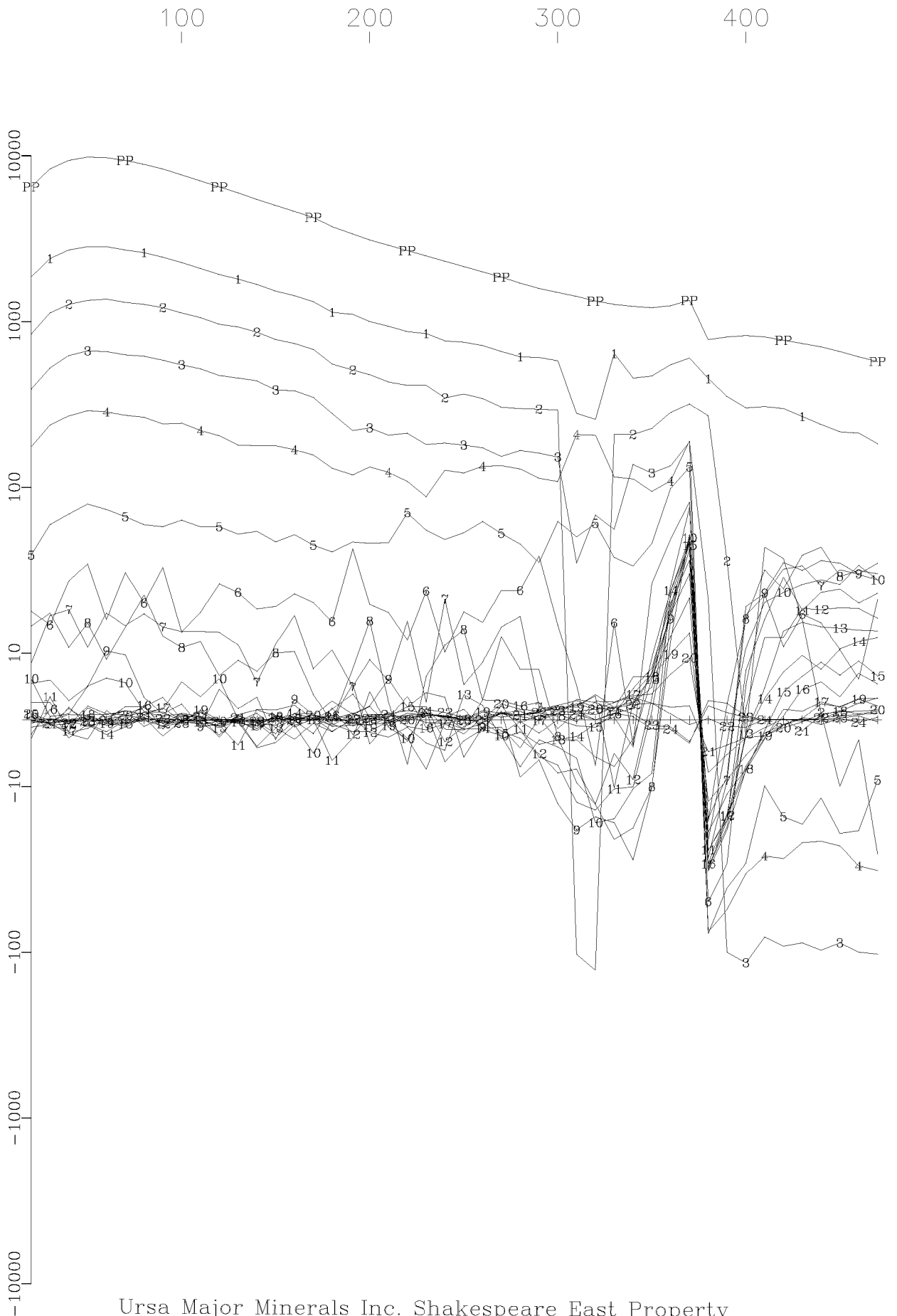

Ursa Major Minerals Inc. Shakespeare East Property
Loop 1, Hole U-03-120 Y Component
Crone Geophysics & Exploration Ltd.

Primary Pulse and 24 Off-time Channels
(nT/sec)

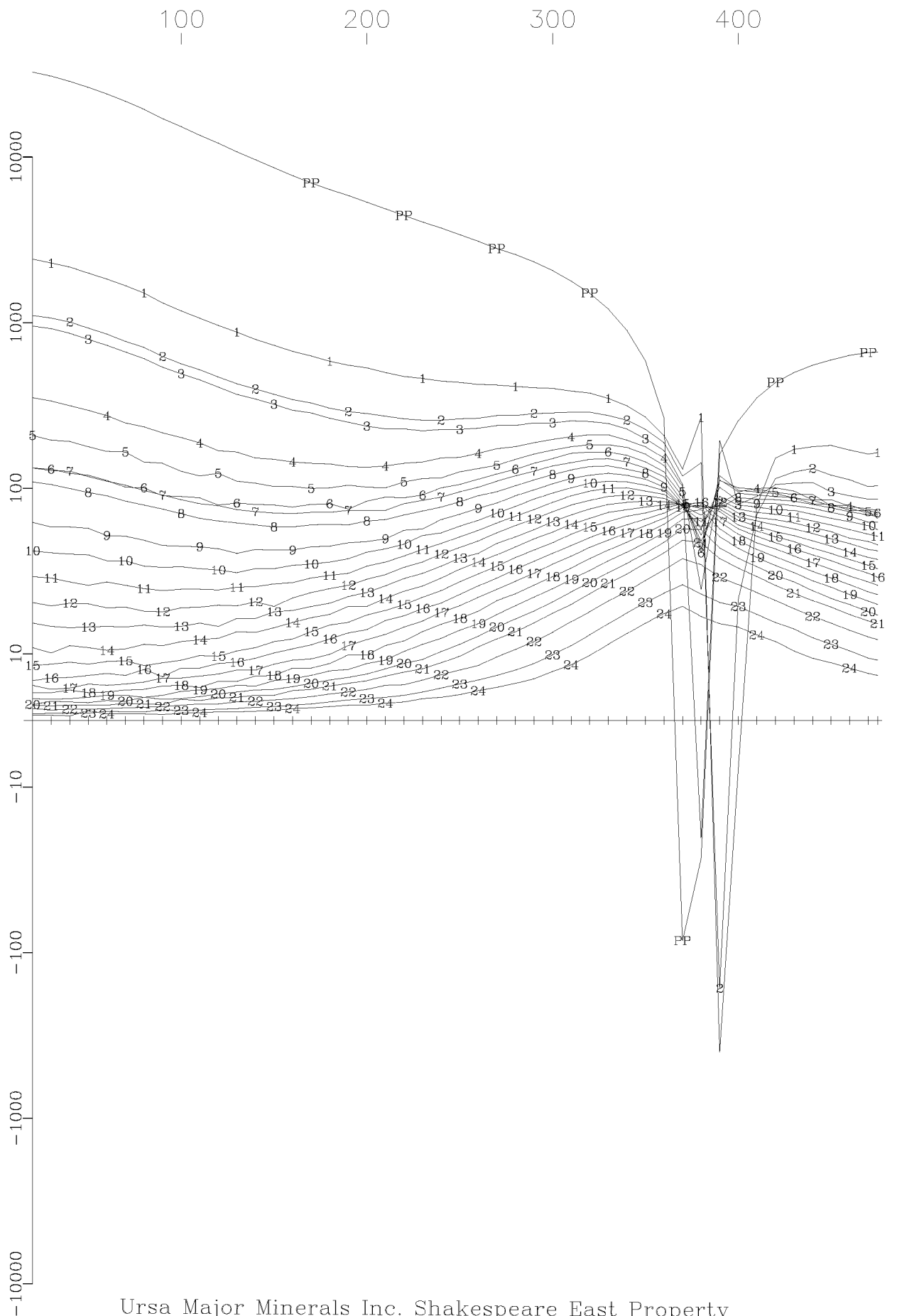

Ursa Major Minerals Inc. Shakespeare East Property
Loop 1, Hole U-03-120 Z Component
Crone Geophysics & Exploration Ltd.

Primary Pulse and 24 Off-time Channels
(nT/sec)

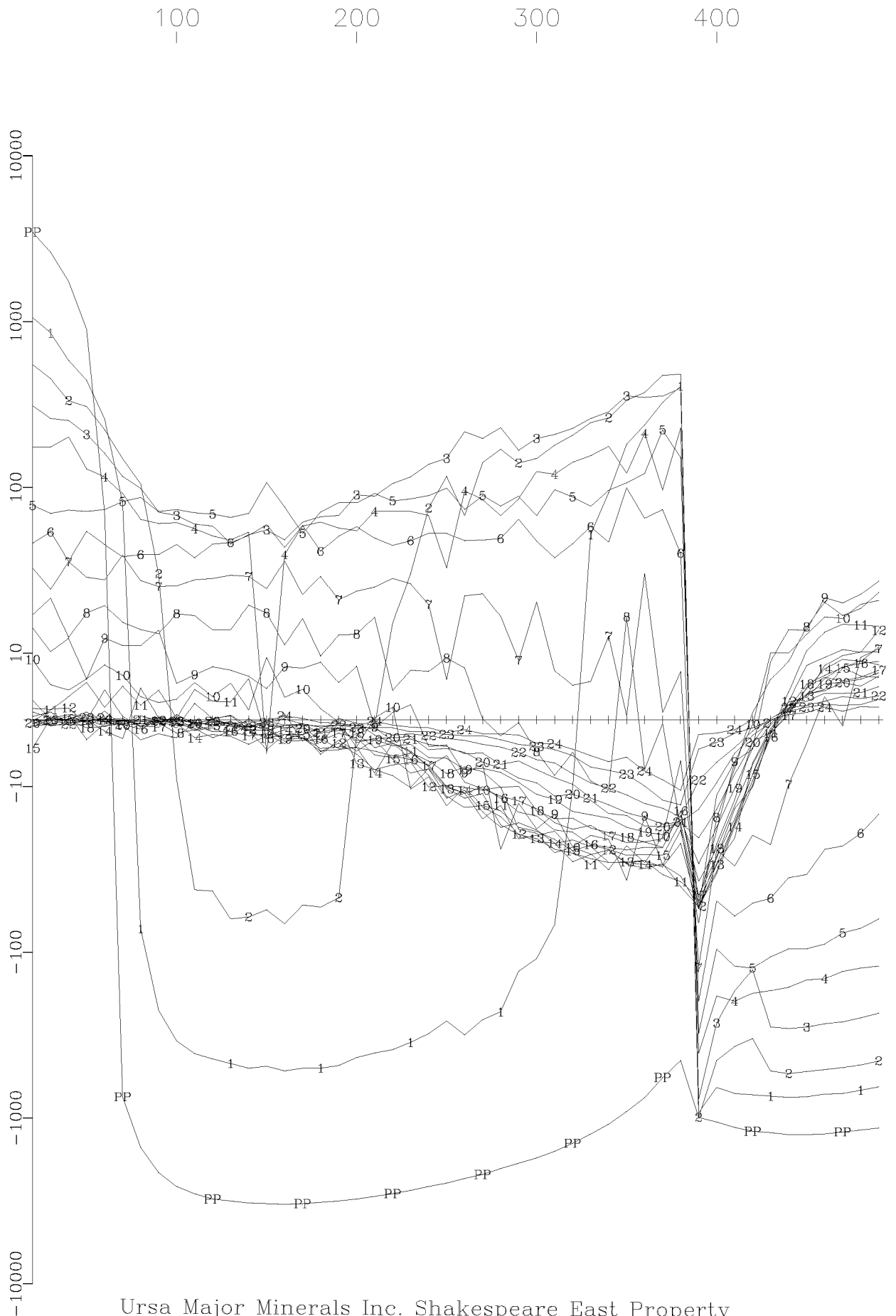

Ursa Major Minerals Inc. Shakespeare East Property
Loop 2, Hole U-03-121 X Component
Crone Geophysics & Exploration Ltd.

Primary Pulse and 24 Off-time Channels
(nT/sec)

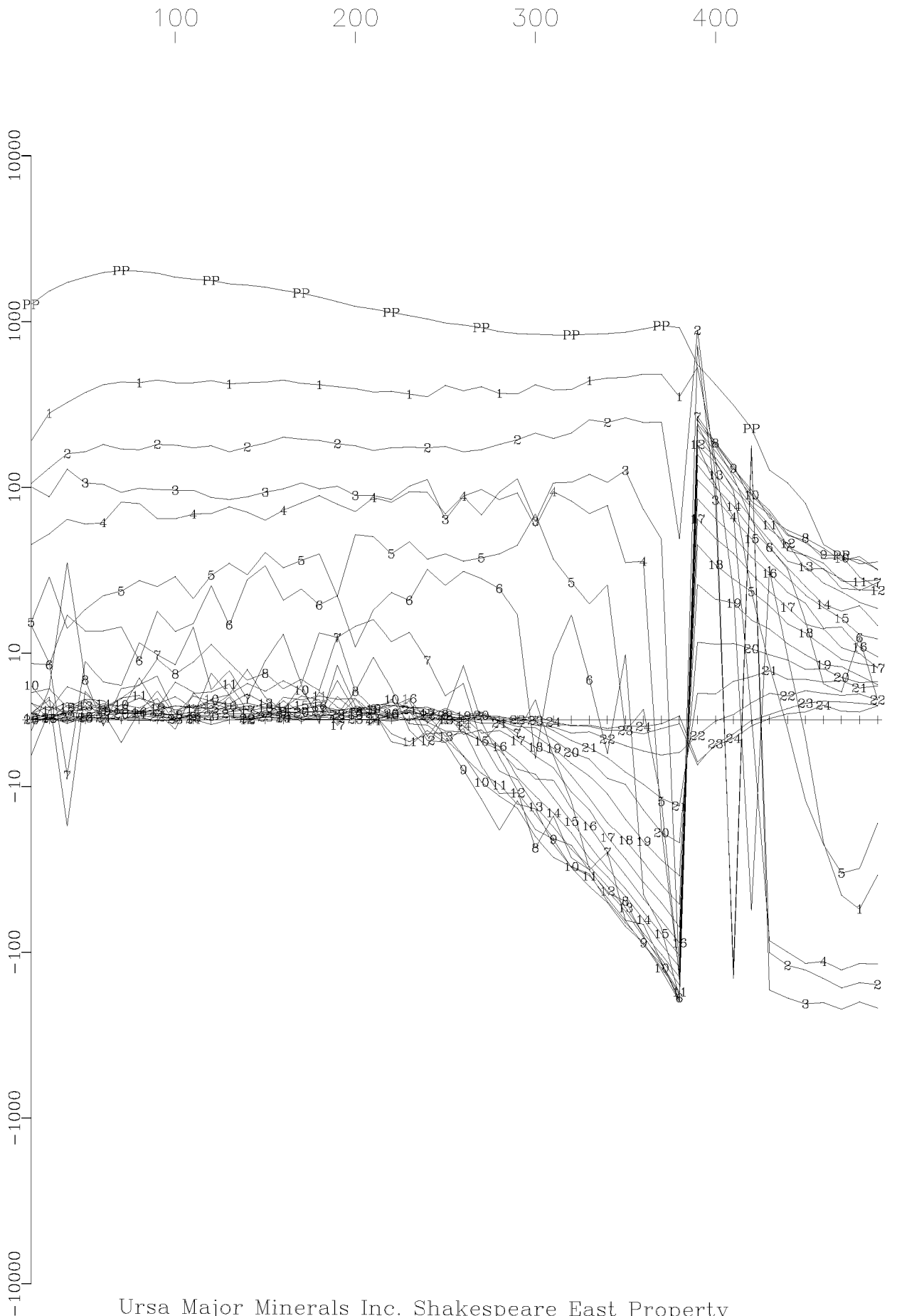

Ursa Major Minerals Inc. Shakespeare East Property
Loop 2, Hole U-03-121 Y Component
Crone Geophysics & Exploration Ltd.

Primary Pulse and 24 Off-time Channels
(nT/sec)

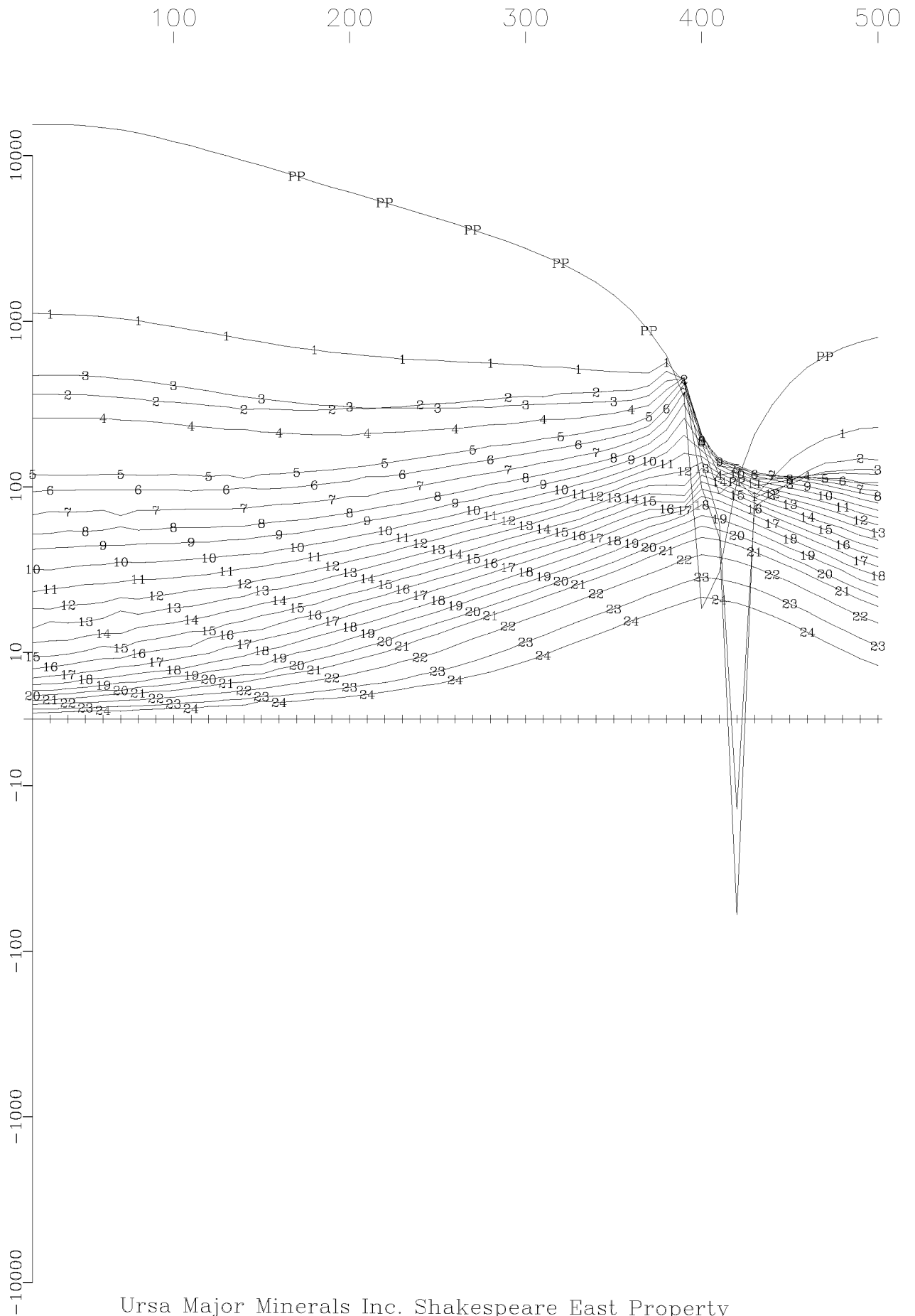

Ursa Major Minerals Inc. Shakespeare East Property
Loop 2, Hole U-03-121 Z Component
Crone Geophysics & Exploration Ltd.

APPENDIX IV
STEP RESPONSE DATA PROFILES



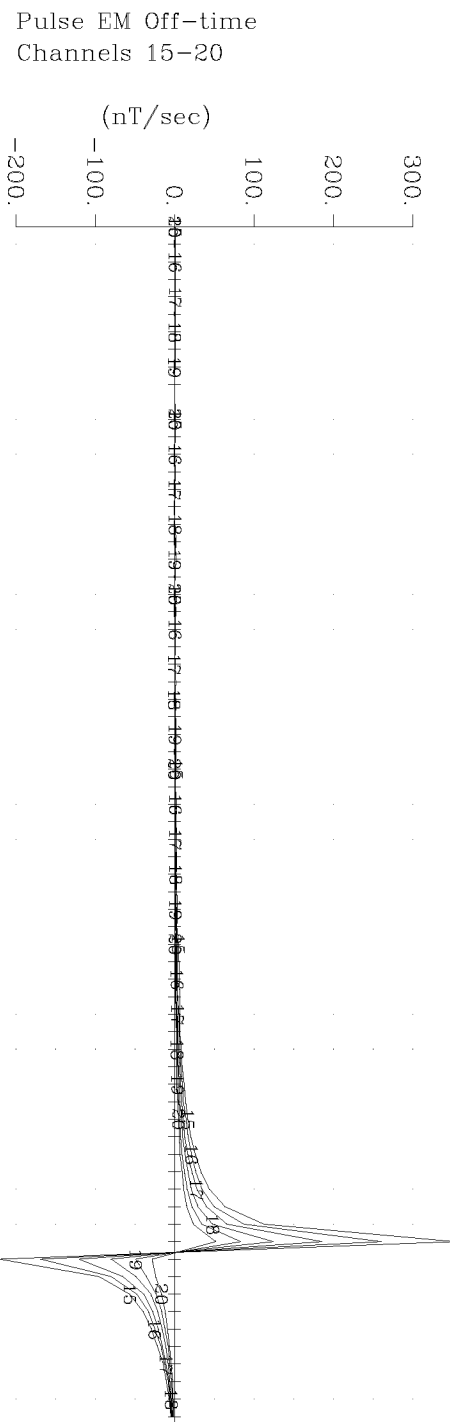
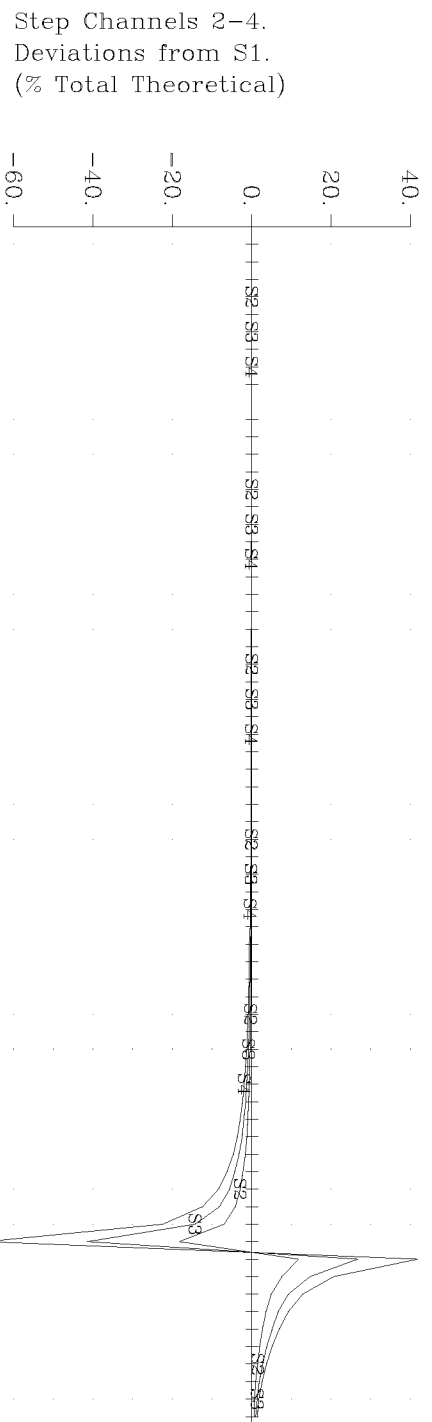
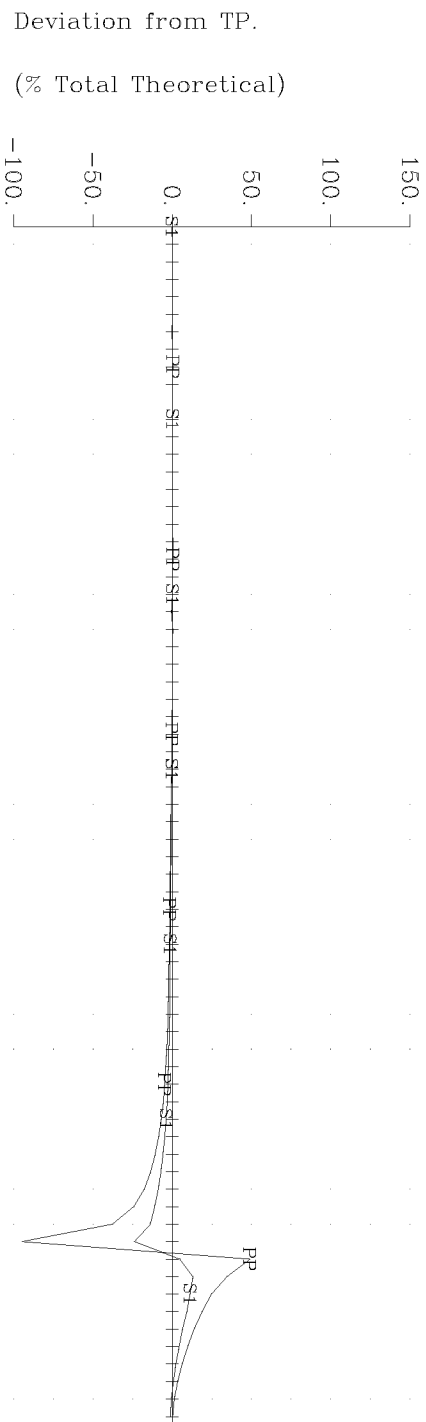
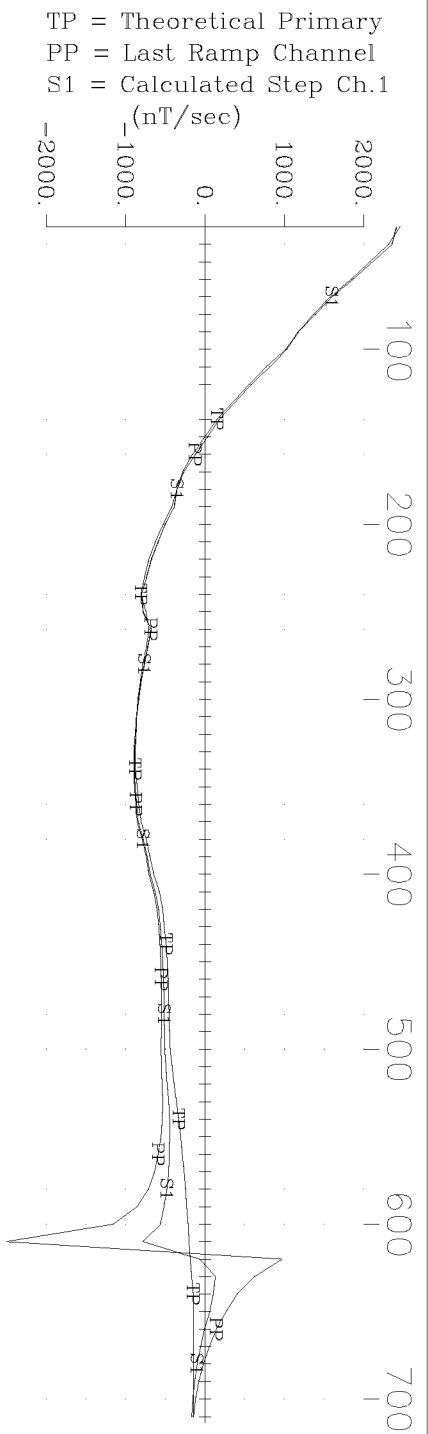

Ursa Major Minerals Inc. Shakespeare East Property
 Loop 1, Hole U-08-02 X Component
 Crone Geophysics & Exploration Ltd.

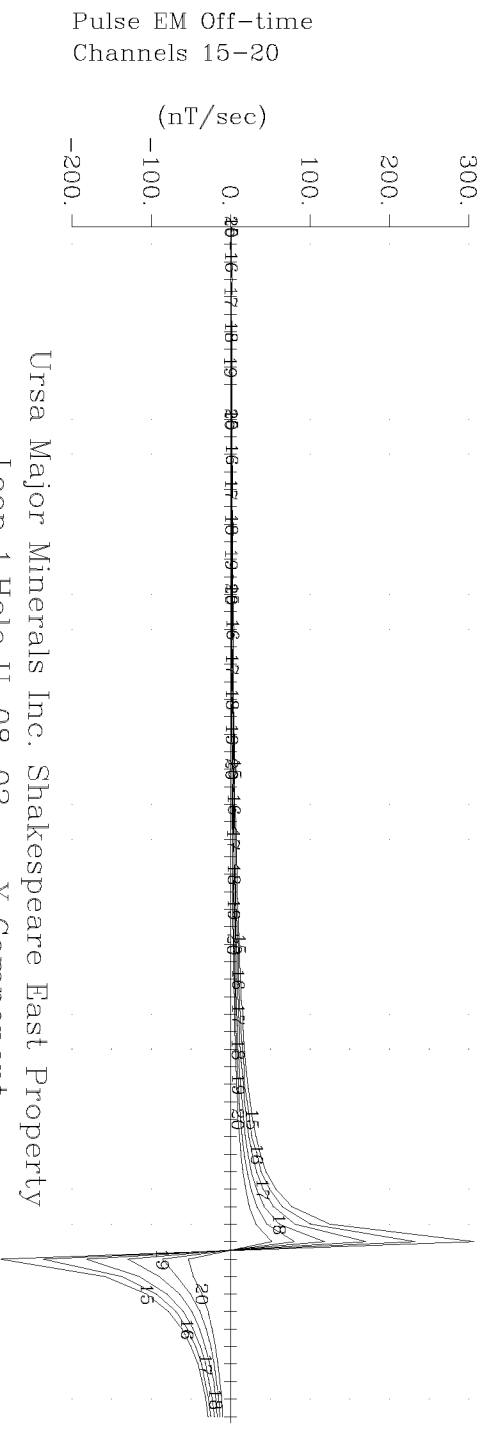
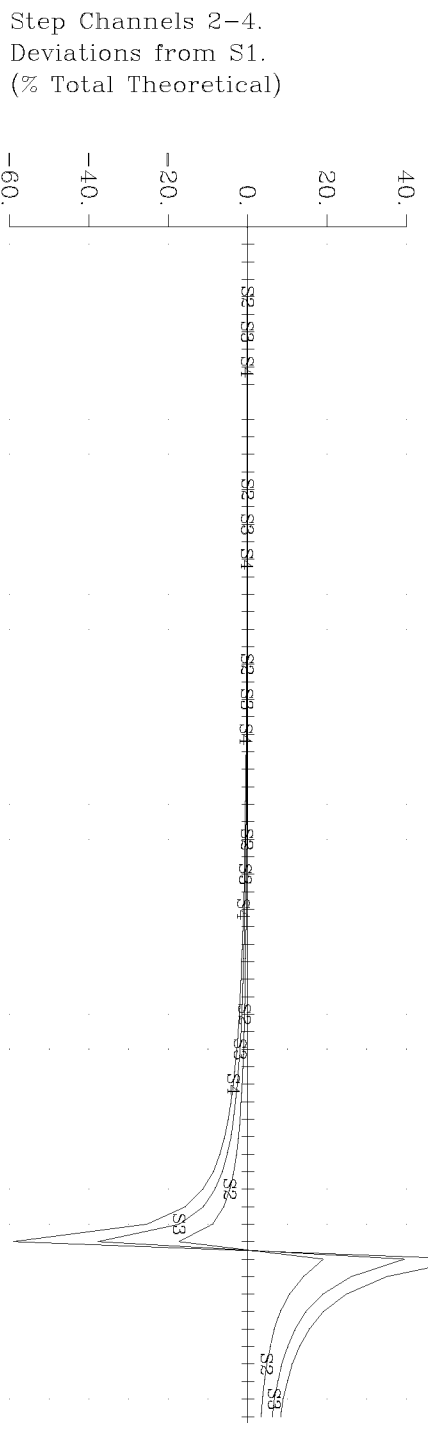
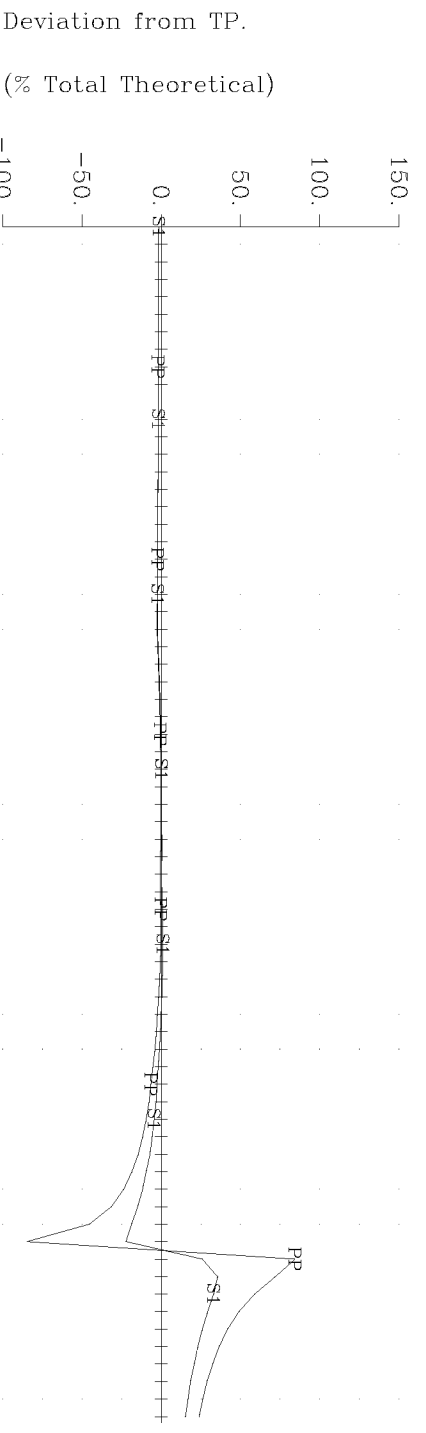
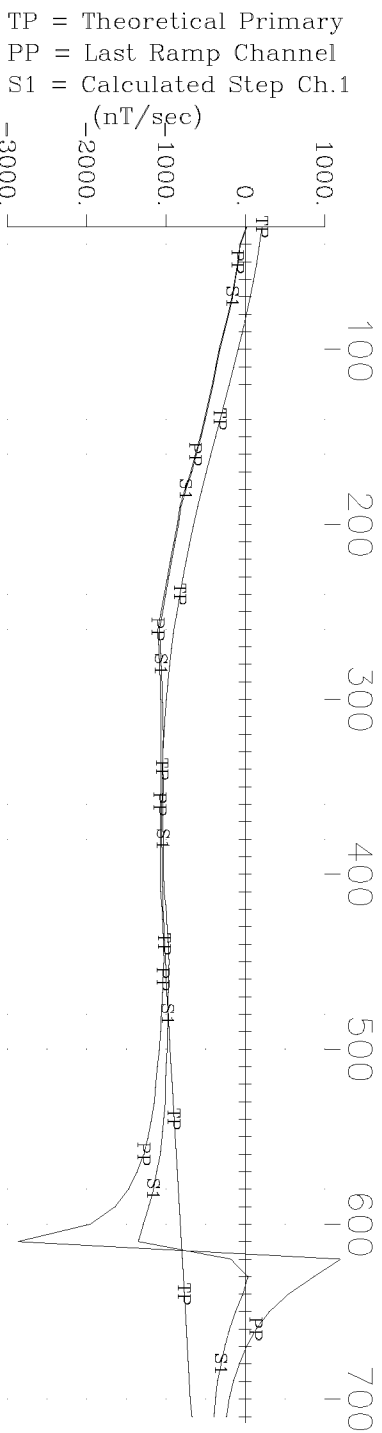

Ursa Major Minerals Inc. Shakespeare East Property
 Loop 1, Hole U-08-02 Y Component
 Crone Geophysics & Exploration Ltd.

TP = Theoretical Primary
 PP = Last Ramp Channel
 S1 = Calculated Step Ch.1

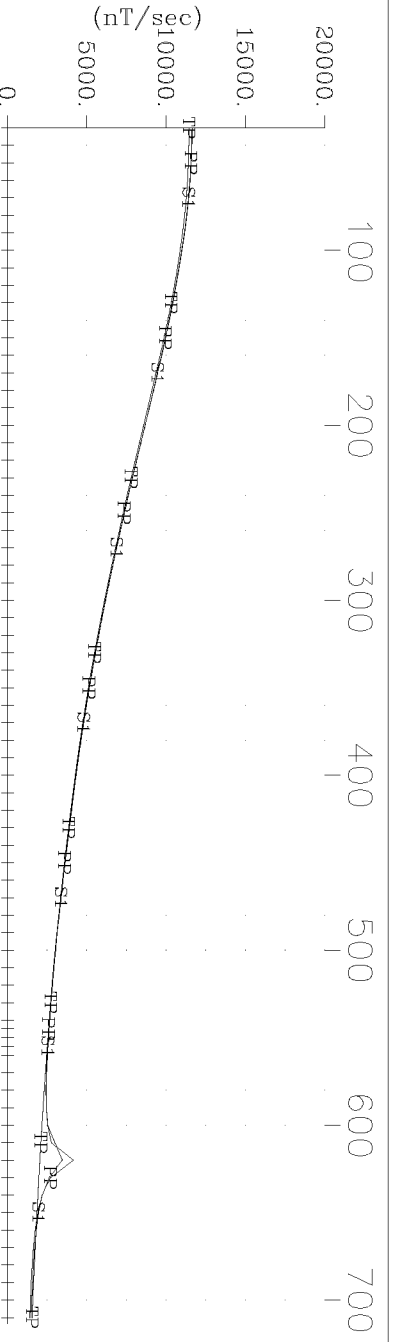

Deviation from TP.
 (% Total Theoretical)

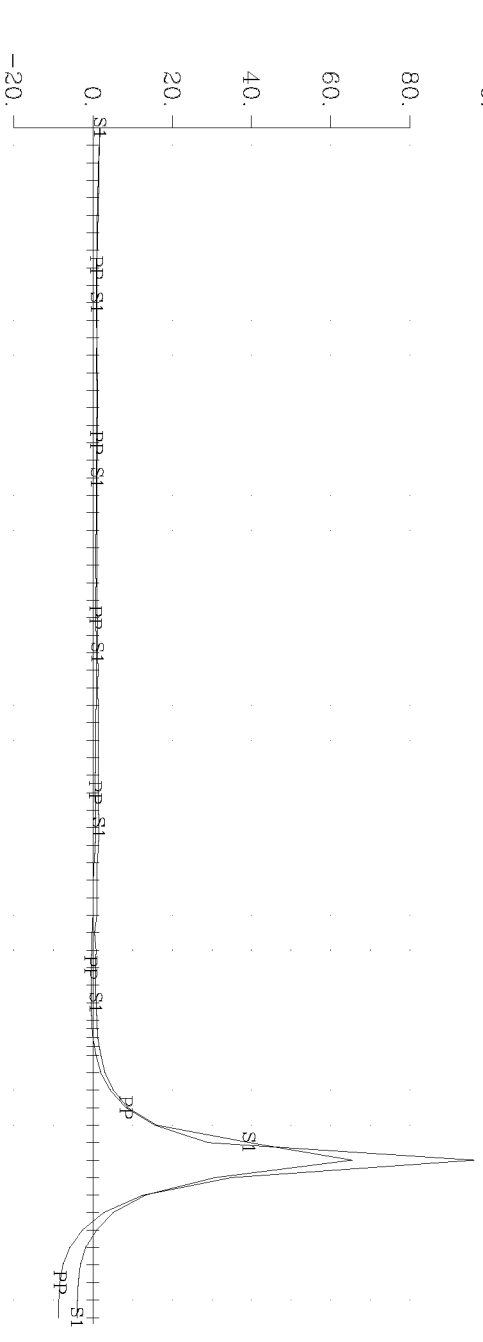

Step Channels 2-4.
 Deviations from S1.
 (% Total Theoretical)

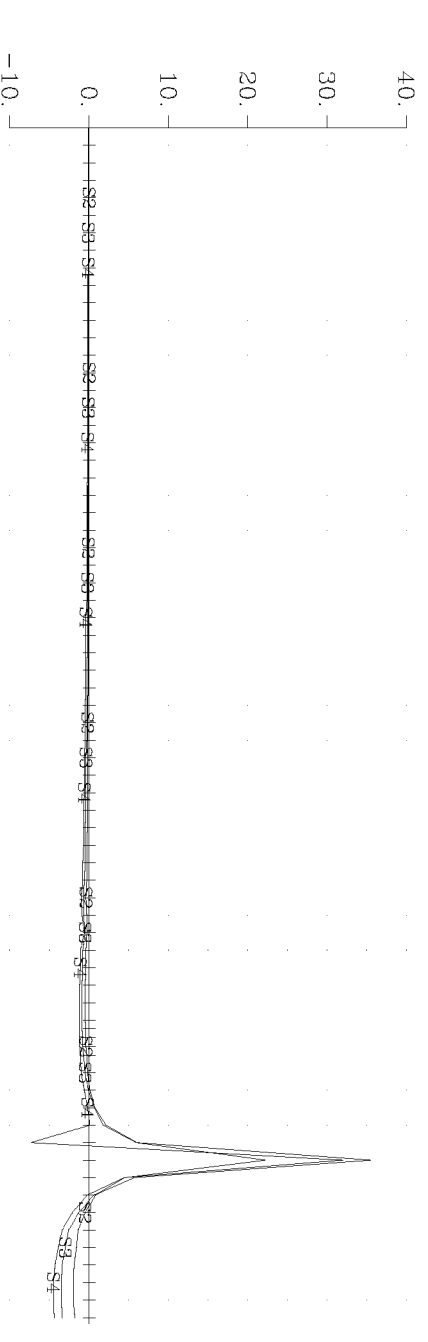

Pulse EM Off-time
 Channels 15-20
 (nT/sec)

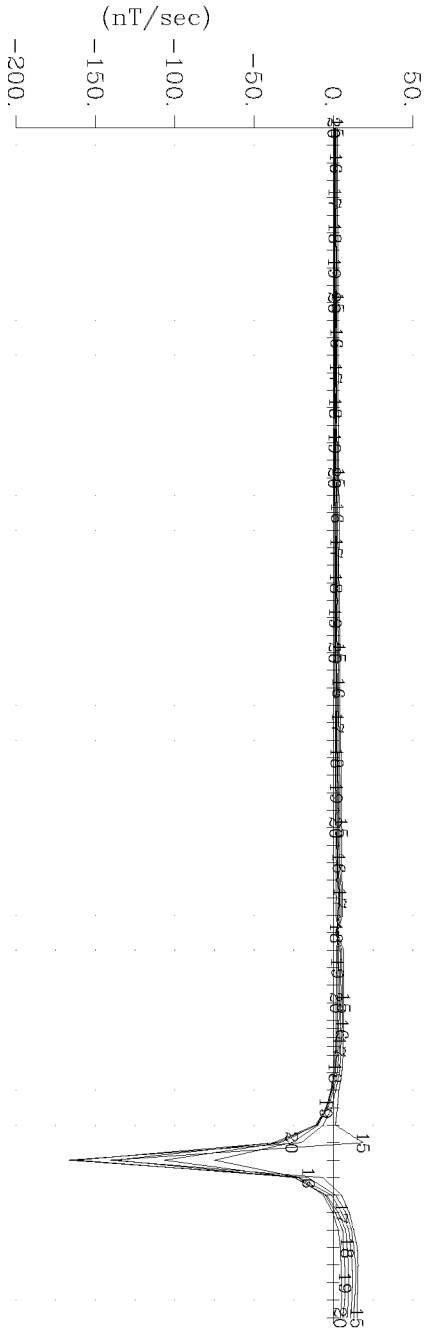

Ursa Major Minerals Inc. Shakespeare East Property
 Loop 1, Hole U-08-02 Z Component
 Crone Geophysics & Exploration Ltd.

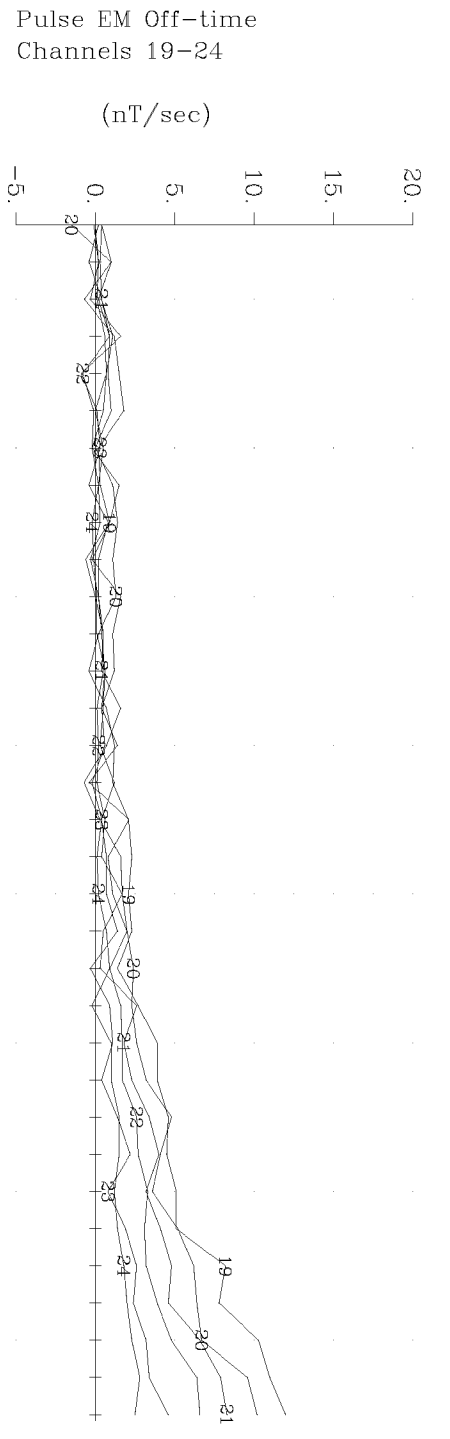
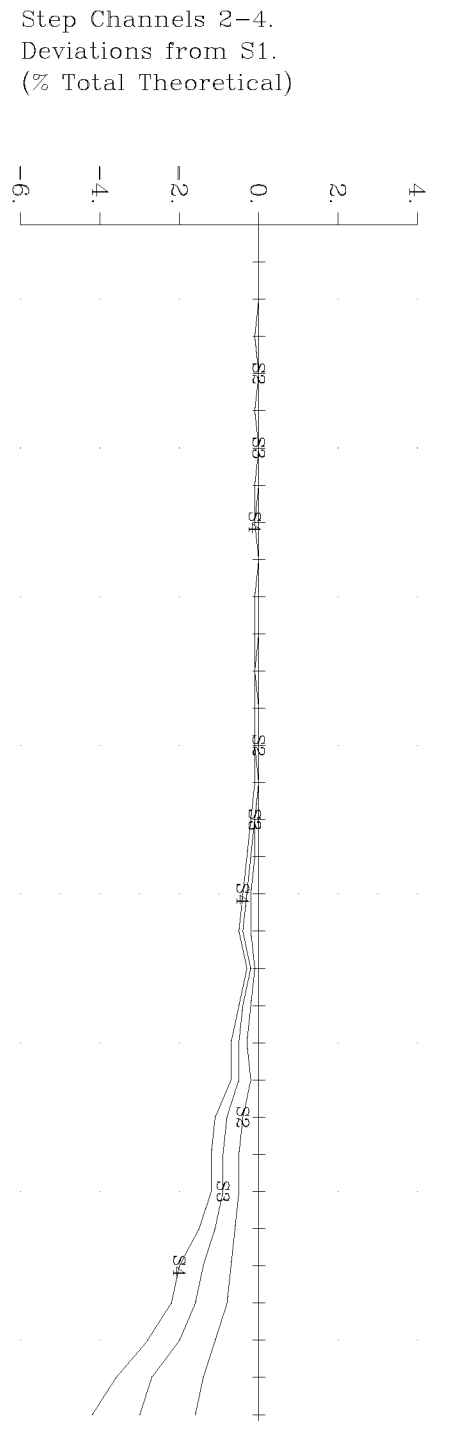
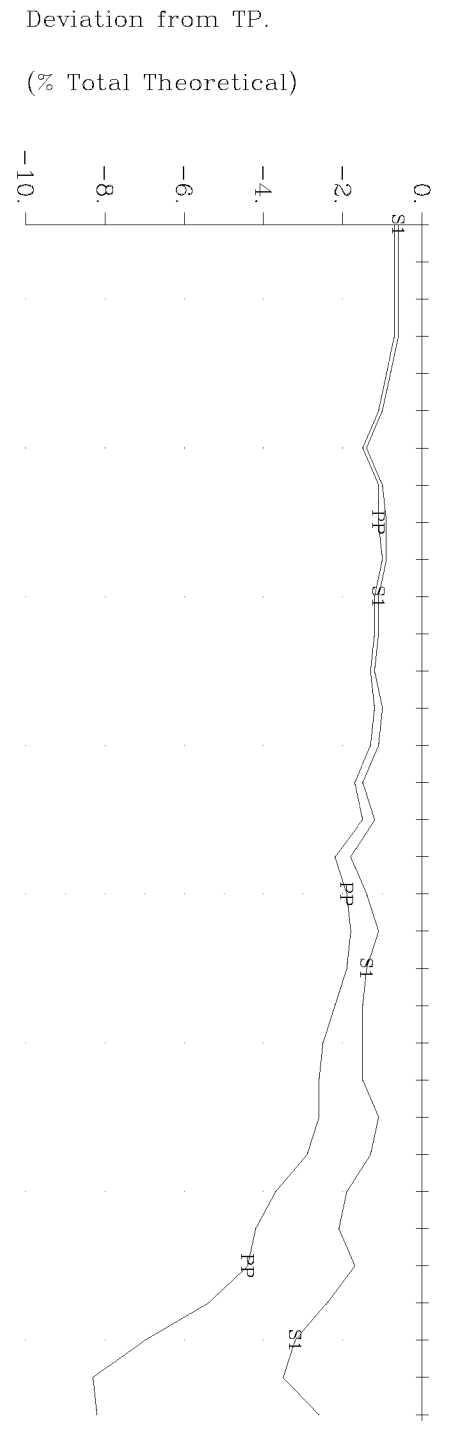
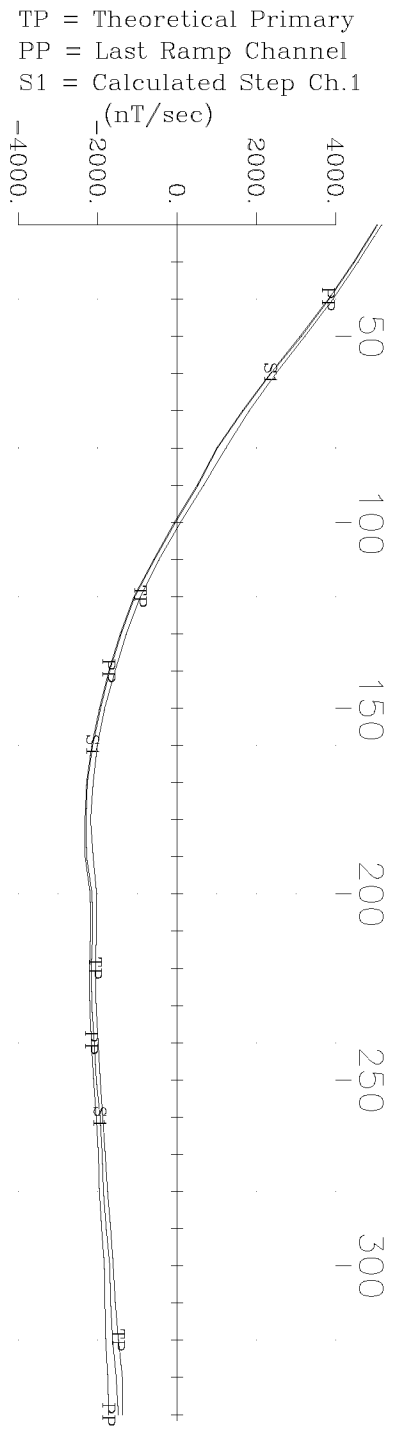

Ursa Major Minerals Inc. Shakespeare East Property
 Loop 1, Hole U-03-113 X Component
 Crone Geophysics & Exploration Ltd.

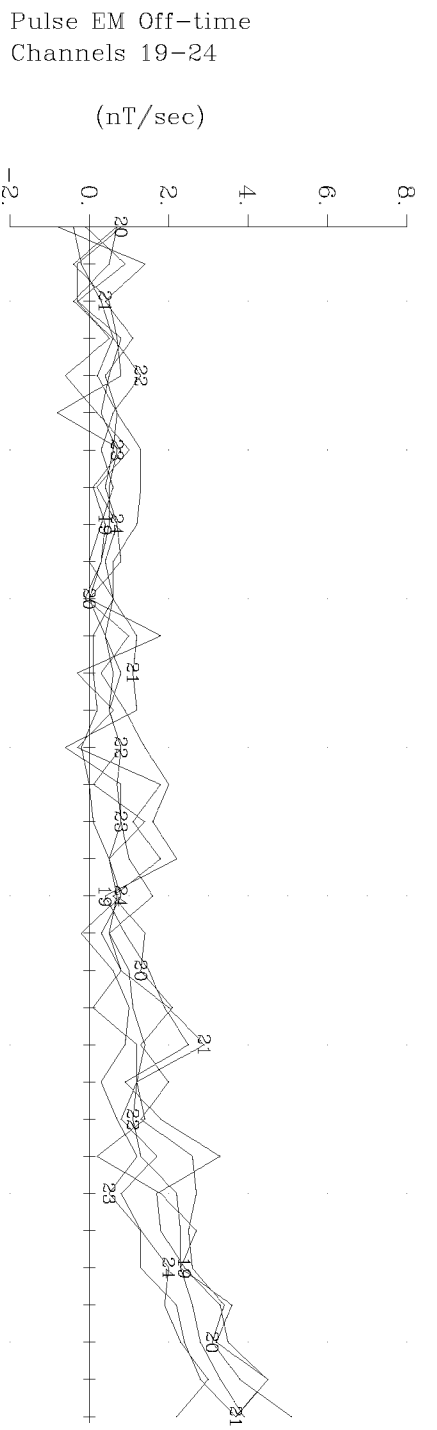
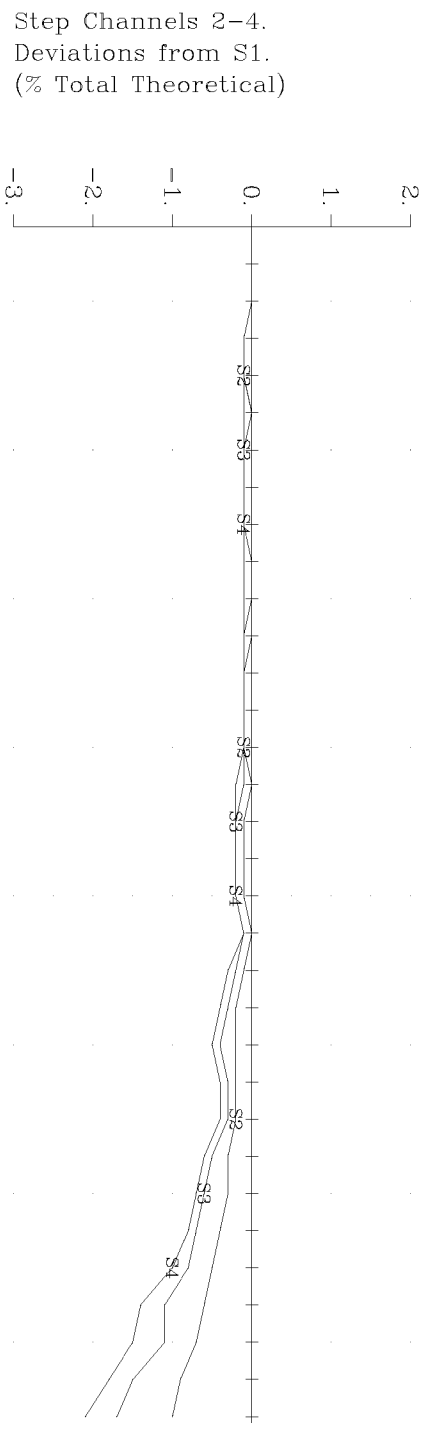
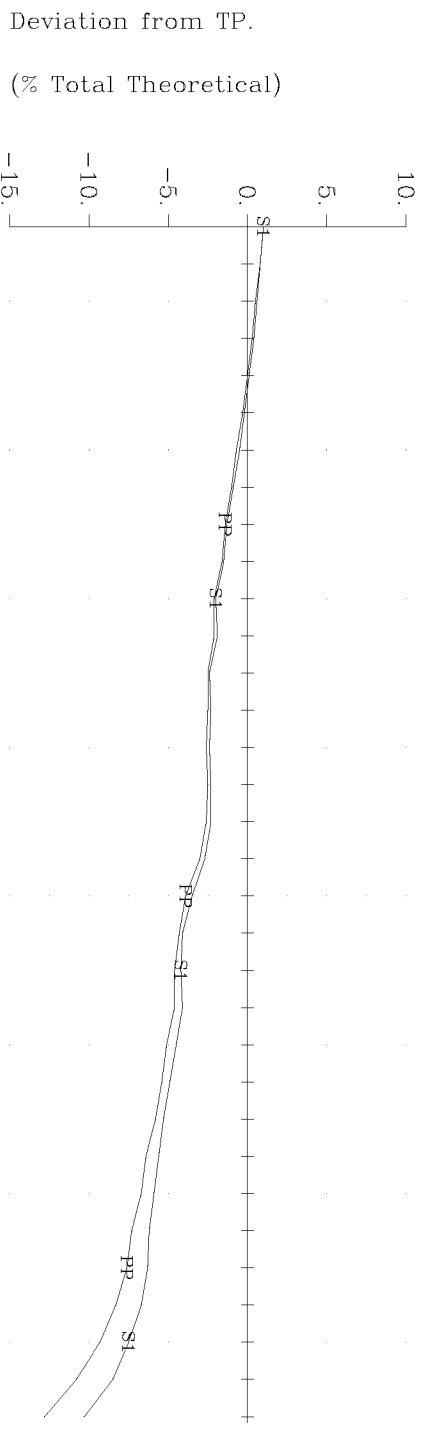
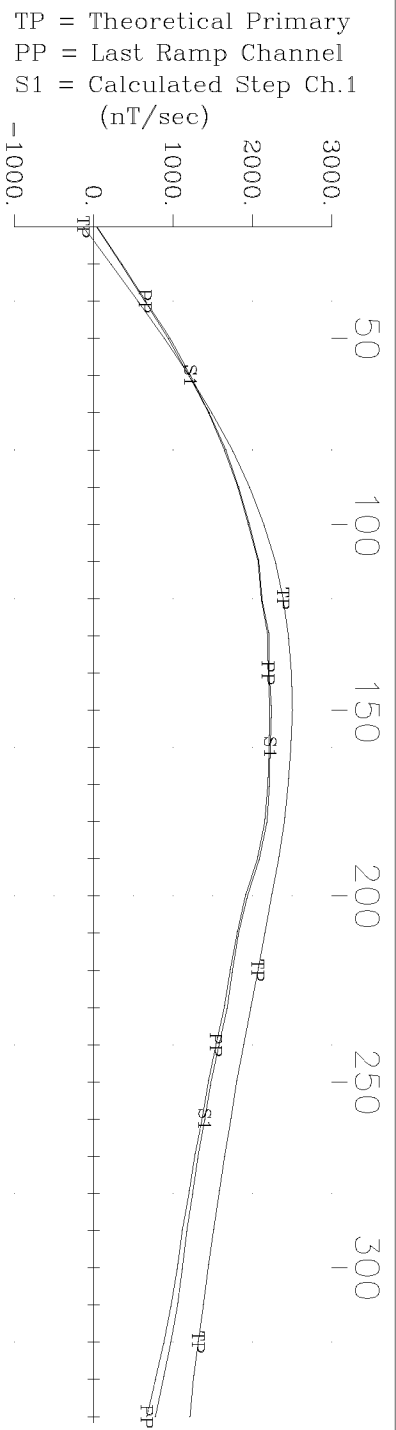

Ursa Major Minerals Inc. Shakespeare East Property
 Loop 1, Hole U-03-113 Y Component
 Crone Geophysics & Exploration Ltd.

TP = Theoretical Primary
 PP = Last Ramp Channel
 S1 = Calculated Step Ch.1
 (nT/sec)

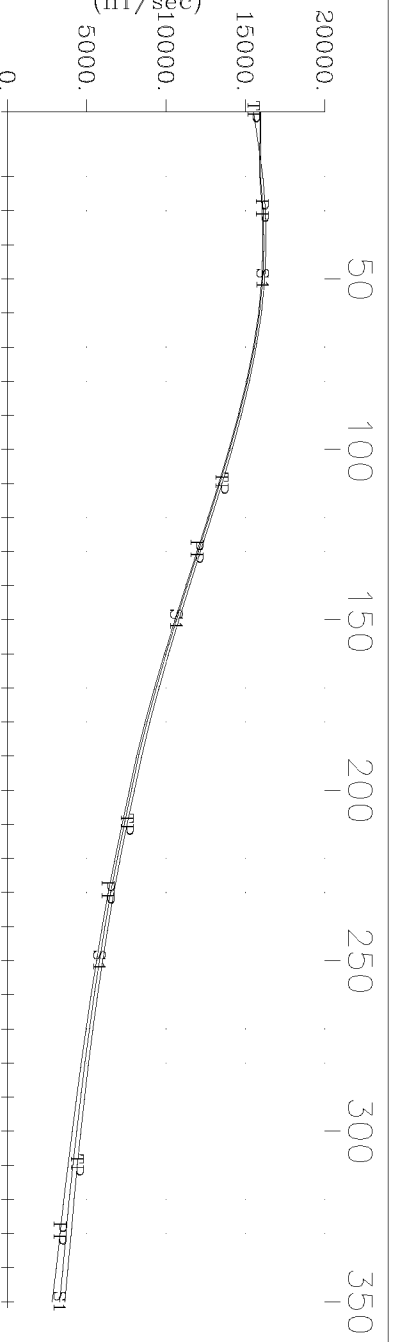

Deviation from TP.
 (% Total Theoretical)

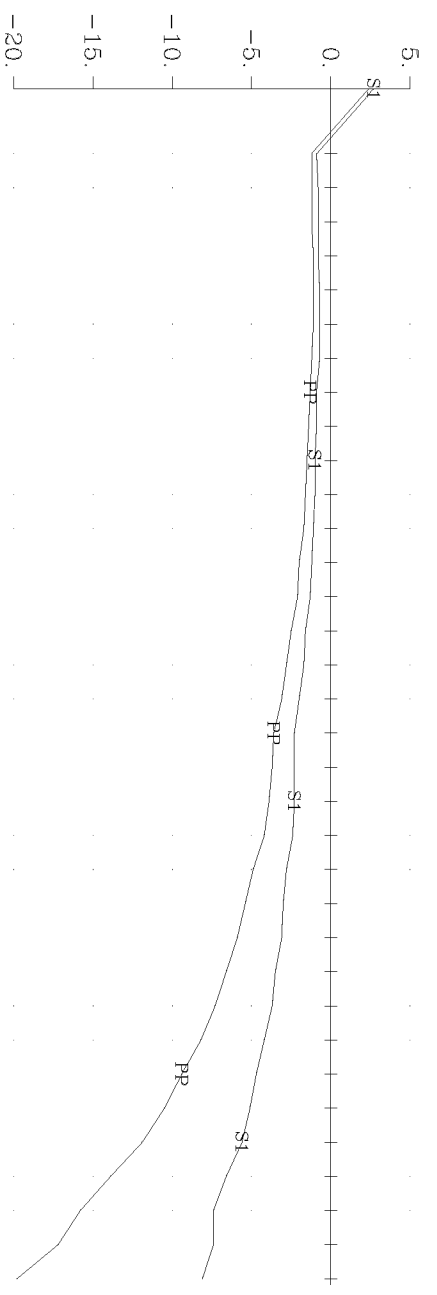

Step Channels 2-4.
 Deviations from S1.
 (% Total Theoretical)

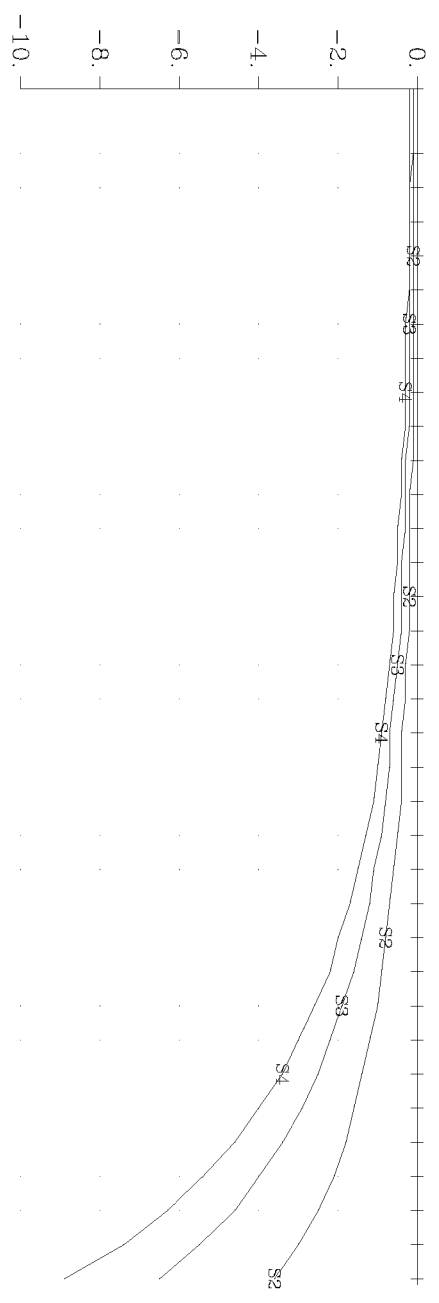

Pulse EM Off-time
 Channels 19-24
 (nT/sec)

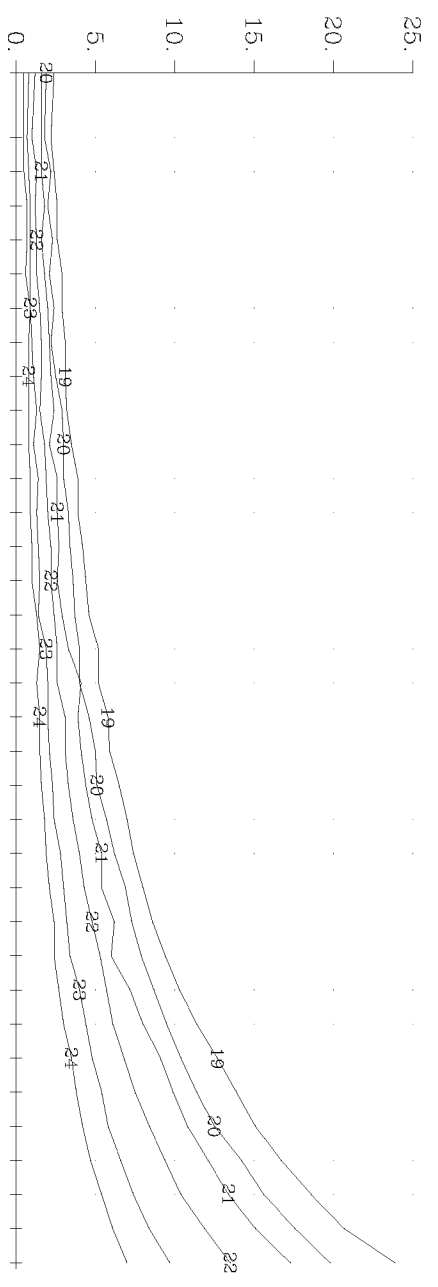

Ursa Major Minerals Inc. Shakespeare East Property
 Loop 1, Hole U-03-113 Z Component
 Crone Geophysics & Exploration Ltd.

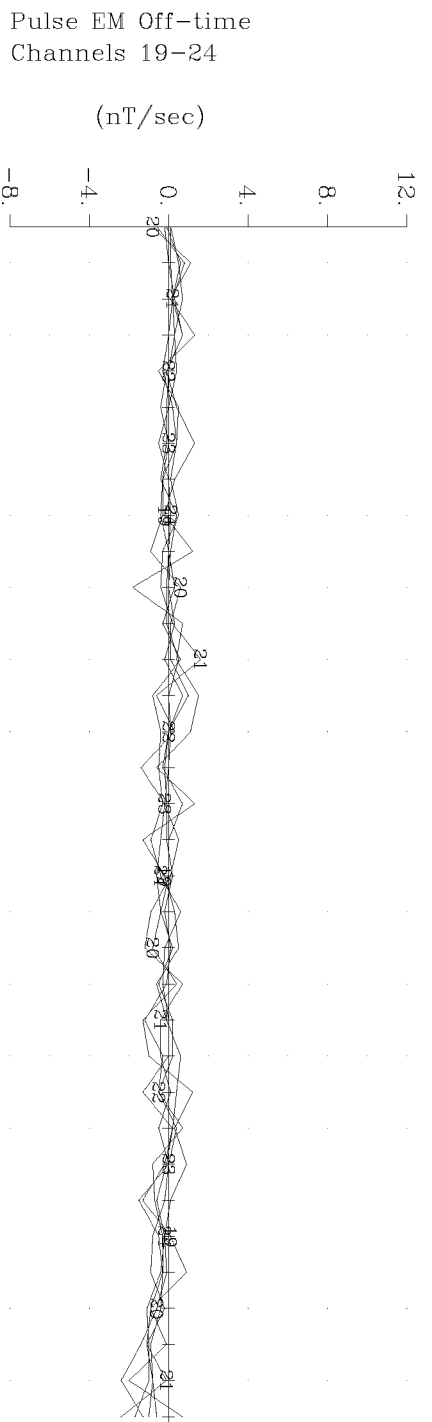
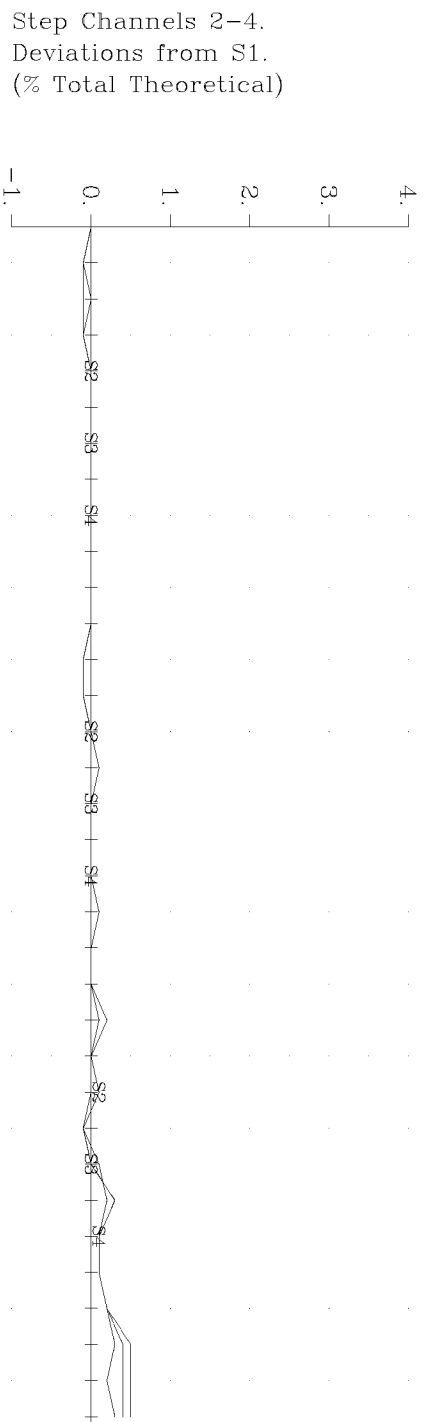
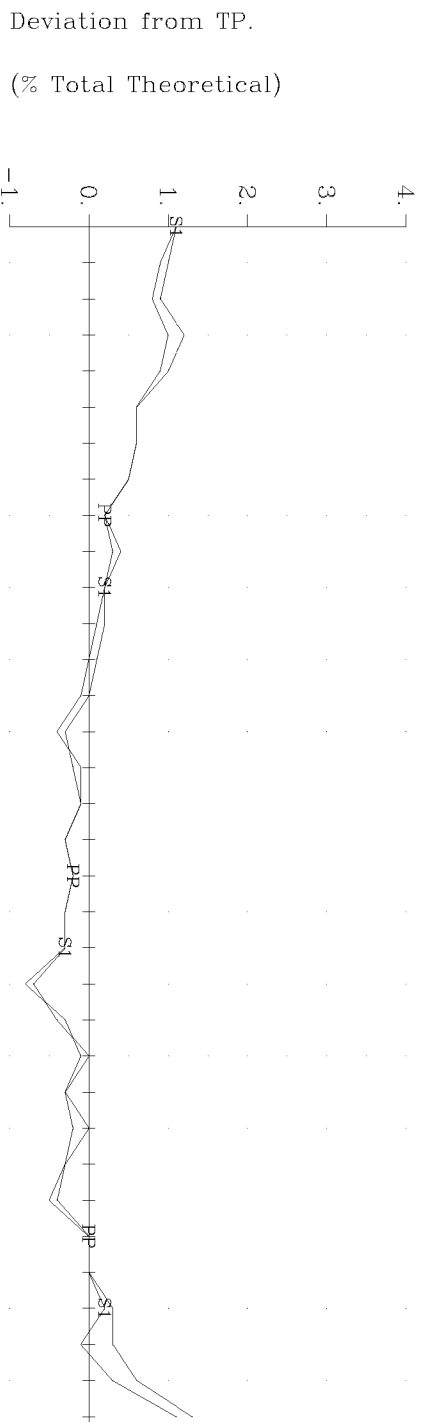
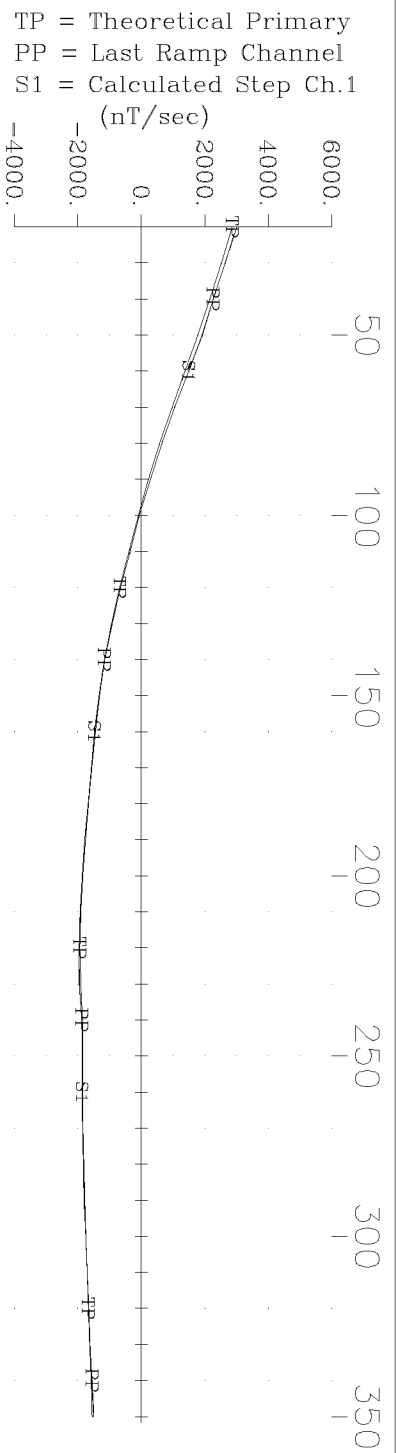

Ursa Major Minerals Inc. Shakespeare East Property
 Loop 1, Hole U-03-114 X Component
 Crone Geophysics & Exploration Ltd.

TP = Theoretical Primary
 PP = Last Ramp Channel
 S1 = Calculated Step Ch.1
 (nT/sec)

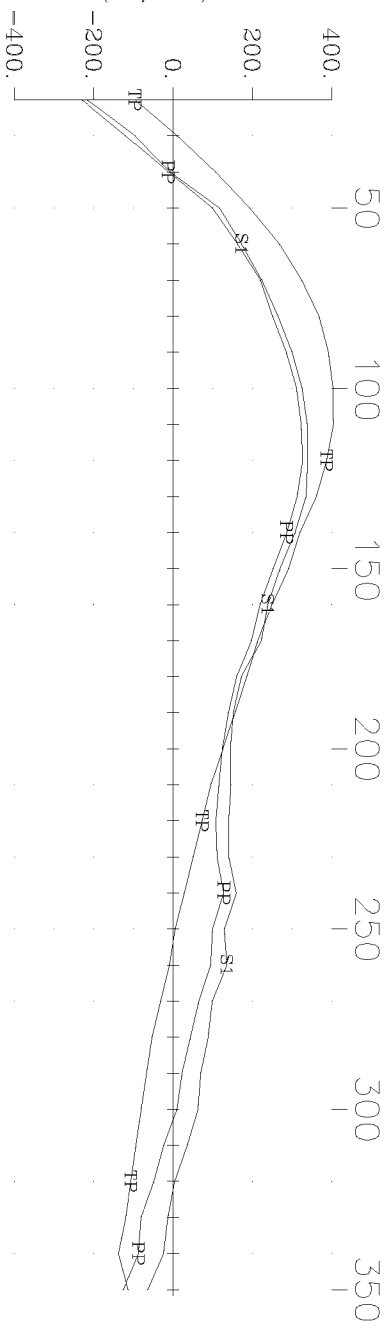

Deviation from TP.
 (% Total Theoretical)

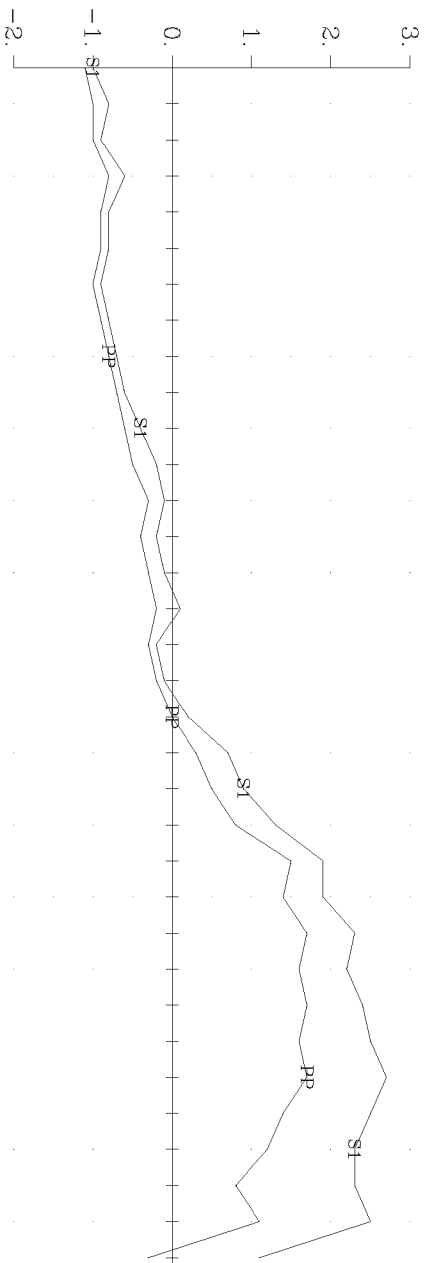

Step Channels 2-4.
 Deviations from S1.
 (% Total Theoretical)

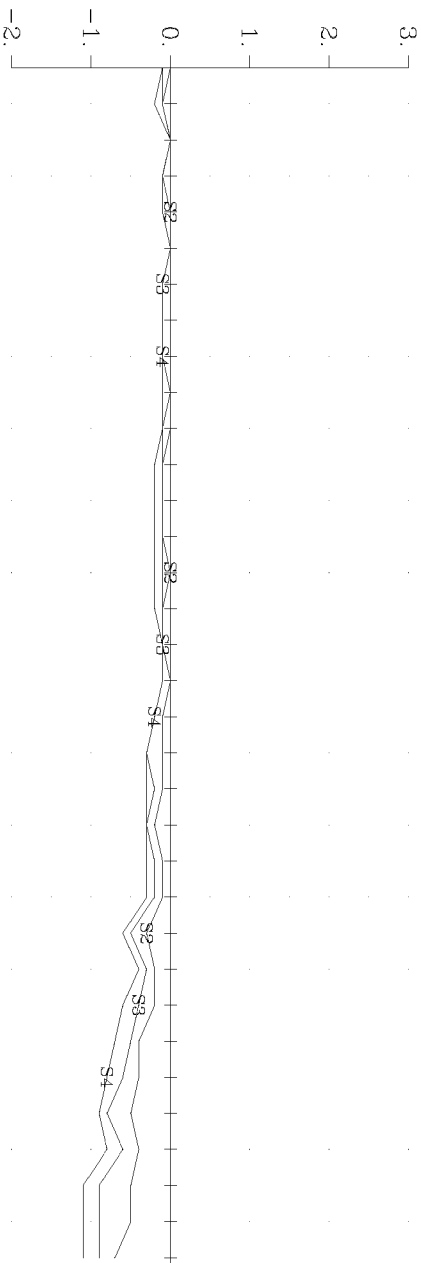

Pulse EM Off-time
 Channels 19-24
 (nT/sec)

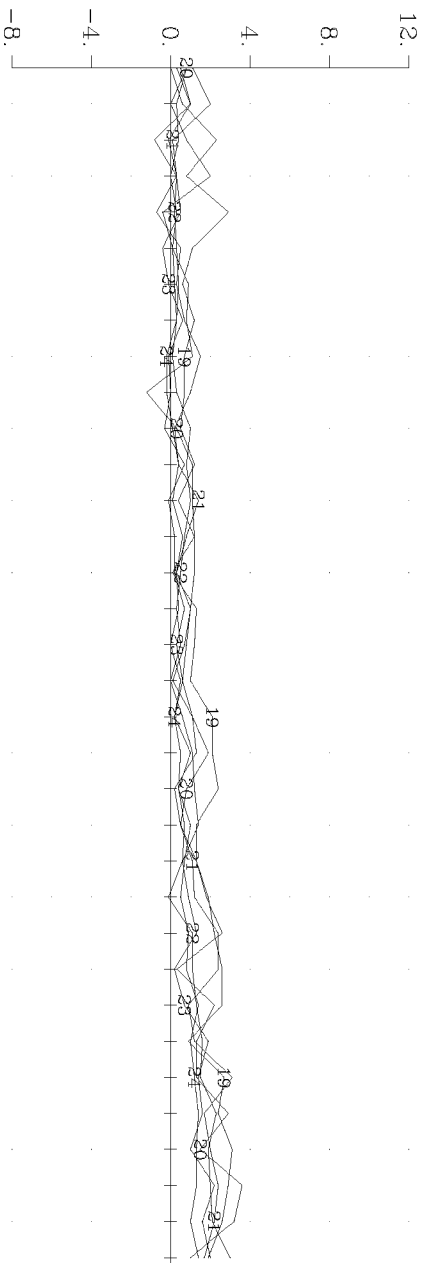

Ursa Major Minerals Inc. Shakespeare East Property
 Loop 1, Hole U-03-114 Y Component
 Crone Geophysics & Exploration Ltd.

TP = Theoretical Primary
 PP = Last Ramp Channel
 S1 = Calculated Step Ch.1

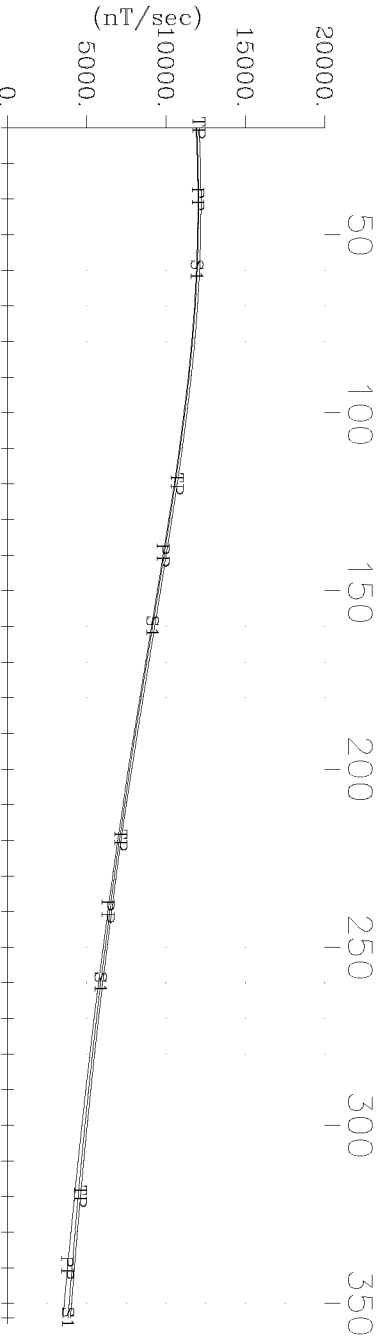

Deviation from TP.
 (% Total Theoretical)

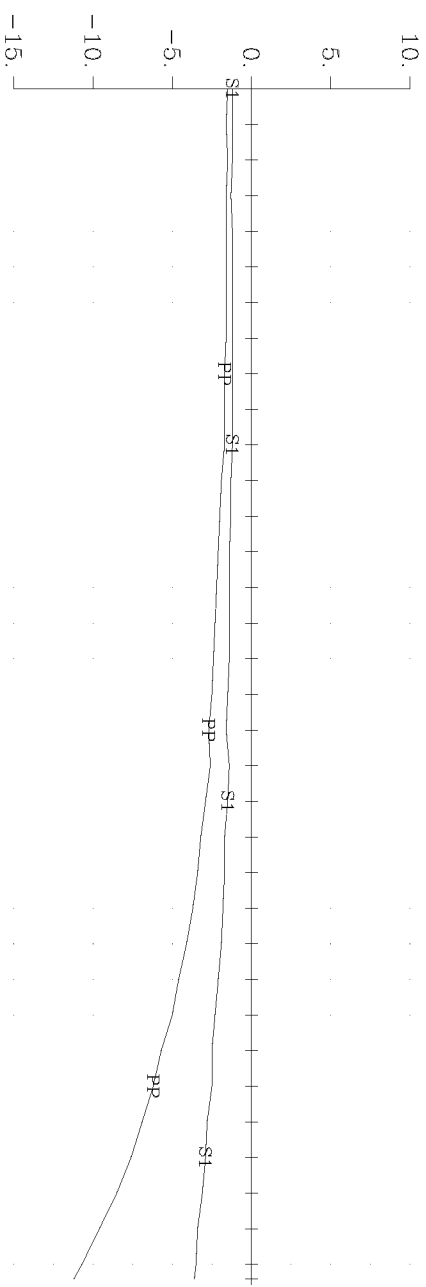

Step Channels 2-4.
 Deviations from S1.
 (% Total Theoretical)

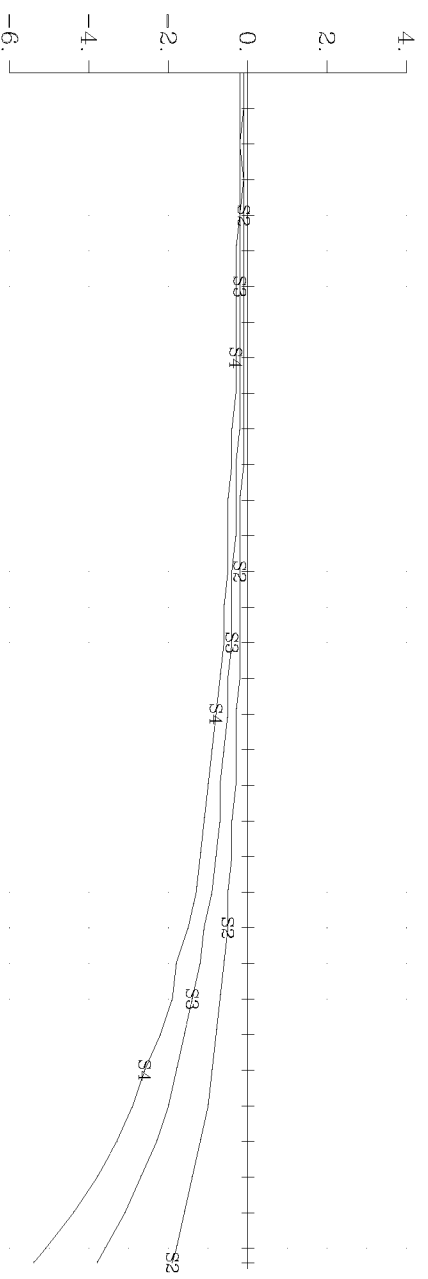

Pulse EM Off-time
 Channels 19-24
 (nT/sec)

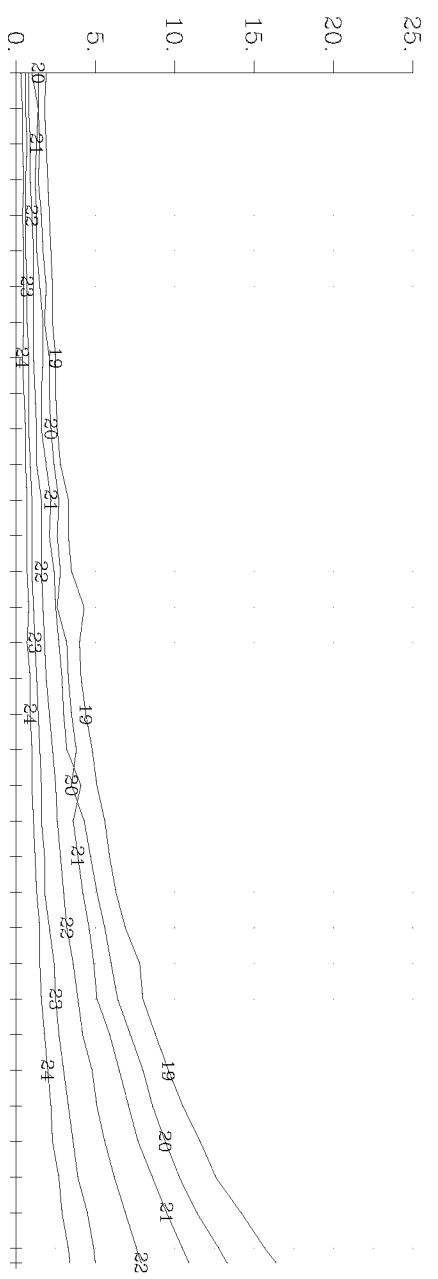

Ursa Major Minerals Inc. Shakespeare East Property
 Loop 1, Hole U-03-114 Z Component
 Crone Geophysics & Exploration Ltd.

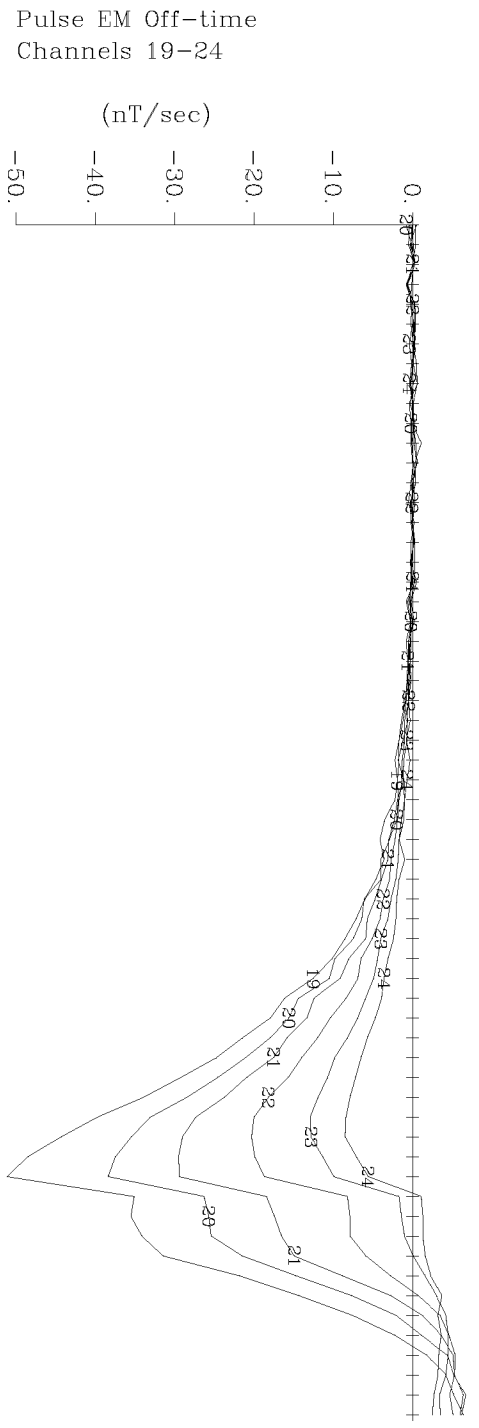
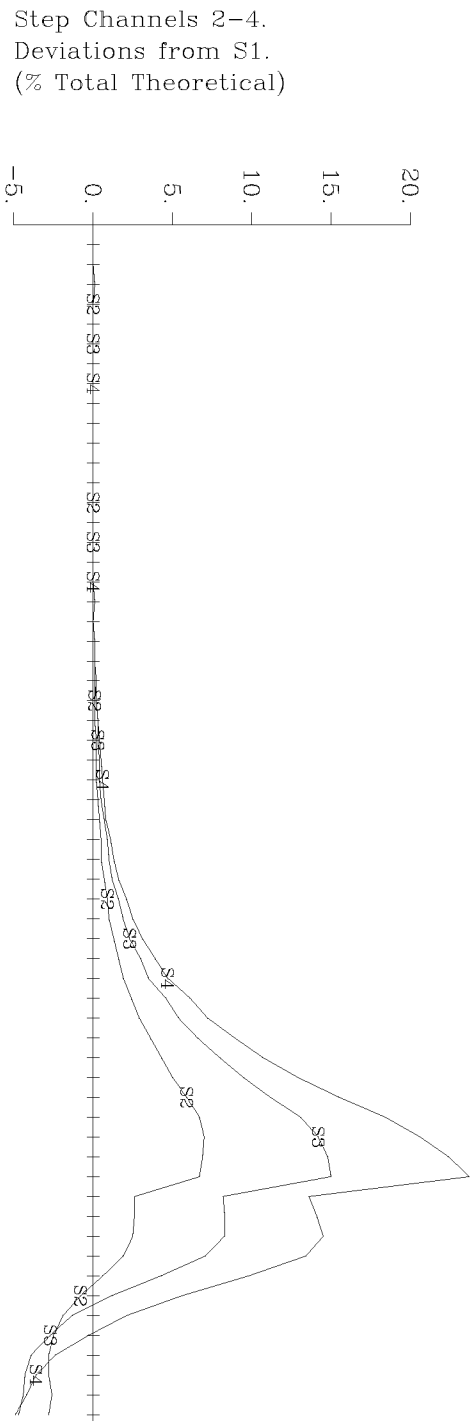
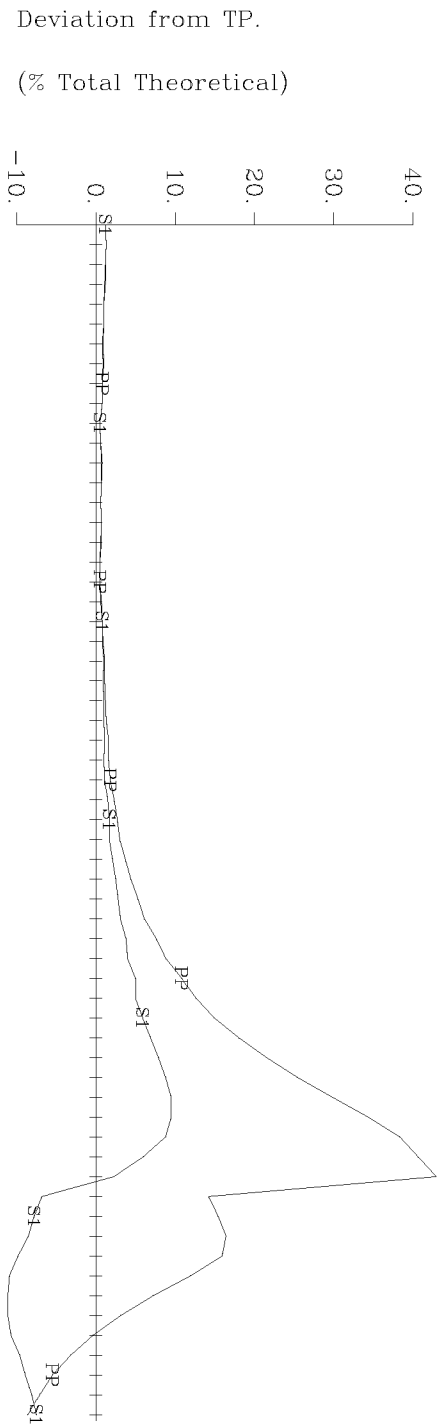
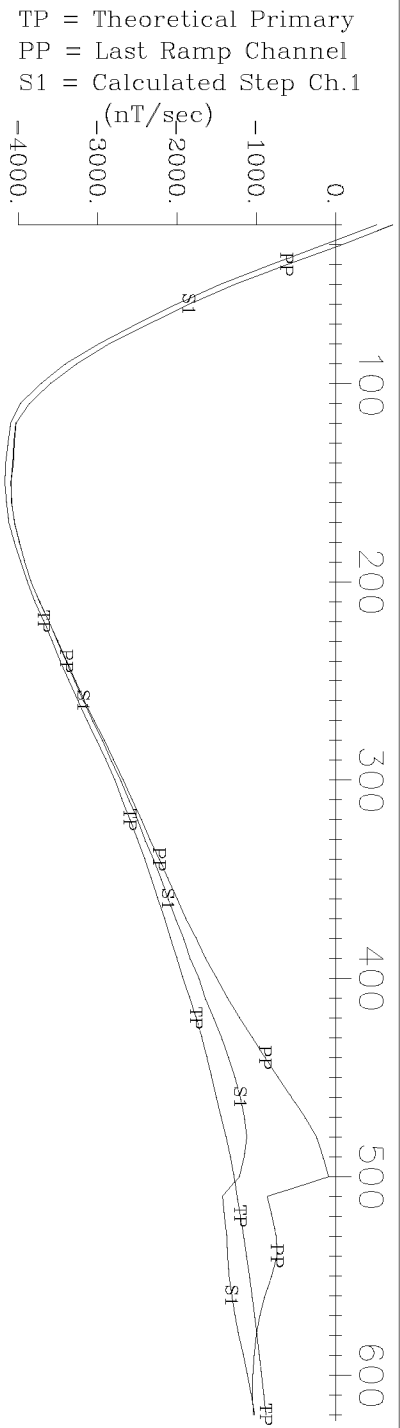

Ursa Major Minerals Inc. Shakespeare East Property
 Loop 1, Hole U-03-116 X Component
 Crone Geophysics & Exploration Ltd.

TP = Theoretical Primary
 PP = Last Ramp Channel
 S1 = Calculated Step Ch.1
 (nT/sec)

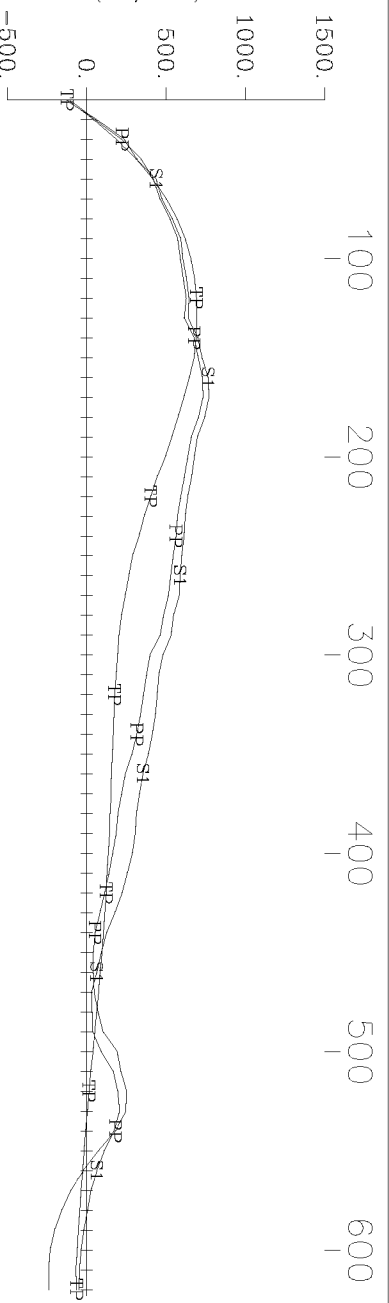

Deviation from TP.
 (% Total Theoretical)

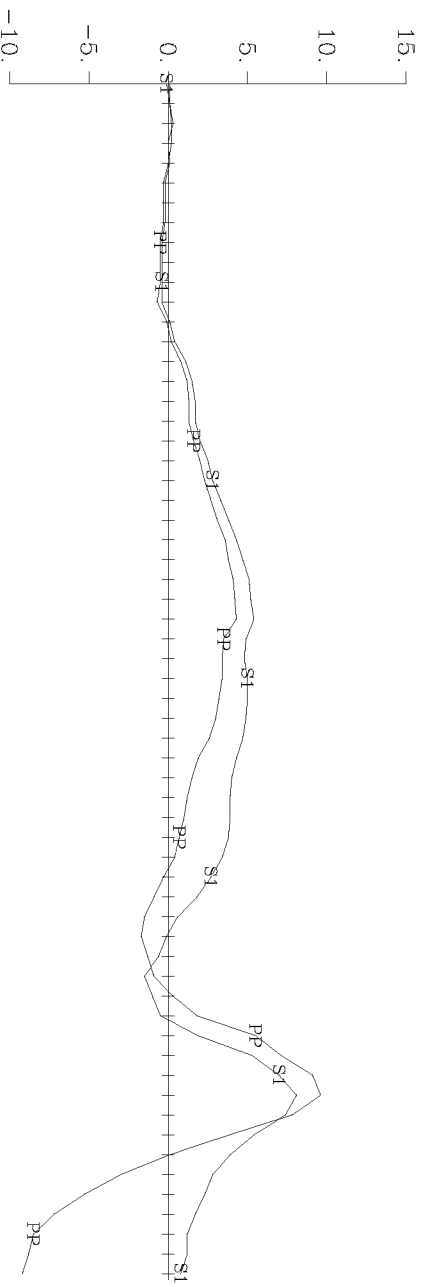

Step Channels 2-4.
 Deviations from S1.
 (% Total Theoretical)

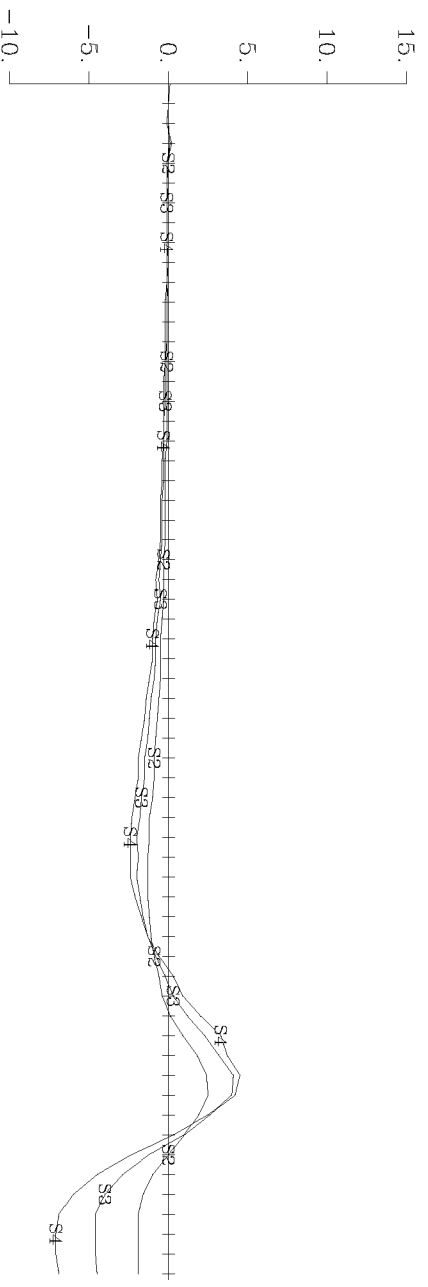

Pulse EM Off-time
 Channels 19-24
 (nT/sec)

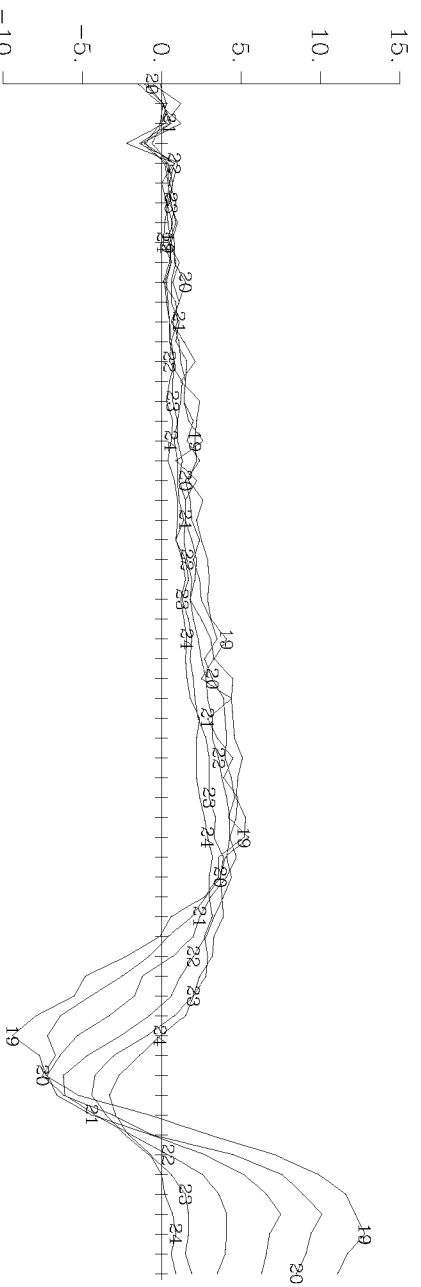

Ursa Major Minerals Inc. Shakespeare East Property
 Loop 1, Hole U-03-116 Y Component
 Crone Geophysics & Exploration Ltd.

TP = Theoretical Primary
 PP = Last Ramp Channel
 S1 = Calculated Step Ch.1

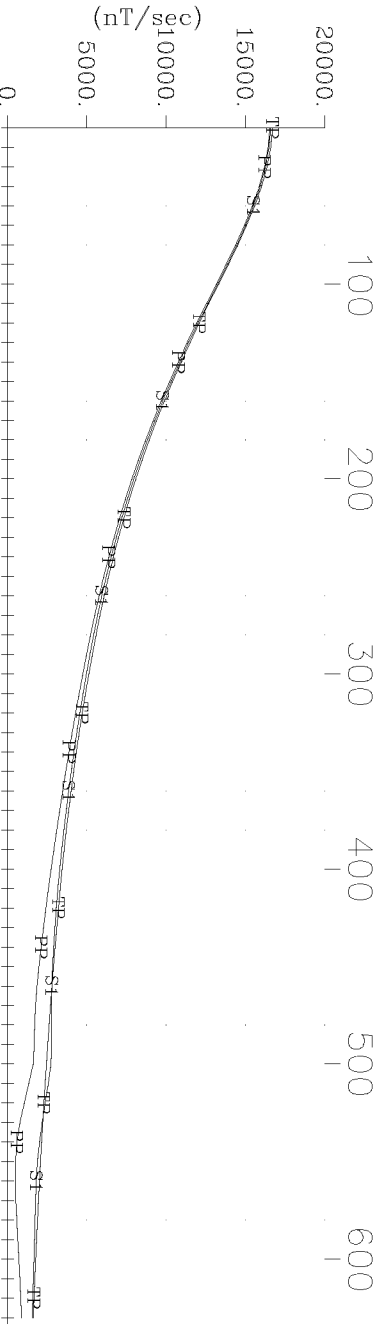

Deviation from TP.
 (% Total Theoretical)

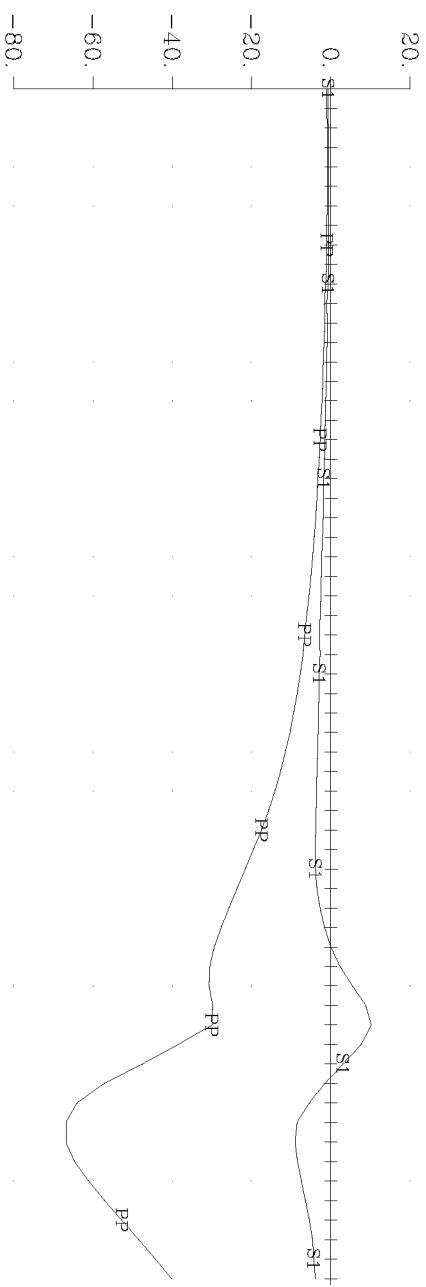

Step Channels 2-4.
 Deviations from S1.
 (% Total Theoretical)

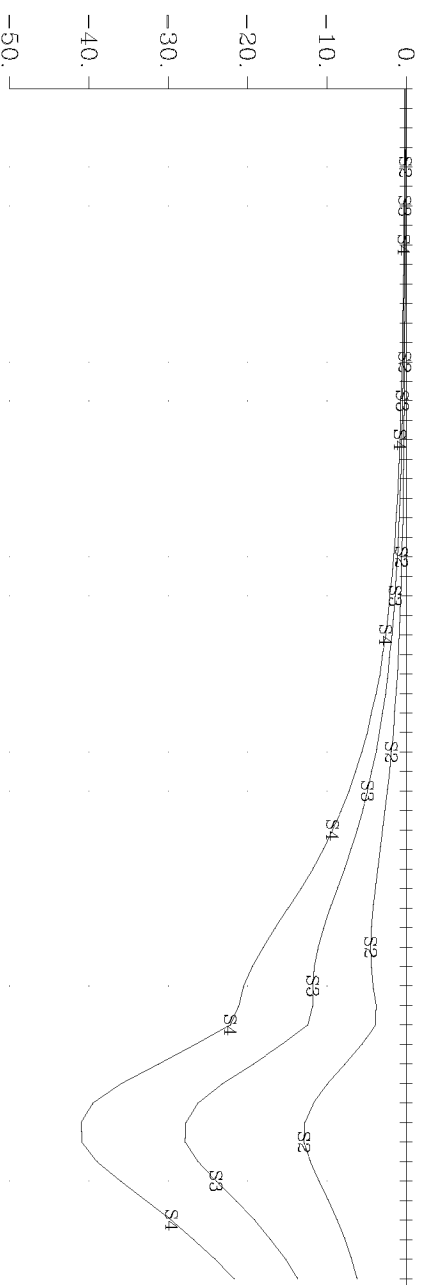

Pulse EM Off-time
 Channels 19-24
 (nT/sec)

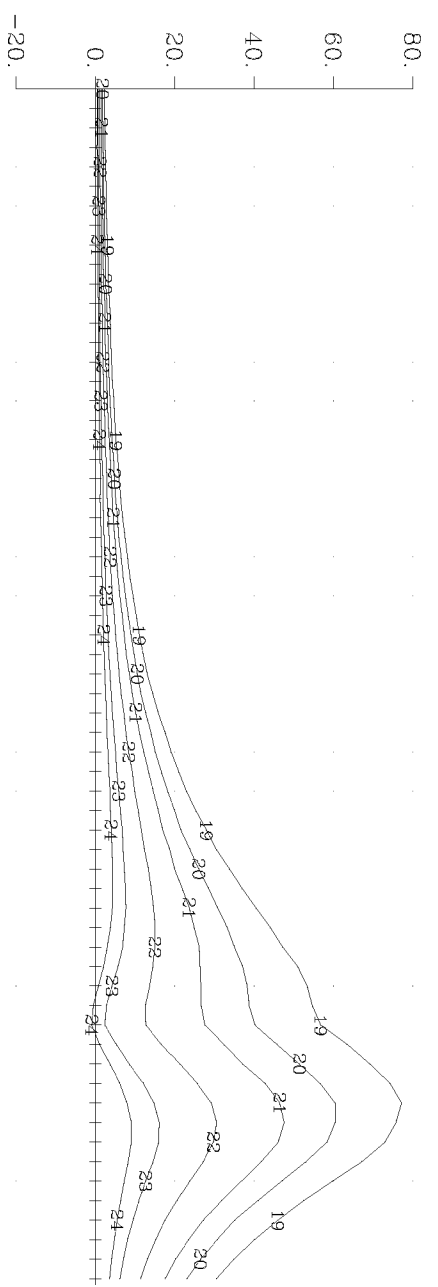

Ursa Major Minerals Inc. Shakespeare East Property
 Loop 1, Hole U-03-116 Z Component
 Crone Geophysics & Exploration Ltd.

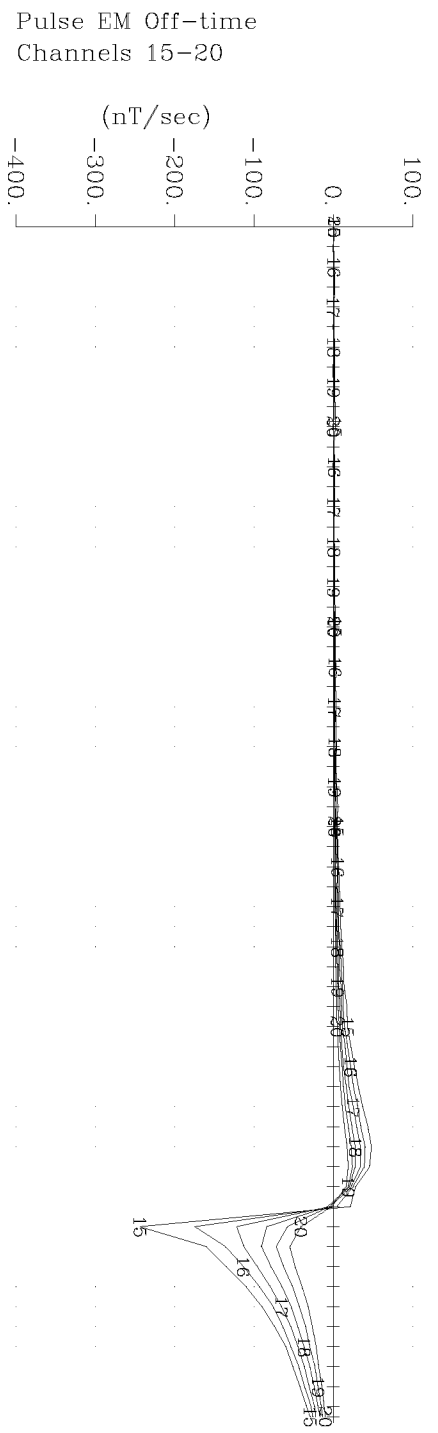
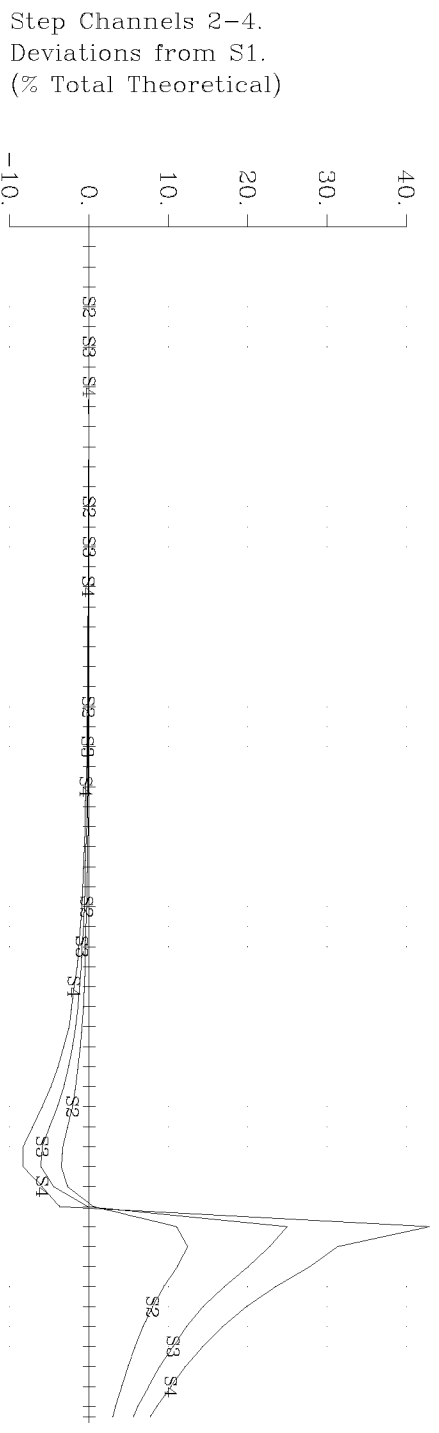
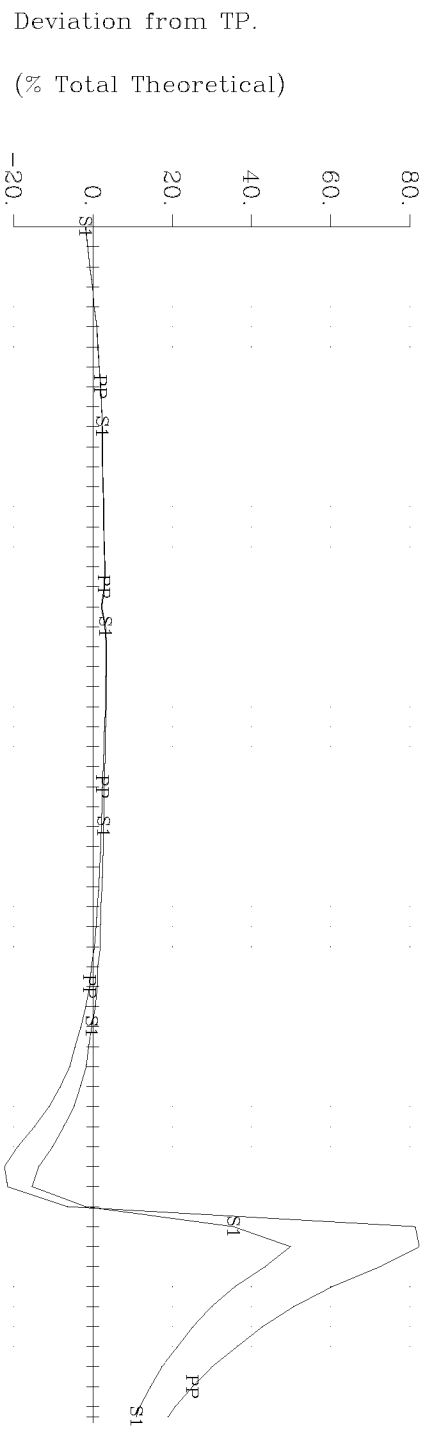
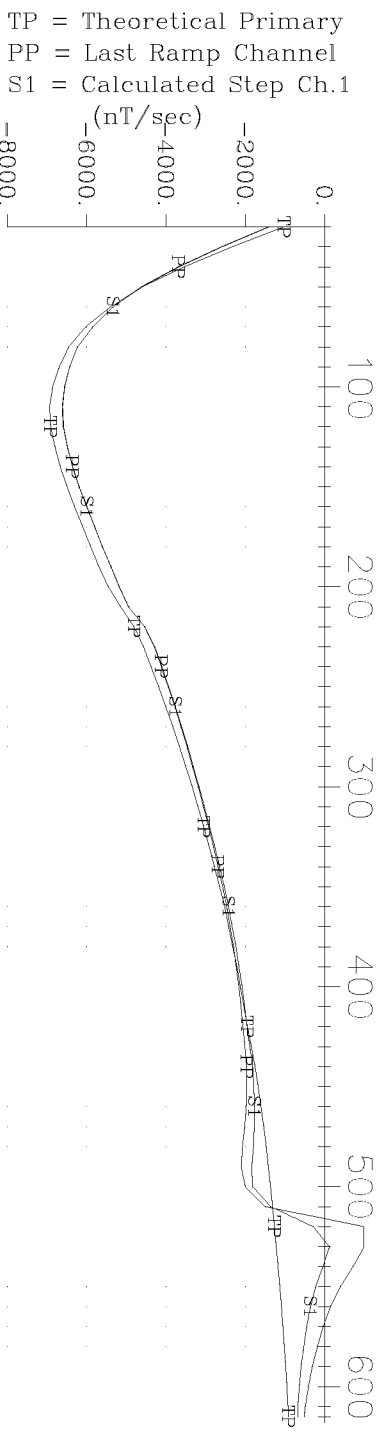

Ursa Major Minerals Inc. Shakespeare East Property
 Loop 1, Hole U-03-118 X Component
 Crone Geophysics & Exploration Ltd.

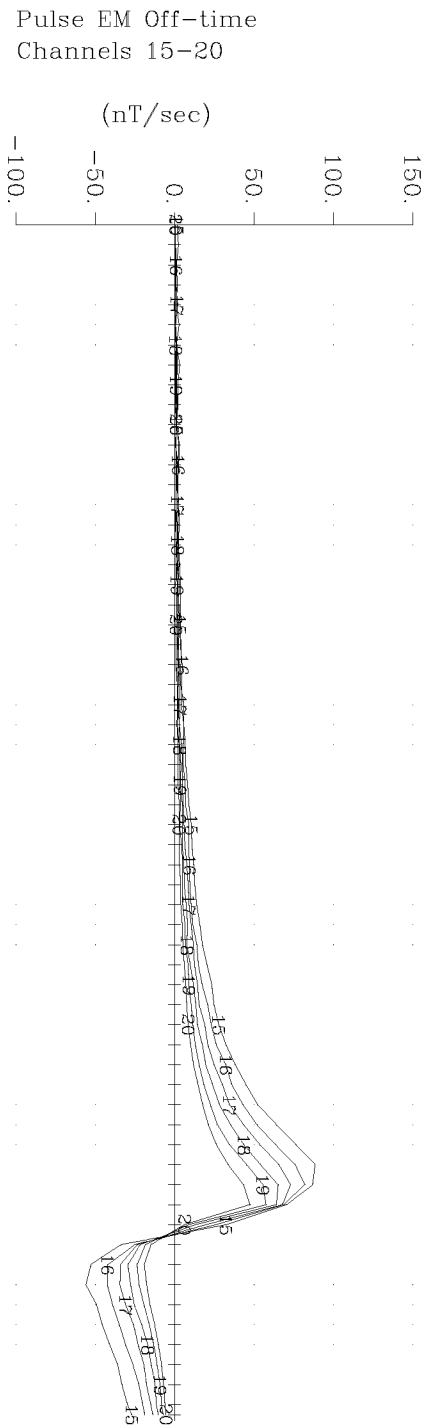
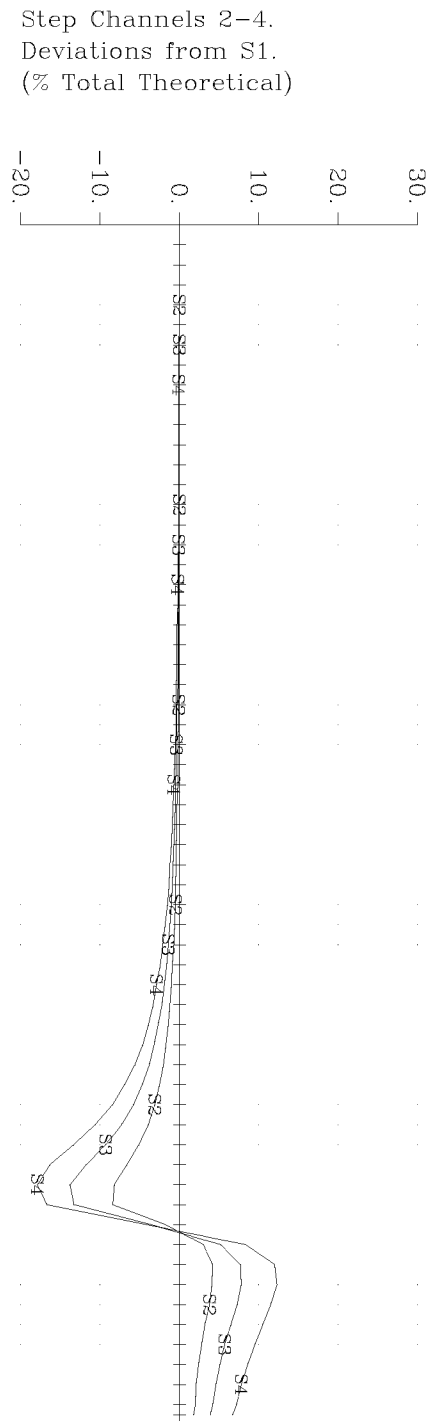
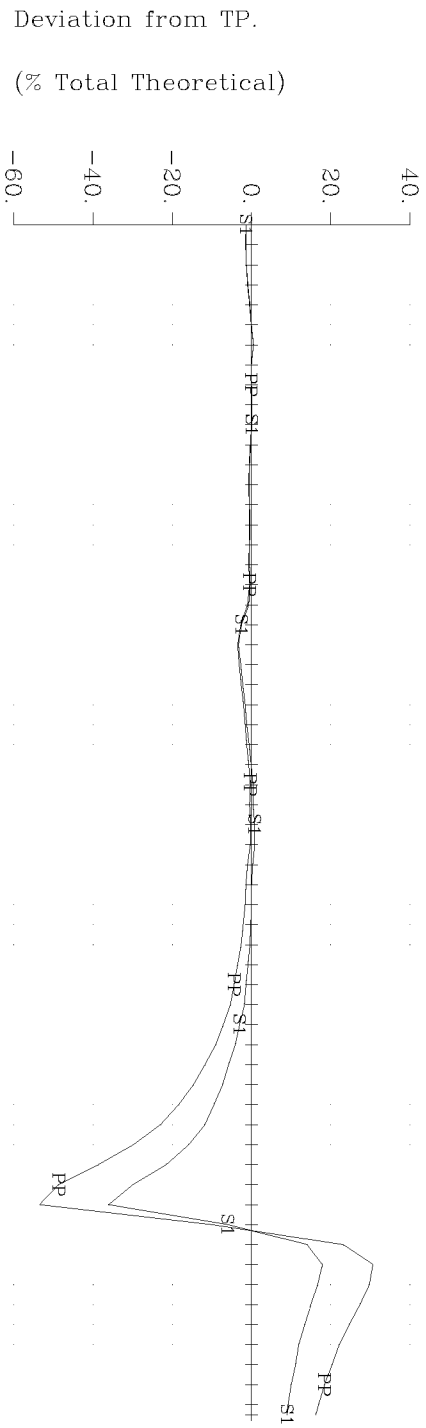
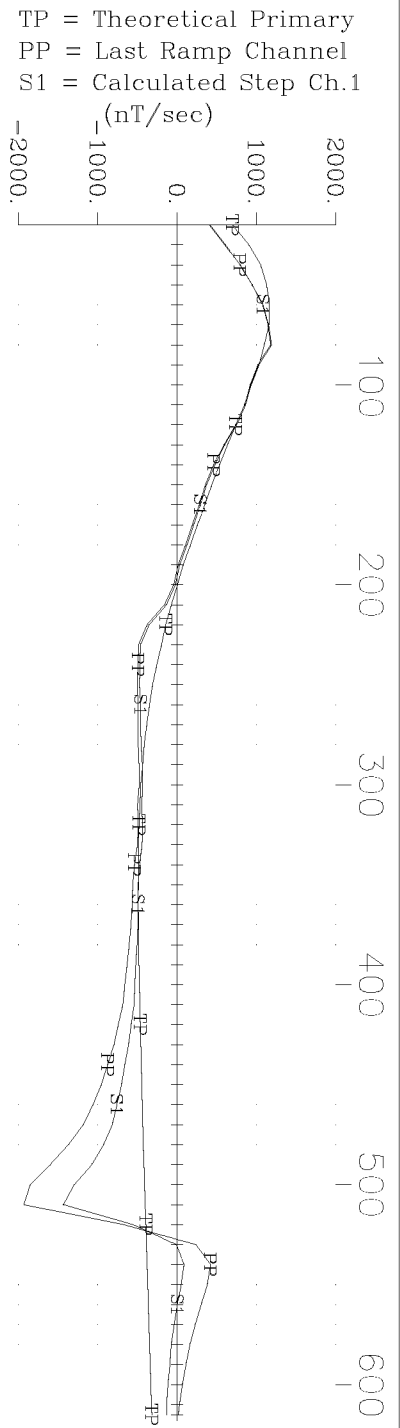

Ursa Major Minerals Inc. Shakespeare East Property
 Loop 1, Hole U-03-118 Y Component
 Crone Geophysics & Exploration Ltd.

TP = Theoretical Primary
 PP = Last Ramp Channel
 S1 = Calculated Step Ch.1

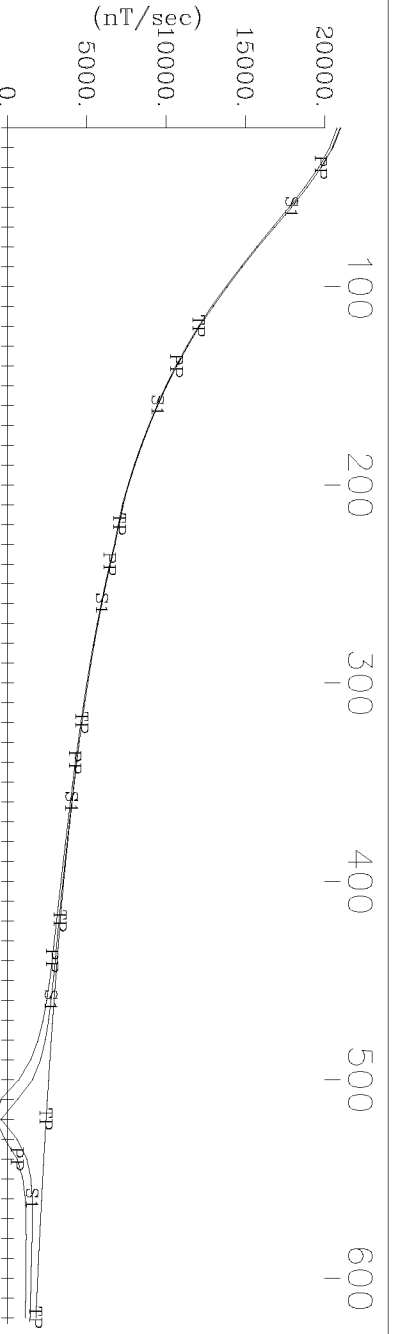

Deviation from TP.
 (% Total Theoretical)

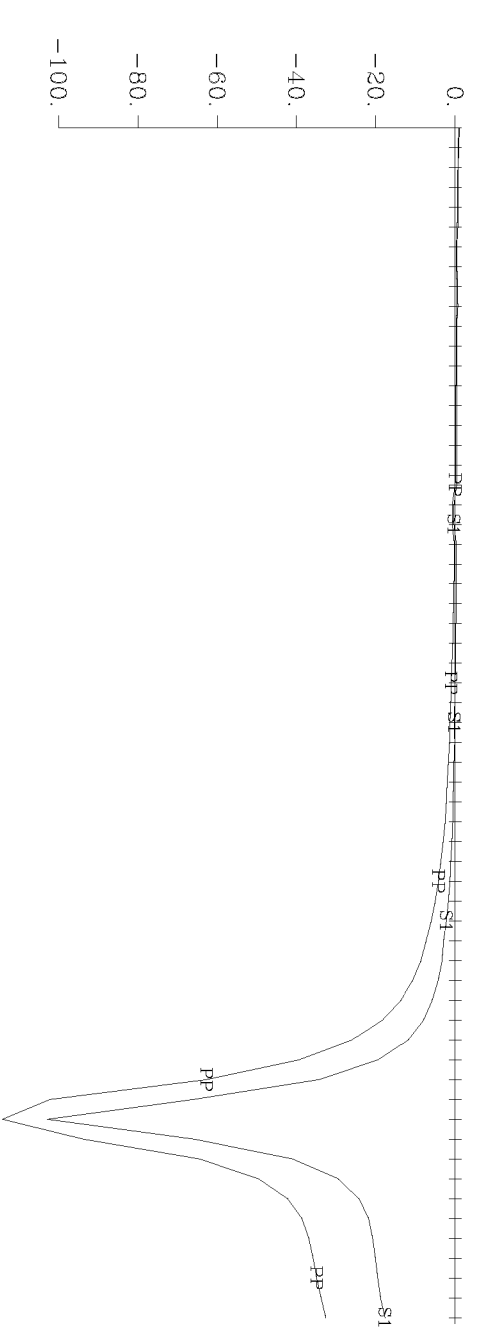

Step Channels 2-4.
 Deviations from S1.
 (% Total Theoretical)

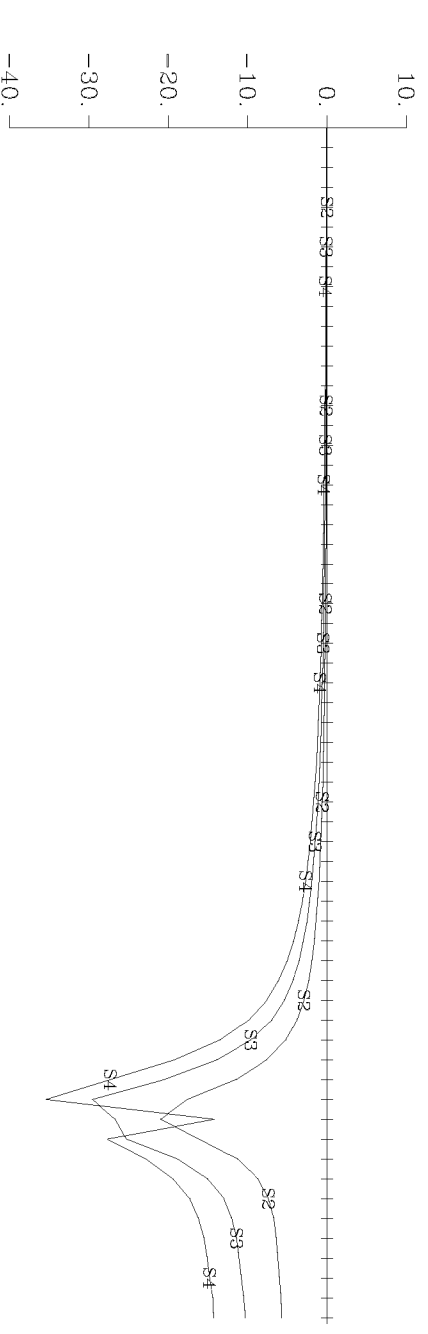

Pulse EM Off-time
 Channels 15-20
 (nT/sec)

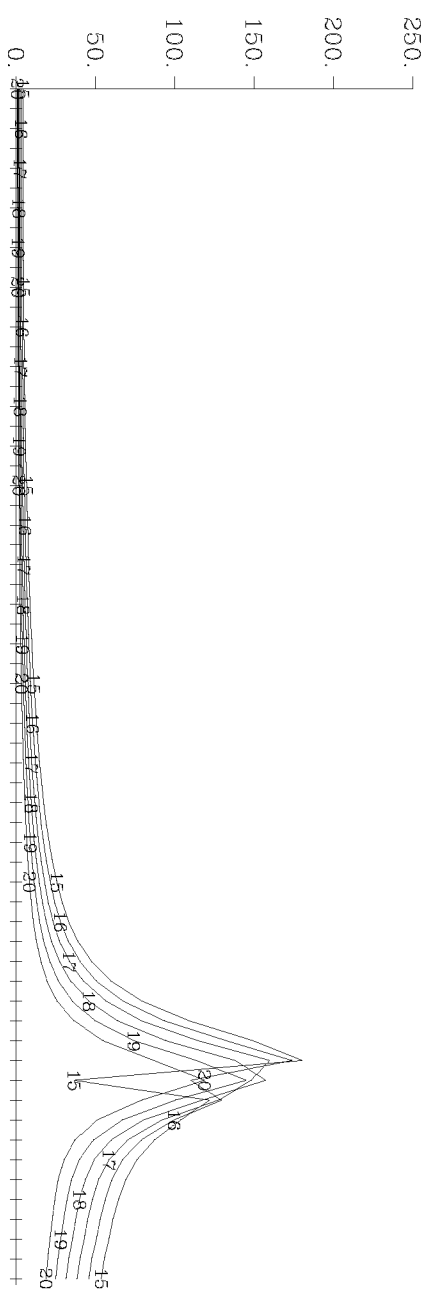

Ursa Major Minerals Inc. Shakespeare East Property
 Loop 1, Hole U-03-118 Z Component
 Crone Geophysics & Exploration Ltd.

TP = Theoretical Primary
 PP = Last Ramp Channel
 S1 = Calculated Step Ch.1
 (nT/sec)

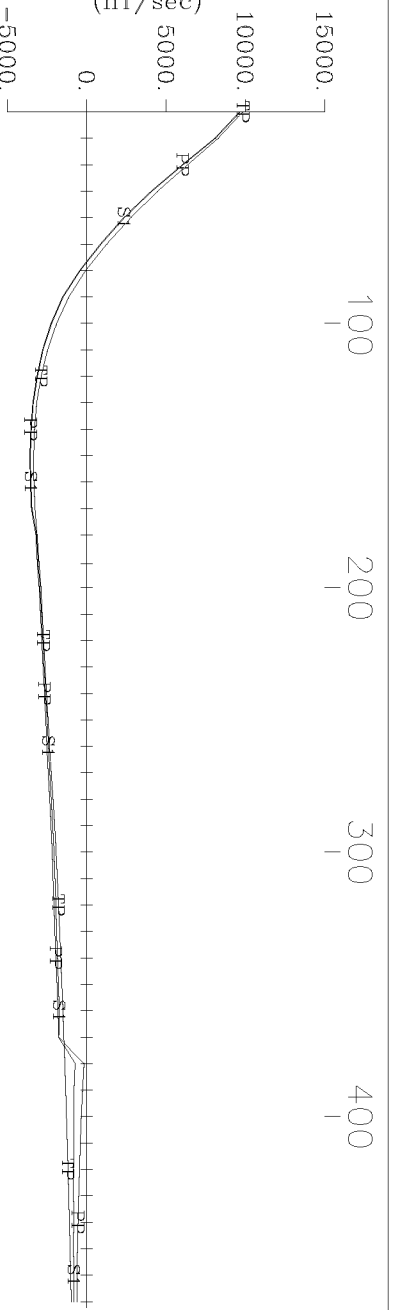

Deviation from TP.
 (% Total Theoretical)

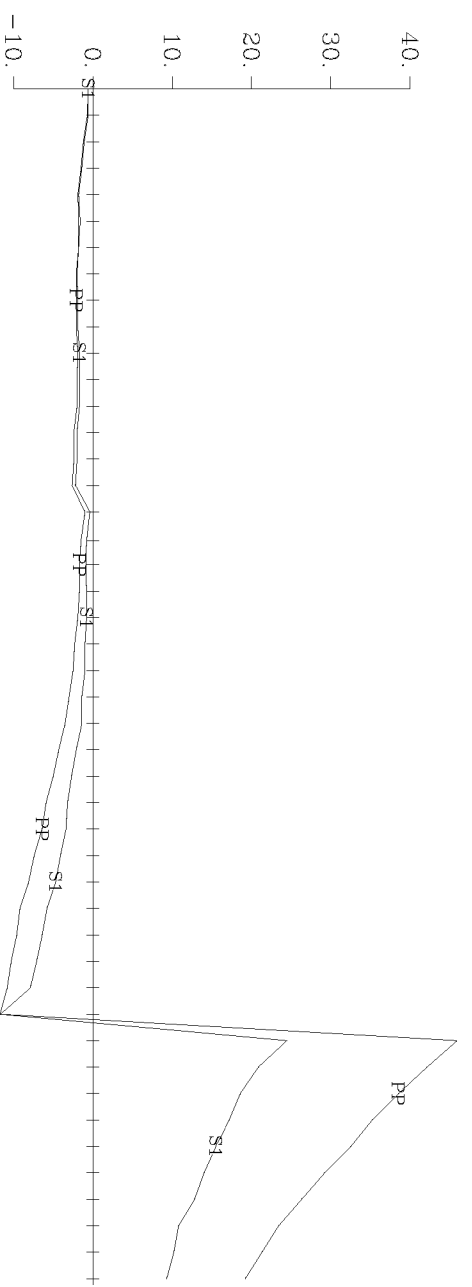

Step Channels 2-4.
 Deviations from S1.
 (% Total Theoretical)

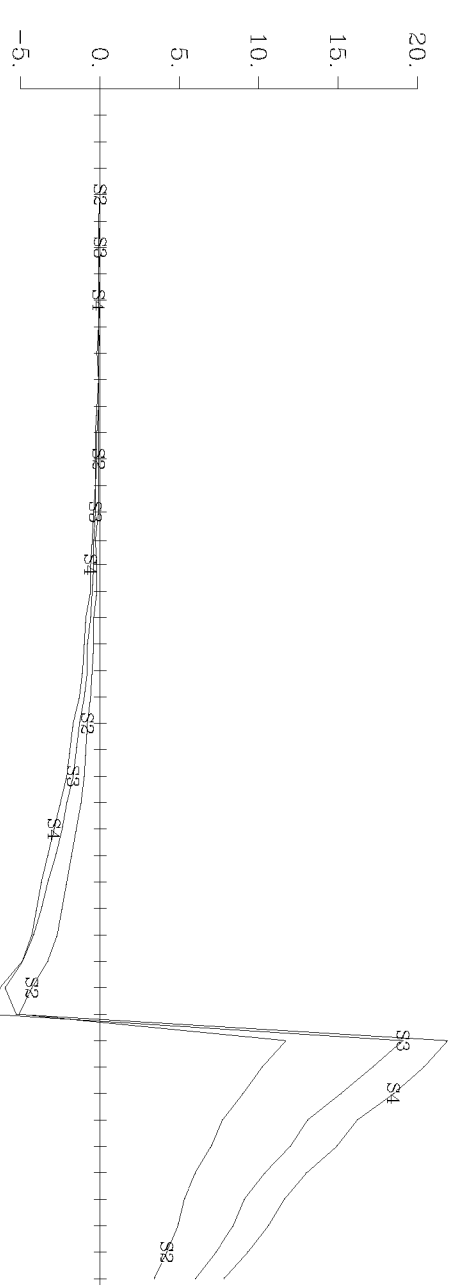

Pulse EM Off-time
 Channels 19-24
 (nT/sec)

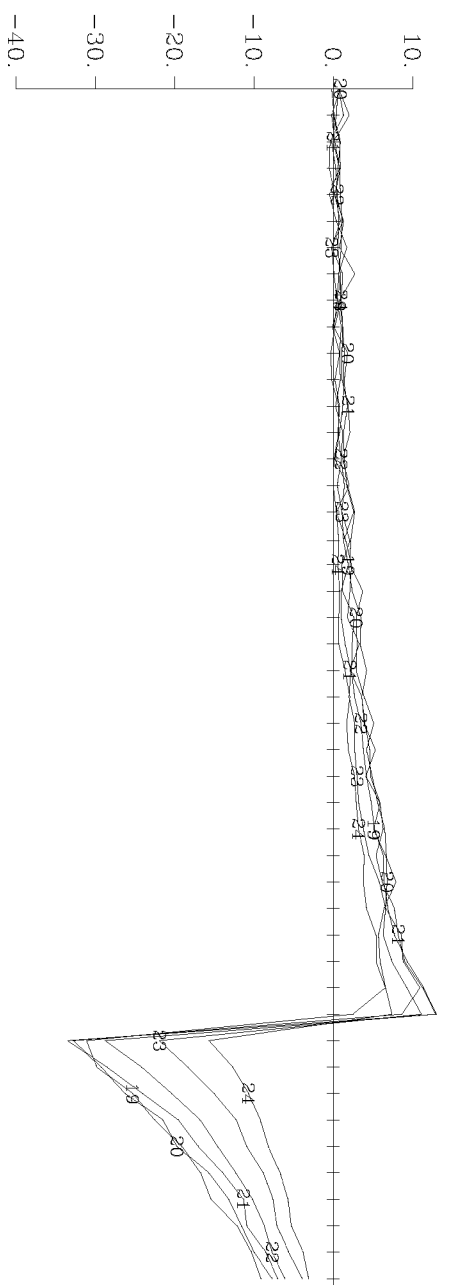

Urso Major Minerals Inc. Shakespeare East Property
 Loop 1, Hole U-03-120 X Component
 Crone Geophysics & Exploration Ltd.

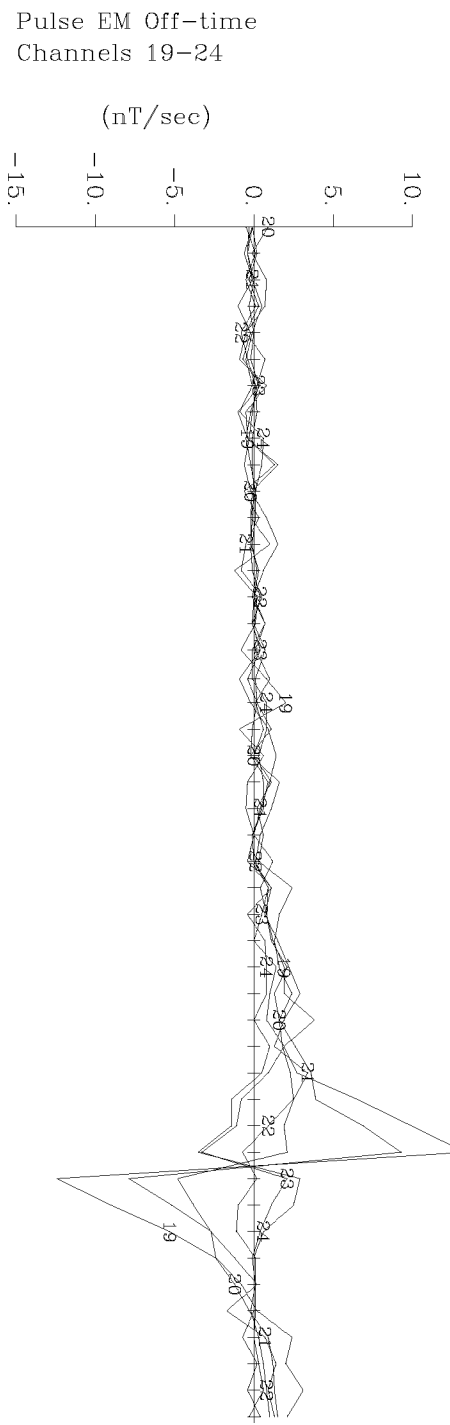
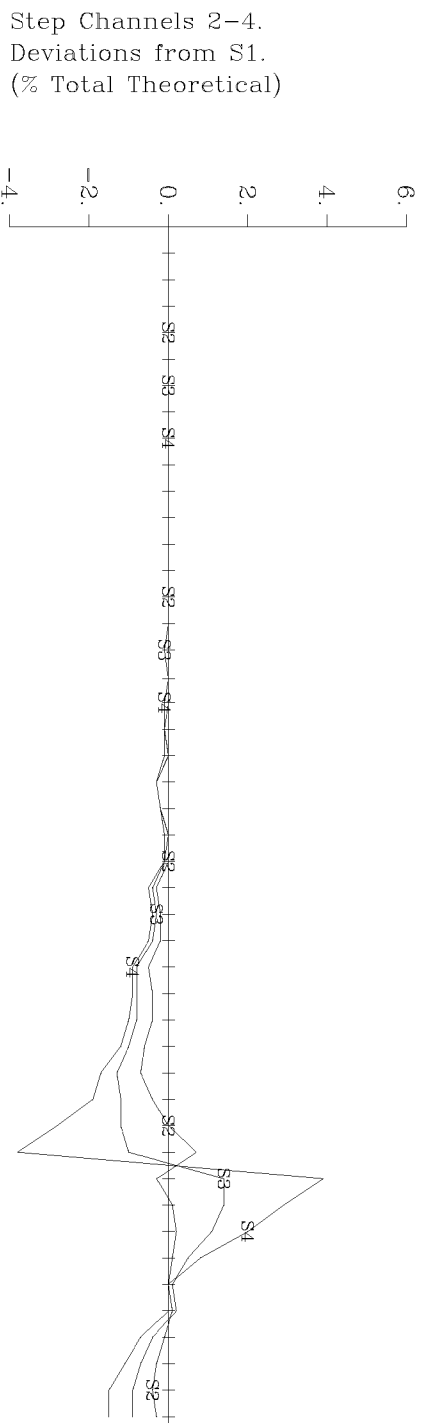
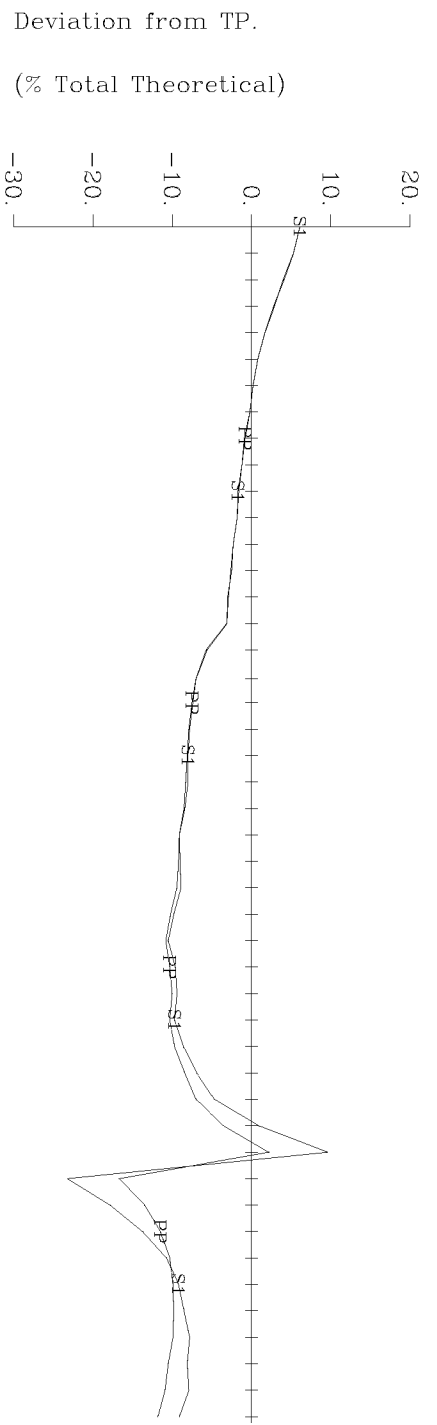
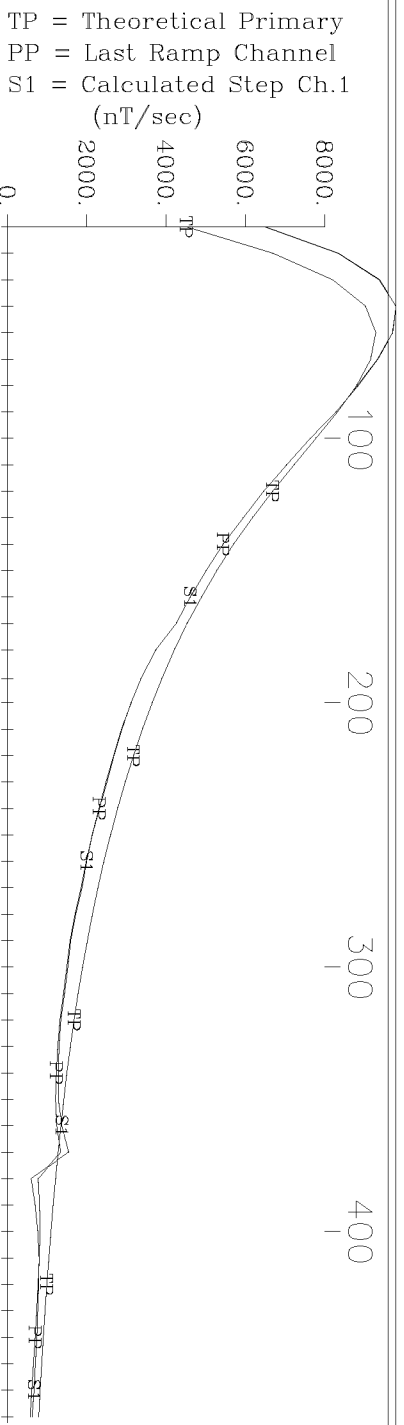

Urso Major Minerals Inc. Shakespeare East Property
 Loop 1, Hole U-03-120 Y Component
 Crone Geophysics & Exploration Ltd.

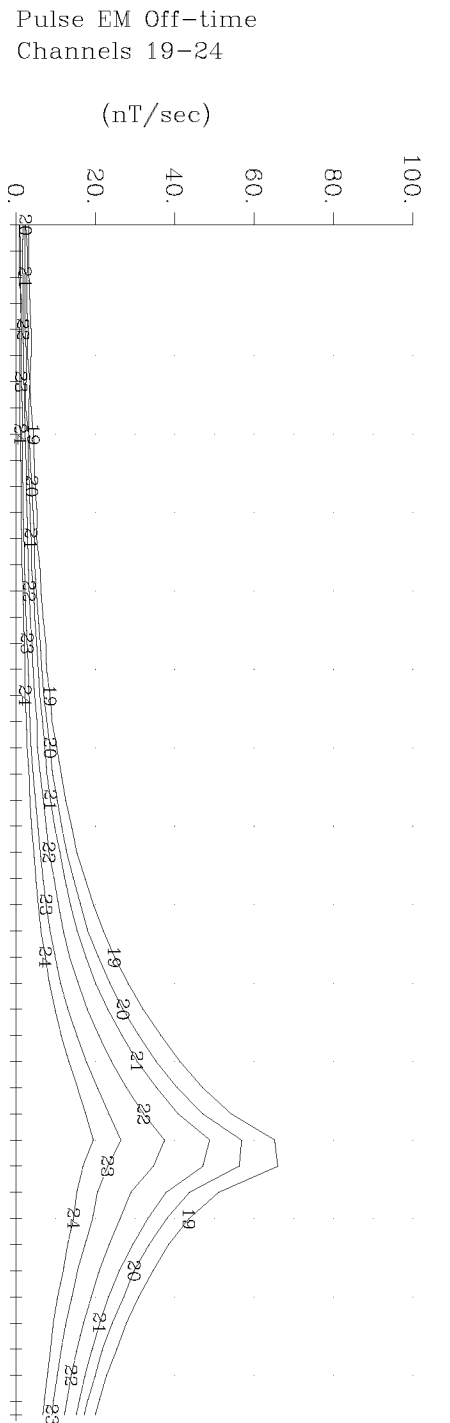
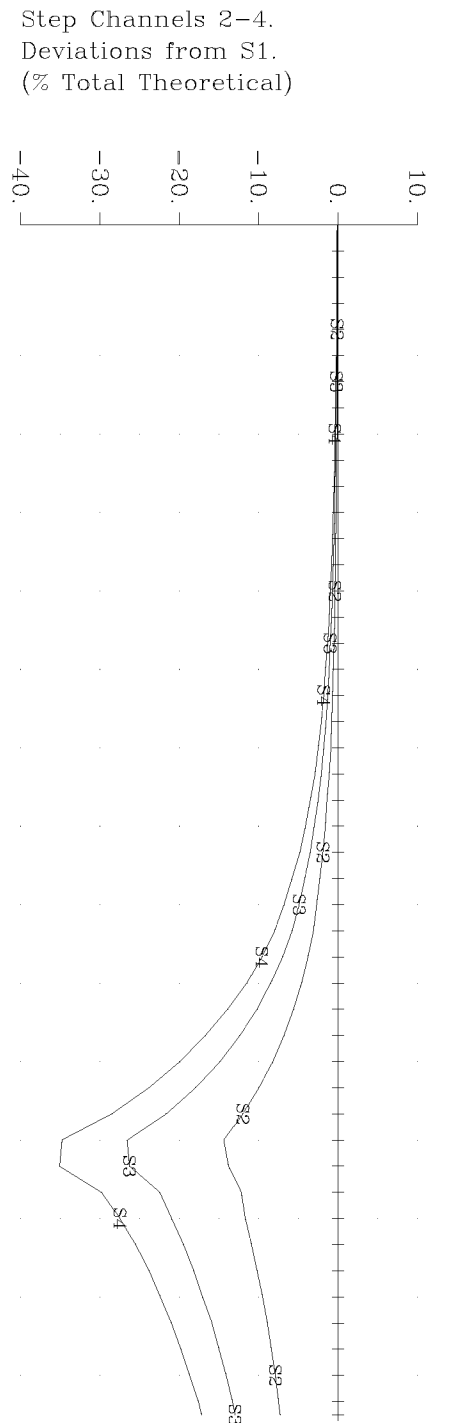
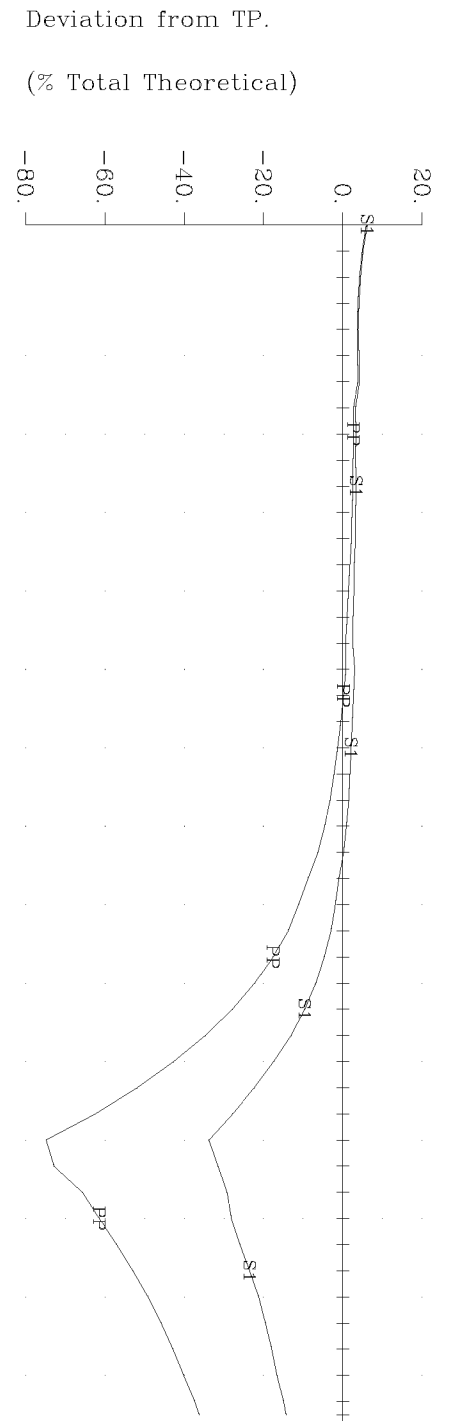
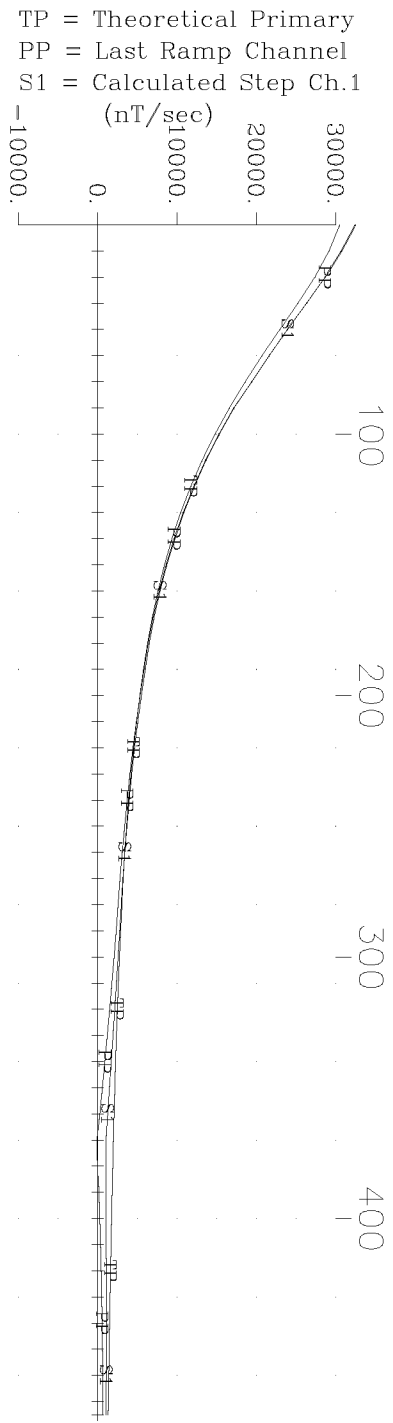

Ursa Major Minerals Inc. Shakespeare East Property
 Loop 1, Hole U-03-120 Z Component
 Crone Geophysics & Exploration Ltd.

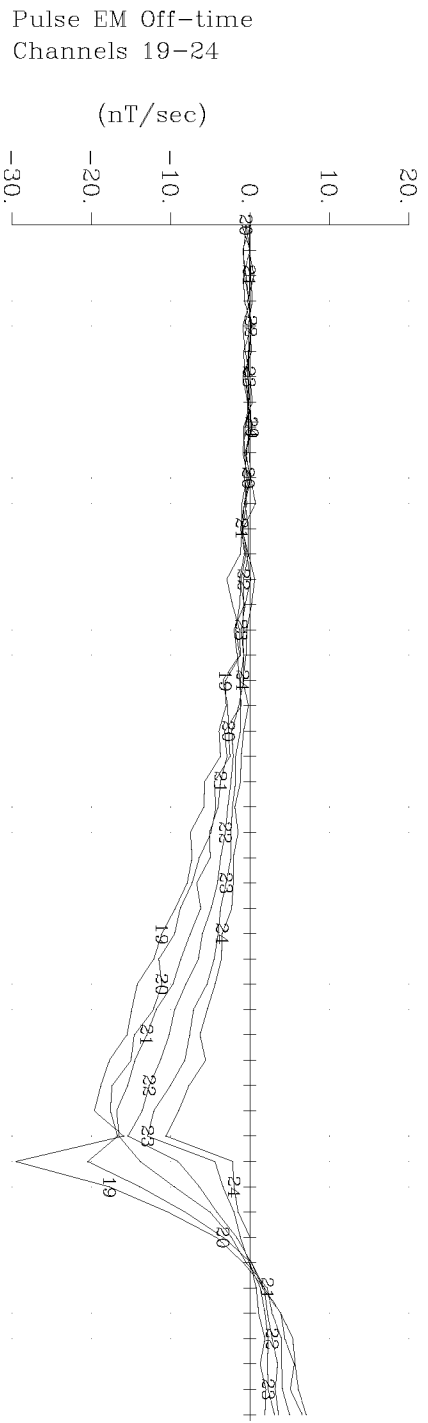
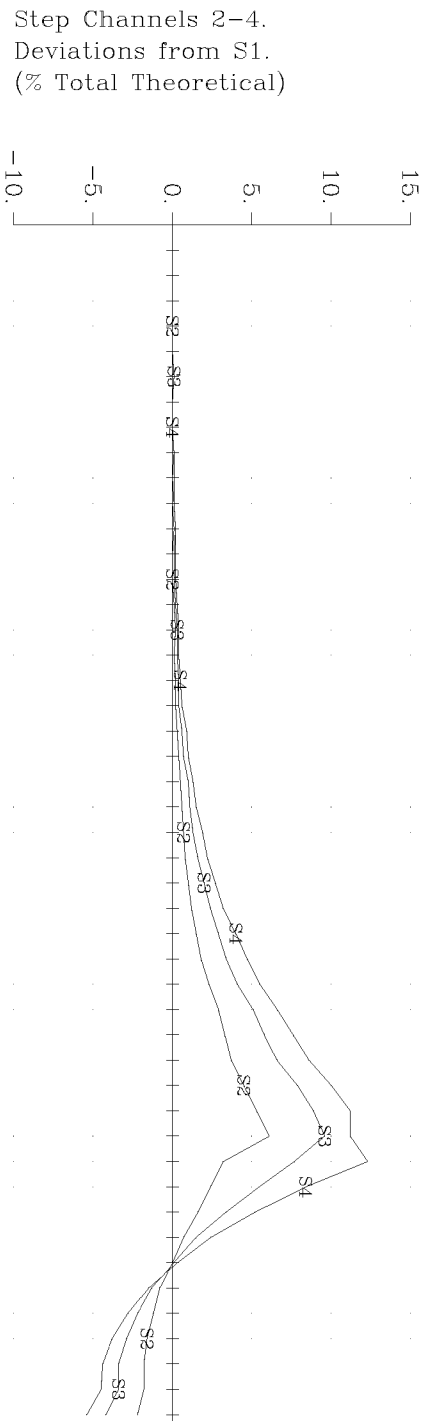
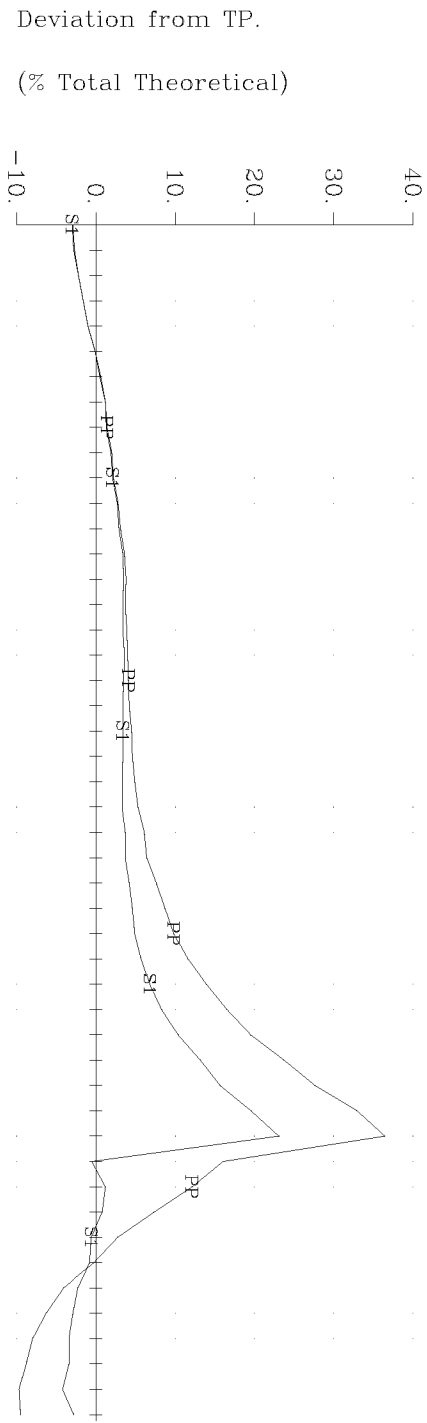
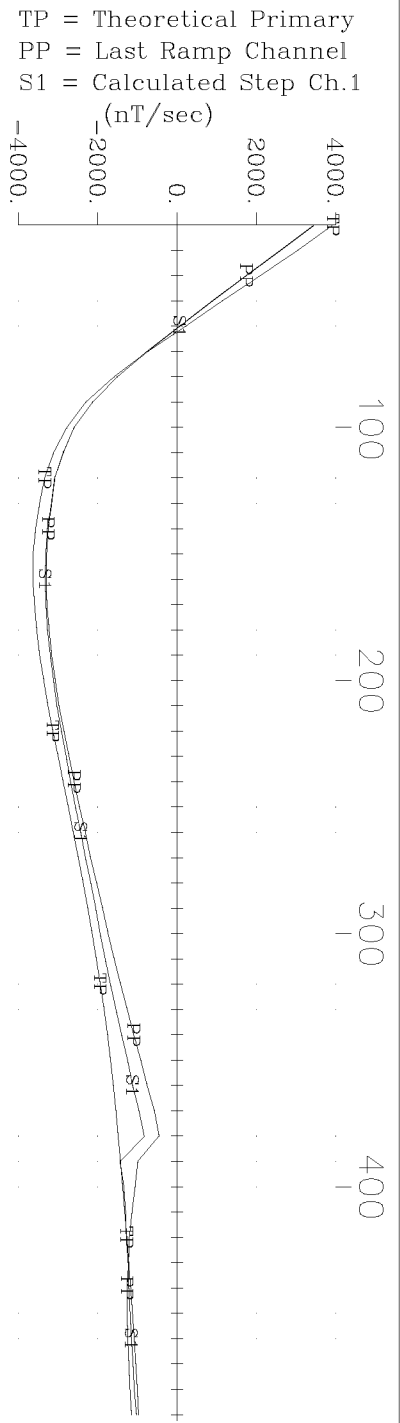

Ursa Major Minerals Inc. Shakespeare East Property
 Loop 2, Hole U-03-121 X Component
 Crone Geophysics & Exploration Ltd.

TP = Theoretical Primary
 PP = Last Ramp Channel
 S1 = Calculated Step Ch.1
 (nT/sec)

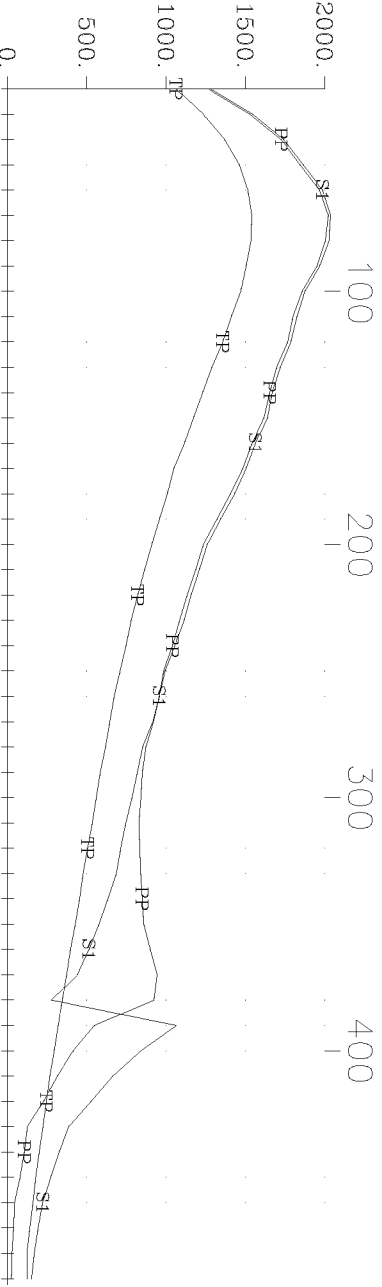

Deviation from TP.
 (% Total Theoretical)

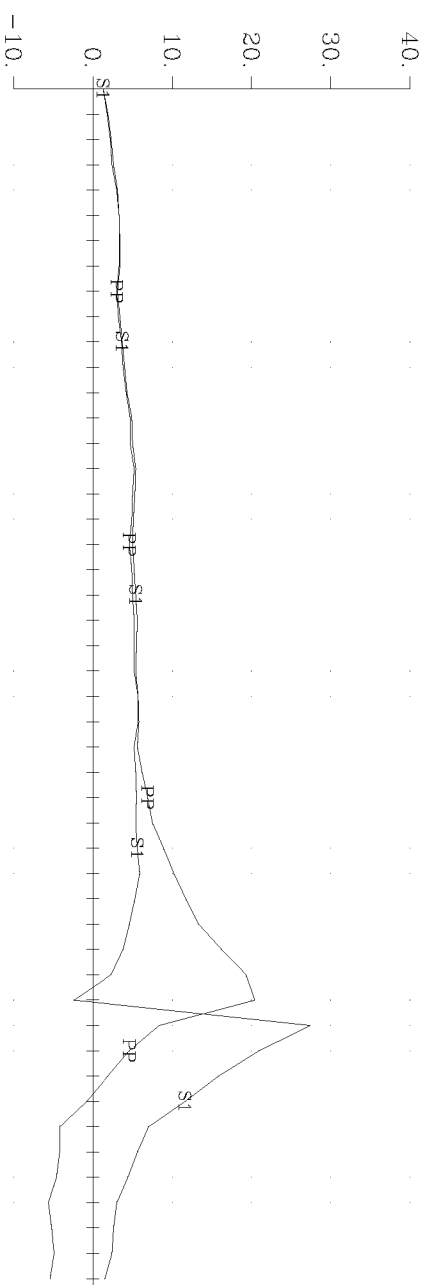

Step Channels 2-4.
 Deviations from S1.
 (% Total Theoretical)

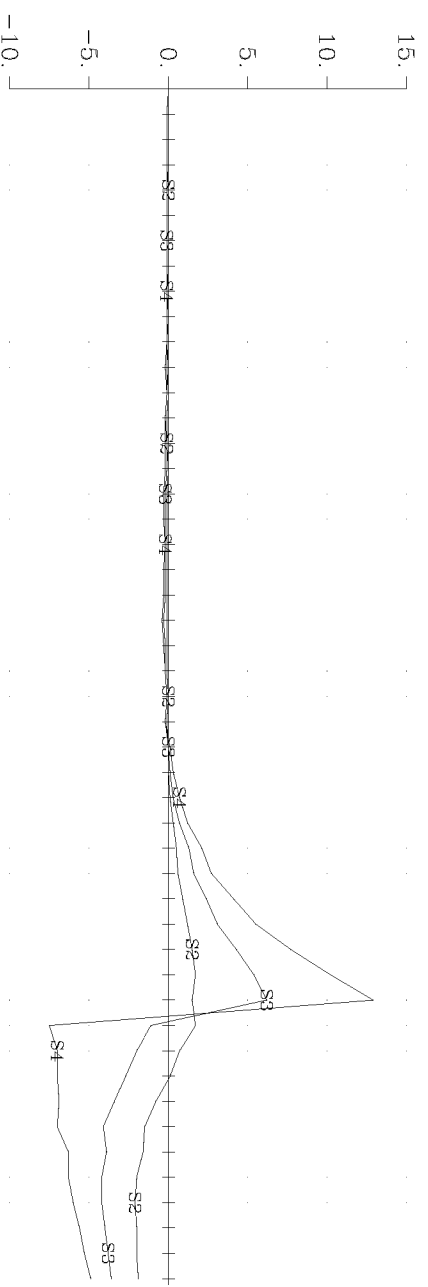

Pulse EM Off-time
 Channels 19-24
 (nT/sec)

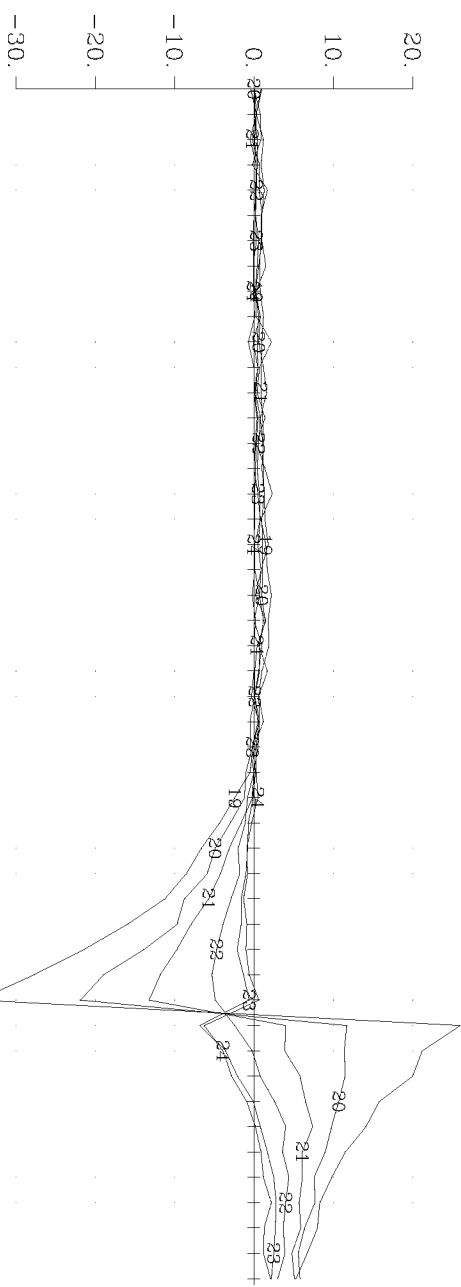

Ursa Major Minerals Inc. Shakespeare East Property
 Loop 2, Hole U-03-121 Y Component
 Crone Geophysics & Exploration Ltd.

TP = Theoretical Primary
 PP = Last Ramp Channel
 S1 = Calculated Step Ch.1

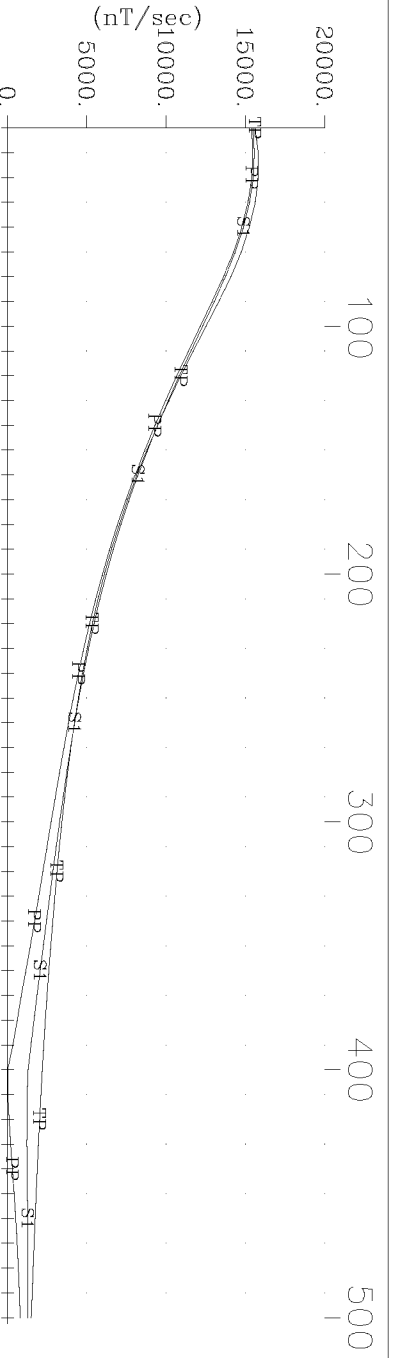

Deviation from TP.
 (% Total Theoretical)

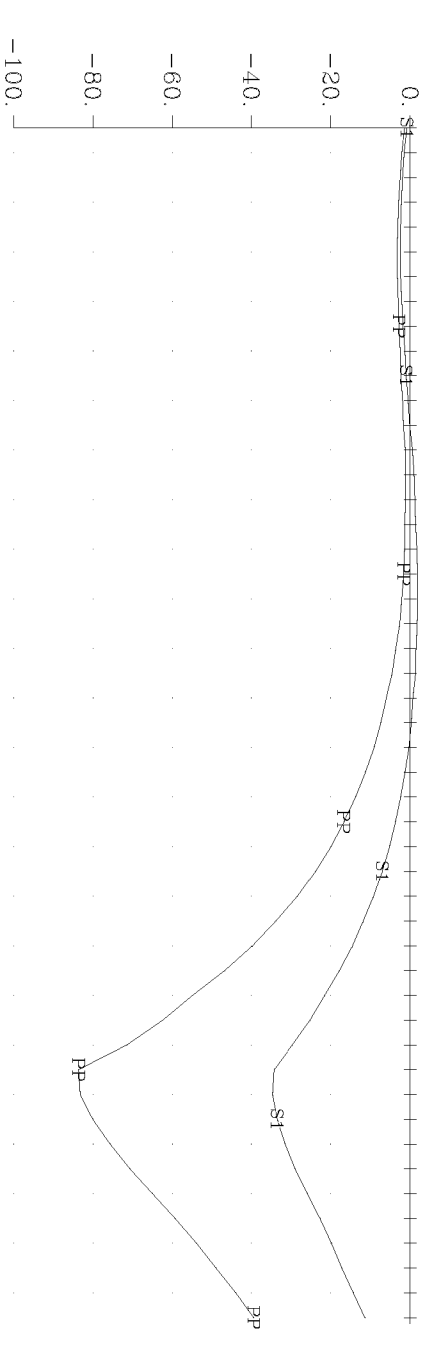

Step Channels 2-4.
 Deviations from S1.
 (% Total Theoretical)

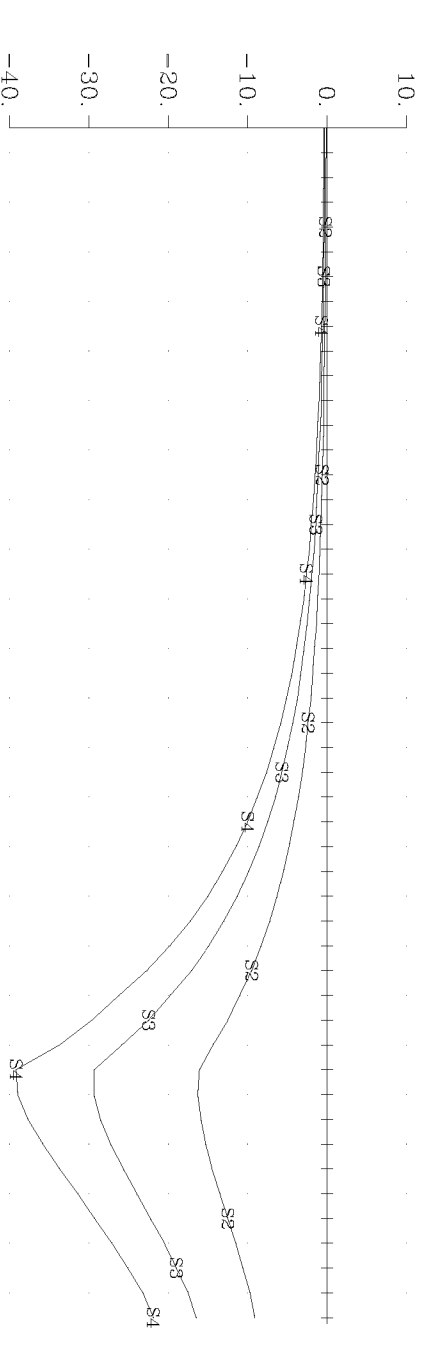

Pulse EM Off-time
 Channels 19-24
 (nT/sec)

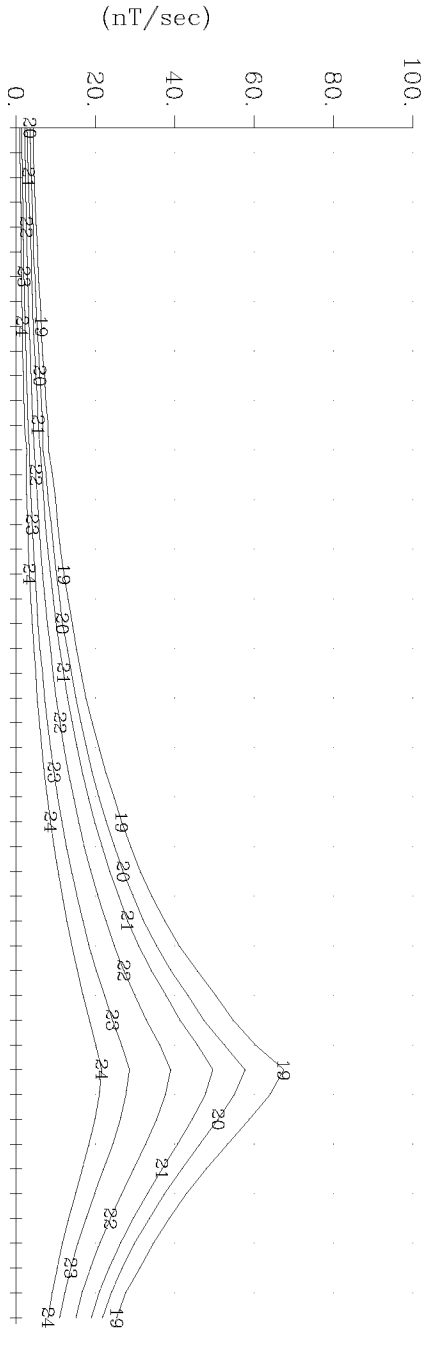

Ursa Major Minerals Inc. Shakespeare East Property
 Loop 2, Hole U-03-121 Z Component
 Crone Geophysics & Exploration Ltd.

APPENDIX V
CRONE INSTRUMENT SPECIFICATIONS



Crone Pulse EM System Description

SYSTEM DESCRIPTION

The Crone Pulse EM system is a time domain electromagnetic method (TDEM) that utilizes an alternating pulsed primary current with a controlled shut-off and measures the rate of decay of the induced secondary field across a series of time windows during the off-time. The system uses a transmit loop of any size or shape. A portable power source feeds a transmitter which provides a precise current waveform through the loop. The receiver apparatus is moved along surface lines or down boreholes.

The transmitter cycle consists of slowly increasing the current over a few milliseconds, a constant current, abrupt linear termination of the current, and finally zero current for a selected length of time in milliseconds. The EMF created by the shutting-off of the current induces eddy currents in nearby conductive material thus setting-up a secondary magnetic field. When the primary field is terminated, this magnetic field will decay with time. The amplitude of the secondary field and the decay rate are dependent on the quality and size of the conductor. The receiver, which is synchronized to the off-time of the transmitter, measures this transient magnetic field where it cuts the surface coil or borehole probe. These readings are across fixed time windows or "channels".

SYSTEM TERMINOLOGY

Ramp Time

"Ramp time" refers to the controlled shut-off of the transmitter current. Three ramp times are selectable by the operator; 0.5ms, 1.0ms, and 1.5ms. By controlling the shut-off rather than having it depend on the loop size and current ensures that the same waveform is maintained for different loops so data can be properly compared.

The 1.5ms ramp is the normally used setting for good conductors. It keeps the early channel responses on scale and decreases the chance of overload. The faster ramp times of 1.0ms and 0.5ms will enhance the early time responses. This can be useful for weak conductors when data from the higher end of the frequency spectrum is desired.

Time Base

Time base is the length of time the transmitter current is off (it includes the ramp time). This also equals the on time of the current. Time bases are available for both 60Hz and 50Hz noise rejection respectively:

- 8.33ms (30Hz), 16.66ms (15Hz), 50ms (5Hz), 100ms (2.5Hz), 150ms (1.67Hz), 300ms (0.833Hz), 500ms (0.5Hz), 750ms (0.33Hz), 1000ms (0.25Hz)
- 10ms (25Hz), 20ms (12.5Hz), 50ms (5Hz), 100ms (2.5Hz), 150ms (1.67Hz), 300ms (0.833Hz), 500ms (0.5Hz), 750ms (0.33Hz), 1000ms (0.25Hz)

Since readings are taken during the off cycles, the time base will have an effect on the receiver channels. Normally, a standard time base is selected for the type of system and survey being used, but this can be changed to suit a particular situation. A longer time base is preferred for conductors of greater time constants, and in surveys such as resistive soundings where more channels are desired.

Zero Time Set

The term "zero time set" or "ZTS" refers to the starting point for the receiver channel measurements. It is manually set on the receiver by the operator thus allowing adjustments for the ramp times and fine tuning for any fluctuations in the transmitter signal.

Receiver Channels

The rate of decay of the secondary field is measured across fixed time windows which occupy most of the off-time of the transmitter. These time windows are referred to as "channels". These channels are numbered in sequence with "1" being the earliest. The analog and datalogger receivers measured eight fixed channels. The digital receiver, being under software control, offers more flexibility in the channel positioning, channel width, and number of channels.

PP Channel

The PEM system monitors the primary field by taking a measurement during the current ramp and storing this information in a "PP channel". This means that data can be presented in either normalized or normalized formats, and additional information is available during interpretation. The PP channel data can provide useful diagnostic information and helps avoid critical errors in field polarity.

Synchronization

Since the PEM system measures the secondary field in the absence of the primary field, the receiver must be in "sync" with the transmitter to read during the off-time. There are three synchronization methods available: cable connection, radio telemetry, and crystal clock. This flexibility enhances the operational capabilities of the system.

SURVEY METHODS

The wide frequency spectrum of data produced by a Pulse EM survey can be used to provide structural geological information as well as the direct detection of conductive or conductive associated ore deposits. The various types of survey methods, from surface and borehole, have greatly improved the chances of success in deep exploration programs. There are eight basic profiling methods as well as a resistivity sounding mode.

Moving Coil

A small, multi-turn transmitter loop (13.7m diameter) is moved for each reading while the receiver remains a fixed distance away. This method is ideal for quick reconnaissance in areas of high background conductivity.

Moving Loop

Same as Moving Coil method, but with a larger rectangular transmit loop (100 to 300 meters). This method provides deeper penetration in areas of high background conductivity, and works best for near-vertical conductors. This method can be used in conjunction with the Moving In-loop survey for increased sensitivity to horizontal conductors.

Moving In-Loop

A rectangular transmit loop of size 100 to 300 meters is moved for each reading while the receiver remains at the center of the loop. This method provides deep penetration in areas of very high background conductivity, and works best for near-horizontal conductors. It can be used in conjunction with the Moving Loop survey.

Large In-Loop

A very large, stationary transmit loop (800m square or more) is used, and survey lines are run inside the loop. This mode provides very deep penetration (700m or more) and couples best with shallow dip conductors (<45 deg.) under the loop.

Deep EM

A large, stationary transmit loop is used, and survey lines are run outside the loop. This mode provides very deep penetration, and couples best with steeply dipping conductors (>45 deg.) outside the loop.

Borehole (Z Component only)

Isolated Borehole: A drill hole is surveyed by lowering a probe down a hole and surveying it with a number of transmit loops laid out on surface. The data from multiple loops gives directional information on the conductors.

Multiple Boreholes: One large transmit loop is used to survey a number of closely spaced holes. The change in anomaly from hole to hole provides directional information. These methods have detected conductors to depths of 2500m from surface and up to 200m from the hole.

3-D Borehole

Drill holes are surveyed with both the Z and the XY borehole probes. The X and Y components provide accurate direction information using just one transmit loop. Since the probe rotates as it moves down the hole a correction is required for the X-Y data. This is accomplished in one of two ways. The measurement of the primary field from the "PP" channel can be used to apply a "cleaning" algorithm to remove most of the secondary field contamination, and compare this to theoretical values. The amount of probe rotation is then calculated, and the correction can be made. The second method involves the use of an optional orientation tool for the X-Y probe. This attachment uses dip meters to calculate the probe rotation. A third method uses another rotation tool with integrated 3-axis accelerometers and 3-axis magnetometers which can be used to correct rotation on steeply dipping holes including vertical.

Underground Borehole

Underground drill holes can be surveyed in any of the above mentioned borehole methods with one or more transmit loops on the surface. Near-horizontal holes can be surveyed using a push-rod system.

Resistivity Soundings

By reading a large number of channels in the centre of a transmit loop it is possible to perform a decay curve analysis giving a best-fit layer earth model using programs such as ARRTI or TEMIX.

EQUIPMENT

Transmit Loops

The PEM system can operate with practically any size of transmit loop, from a multi-turn circular loop 13.7m in diameter, to a 1 or 2 turn loop of any shape up to 1 or 2 kilometers square using standard insulated copper wire of 10 or 12 gauge. The multi-turn loop is made in two sections with screw connectors. The 10 or 12 gauge loop wire comes on spools in either 300m or 400m lengths. The spools can be mounted on pack frame wire winders for laying out or retrieving.

Power Supply

The PEM system has been produced in 2 varieties: high power (4.8 KW), and low power (2.4 KW). The low power PEM system normally operates with an input voltage from 24V to 240V with a maximum output current of 20 amps. For very low power surveys a 20amp/hr 24V battery can be used. The high power system operates on a continuously variable voltage input up to 240V with a maximum output current of 30 amps. The power supply requires a motor generator and a voltage regulator to control and filter the input voltage to the transmitter.

Specifications: PEM Motor Generator

- (2.4 KW) 4.5 hp Robin EH34 engine, 120V 3-phase alternator
- (4.8 KW) 11 hp Robin RGV6100 240V/120V generator (1-phase)
- cable output to regulator
- fuse type overload protection
- steel frame
- external gas tank

- optional packframe for low-power generator
- wooden shipping box
- unit weight: 33kg (2.4 KW); 81kg (4.8 KW)
- shipping weight: 47kg (2.4 KW); 100kg (4.8 KW)

Specifications: PEM Variable Voltage Regulator

- High Power
 - Continuously variable voltage output up to 240V
 - 30 amp maximum current
 - Integrated sealed aluminum case ruggedized for shipping
 - Shipping weight 18kg
- Low Power
 - selectable voltage between 24v and 120v
 - 20amp maximum current
 - anodized aluminum case
 - padded wooden shipping box
 - unit weight 10kg; shipping weight 18kg
- fuse and internal circuit breaker protection
- cable connections to motor generator and transmitter

Specifications: PEM Transmitter

- High Power
 - Timebases
 - ♦ 8.33ms (30Hz), 10ms (25Hz), 16.66ms (15Hz), 20ms, (12.5Hz), 50ms (5Hz), 100ms (2.5Hz), 150ms (1.67Hz), 300ms (0.833Hz), 500ms (0.5Hz), 750ms (0.33Hz), 1000ms (0.25Hz)
 - ramp times: 0.5ms, 1.0ms, 1.5ms
 - operating voltage: continuously variable input up to 240V
 - output current up to 30amp maximum
 - optional current control feedback system features constant current output with ± 0.1 amp precision
 - integrated sealed aluminum case ruggedized for shipping with shock protection
- Low Power
 - Timebases
 - ♦ 8.33ms (30Hz), 10ms (25Hz), 16.66ms (15Hz), 20ms, (12.5Hz), 50ms (5Hz), 100ms (2.5Hz), 150ms (1.67Hz), 300ms (0.833Hz)
 - operating voltage: 24v to 120v
 - output current: 5amp to 20amp
 - anodized aluminum case
 - optional pack frame
 - unit weight 12.5kg; shipping weight 22kg
 - padded wooden shipping box
- monitors for input voltage, output current, shut-off ramp, tx loop continuity, instrument temperature, and overload output current
- automatic shut-off for open loop, high instrument temperature, and overload
- fuse and circuit breaker overload protection
- three sync modes:
 - built-in radio and antenna
 - cable sync output for direct wire link to receiver or remote radio
 - crystal clock connection with built-in optical isolation

Receiver

The receiver measures the rate of decay of the secondary field across several time channels. The Crone Digital Receiver, in use since 1987 uses software control, offering a variety of programmable channel configurations.

Specifications: Digital PEM Receiver

- 26 bit (156dB) dynamic range
- operating temperature -40°C to 50°C
- built-in non-volatile memory
- optional pack frame
- unit weight 15kg; shipping weight 25.5kg
- padded wooden shipping box
- Menu driven operating software system offering the following functions:
 - controls channel positions, channel widths, and number of channels
 - Timebases: 8.33ms (30Hz), 10ms (25Hz), 16.66ms (15Hz), 20ms (12.5Hz), 50ms (5Hz), 100ms (2.5Hz), 150ms (1.67Hz), 300ms (0.833Hz), 500ms (0.5Hz), 750ms (0.33Hz), 1000ms (0.25Hz)
 - ramp time selectable
 - sample stacking from 1 to 65536
 - automatic gain and spike rejection
 - scrolling routines for viewing data
 - graphic display of decay curve and profile with various plotting options
 - routines for memory management
 - control of data transmission
 - provides information on instrument and operating status

Sync Equipment

There are three modes of synchronization available; radio, cable, and crystal clock. The radio sync signal can be transmitted through a booster antenna from either the PEM Transmitter internal radio or through a Remote Radio.

Specifications: Sync Cable

- 2 conductor, 24awg, Teflon coated
- approx. 900m per aluminum spool with connectors

Specifications: Remote Radio

- operating frequency 27.12mhz
- 12V rechargeable gel cell battery supply
- fuse protection
- sync wire link to transmitter
- coaxial link to booster antenna
- anodized aluminum case
- unit weight 2.7kg

Specifications: Booster Antenna

- 8m, 4 section aluminum mast
- guide rope support
- ¼ wave CB fiberglass antenna
- range up to 2km
- coaxial connection to transmitter or remote radio

Specification: Crystal Clocks

- heat stabilized crystals
- 24V rechargeable gel cell battery supply

- anodized aluminum case
- rx unit can be separate or housed in the receiver
- outlet for external supplementary battery supply

Surface PEM Receive Coil

The Surface PEM Receive Coil picks up the EM field to be measured by the receiver. The coil is mounted on a tripod that can be positioned to take readings of any component of the field.

Specifications: Surface PEM Receive Coil

- ferrite core antenna
- VLF filter
- 10khz bandwidth
- two 9v transistor battery supply
- tripod adjustable to all planes
- unit weight 4.5kg; shipping weight 13.5kg
- padded wooden shipping box

Surface SQUID sensor

CSIRO 1-, 2- or 3- axis high-sensitivity superconducting sensor measures magnetic field in the sub-pT range.

Specifications: Surface SQUID sensor

- liquid nitrogen cooled, 12 hour operation between reservoir refills
- low-noise floor $\sim 350\text{fT}/\sqrt{\text{Hz}}$
- man-portable sensor and control system
- moving loop, or large loop survey configuration
- solid teflon non-magnetic housing
- operational temperature range: -40°C to 40°C
- total system packaged shipping weight (without liquid nitrogen): 62kg

Borehole PEM Z Component Probe

The Z component probe measures the axial component of the EM field. The Z component data is not affected by probe rotation so no correction is required.

Specifications: Borehole PEM Z Component Probe

- ferrite core
- dimensions: length - 1.6m; dia - 3.02cm (3.15cm for high pressure tested probes)
- internal rechargeable NiCd battery supply
- replaceable heat shrink tubing for abrasion protection
- pressure tested for depths 1300m, 2000m, and 2800m
- packaged in padded cover and aluminum tube
- shipped in padded wooden box; total weight 17kg

Borehole PEM XY Component Probe

The XY probe measures two orthogonal components of the EM field perpendicular to the axis of the hole. Correction for probe rotation can be achieved by mathematical theoretical primary field reduction or more commonly with an attached orientation tool sensor.

Specifications: Borehole PEM XY Component Probe

- ferrite core
- dimensions: length - 2.01m; dia - 3.02cm
- internal rechargeable ni-cad battery supply

- selection of X or Y coils by means of a switch box on surface or automatic switching with Digital receiver
- replaceable heat shrink tubing for abrasion protection
- pressure tested for depths to 2800m
- packaged in padded cover and aluminum tube
- shipped in padded wooden box; total shipping weight 20kg

Specifications: Orientation Tool

- 2 axis tilt sensors
- accuracy ± 0.1 deg.
- operating range -88 to -10 deg.
- dimensions: length - 0.94m; dia - 28.5mm
- packaged in padded cover and aluminum tube
- shipped in padded wooden box; total shipping weight 14kg

Specifications: Rotation Angle Direction (RAD) Tool

- integrated 3-axis accelerometers and 3-axis magnetometers
- dip and roll accuracy: $\pm 0.5^\circ$, azimuth accuracy: $\pm 1.0^\circ$
- operating range: all
- simultaneous 3D magnetometer borehole survey by station
- optional continuous logging mode
- dual 3-axis sensors provide an alternative complete borehole Dip-Azimuth measurement
- dimensions: length - 0.75m; dia - 31.8mm
- packaged in padded cover and aluminum tube
- shipped in padded wooden box; total shipping weight 14kg
- NiCd battery provides all-day operation
 - ♦ Length - 0.93m; dia - 28.6mm
 - ♦ Packaged in padded cover and aluminum tube
 - ♦ Shipped in padded wooden box; total shipping weight 14kg

Borehole Equipment

To lower the probe down a drill hole requires a cable and spool, winch assembly frame and cable counter. Borehole surveys also require equipment to "dummy probe" the hole before doing the survey.

Specifications: Borehole Cable

- two conductor shielded cable
- kevlar strengthened
- lengths are available up to 2600m on three sizes of spools
- shipped in wooden box

Specifications: Slip Ring

- attaches to side of borehole cable spool providing a connection to the receiver while allowing the spool to turn.
- VLF filter
- pure silver contacts

Specifications: Borehole Winch Frame

- welded aluminum frame
- removable axle
- chain driven, 3 speed gear box
- hand or optional power winding
- hand brake and lock

- optional chain-gear safety cover
- two sizes: standard for up to 1300m cable; large for longer cables
- shipped in wooden box

Specifications: Borehole Counter

- attaches to the drill hole casing
- calibrated in meters
- shipped in wooden box; total weight 13kg

Specifications: Dummy Probe and Cable

- solid steel or steel pipe
- same dimensions as borehole probe
- shear pin connection to dummy cable
- steel dummy cable on aluminum spool
- cable mounts on borehole frame
- various lengths to 2600m on 3 spool sizes.

URSA Major Minerals Incorporated

Crone Geophysics Borehole Geophysics Drillhole Distribution June 2011

Prepared By: Harold Tracanelli, Getn, P.Ge; Agent URSA Major Minerals Incorporated

Monday January 09th., 2012

	Meters On	Dollar Value on	Geo Design	Meters On	Dollar Value on	Geo Design	Meters On	Dollar Value on	Geo Design	Meters On	Dollar Value on	Geo Design	Depth in Hole Surveved
<u>DDH</u>	<u>S-1203118</u>	<u>S-1203118</u>	<u>Support</u>	<u>S-1247350</u>	<u>S-1247350</u>	<u>Support</u>	<u>S-36045</u>	<u>S-36045</u>	<u>Support</u>	<u>S-36406</u>	<u>S-36406</u>	<u>Support</u>	
U-08-02	305	5130.1	169.58	405	6812.1	225.18							710
U-03-118	227	3818.14	126.212				389	6542.98	216.284				340
U-03-116	74	1244.68	41.144				546	9183.72	303.576				350
U-03-114	126	2119.32	70.056				224	3767.68	124.544				620
U-03-113							340	5718.8	189.04				616
U-03-120							249.35	4194.067	138.6386	220	3700.4	122.32	470
U-03-121	<u>0</u>	<u>0</u>	<u>0</u>	<u>0</u>	<u>0</u>	<u>0</u>	<u>0</u>	<u>0</u>	<u>0</u>	<u>490</u>	<u>8241.8</u>	<u>272.44</u>	<u>490</u>
	732	12312.24	406.992	405	6812.1	225.18	1748.35	29407.25	972.0826	710	11942.2	394.76	3596

Value of Work Performed On:

	<u>Actual</u>	<u>Rounded</u>
S-1203118	12719.232	12719
S-1247350	7037.28	7037
S-36045	30379.3296	30379
S-36046	<u>12336.96</u>	<u>12337</u>
	62472.8016	62472

Crone Geophysics and Exploration Ltd; borehole geophysics - average survey unit cost =

\$16.82 per meter.

Project design and geological - exploration - technical support =

\$0.56 per meter.

Borehole Geometry
Hole xy118
Crone Geophysics & Exploration Ltd.

Declination -9°
Inclination 0°
Total Field 0 nT

- hole az
- hole dip
- tool az
- tool dip

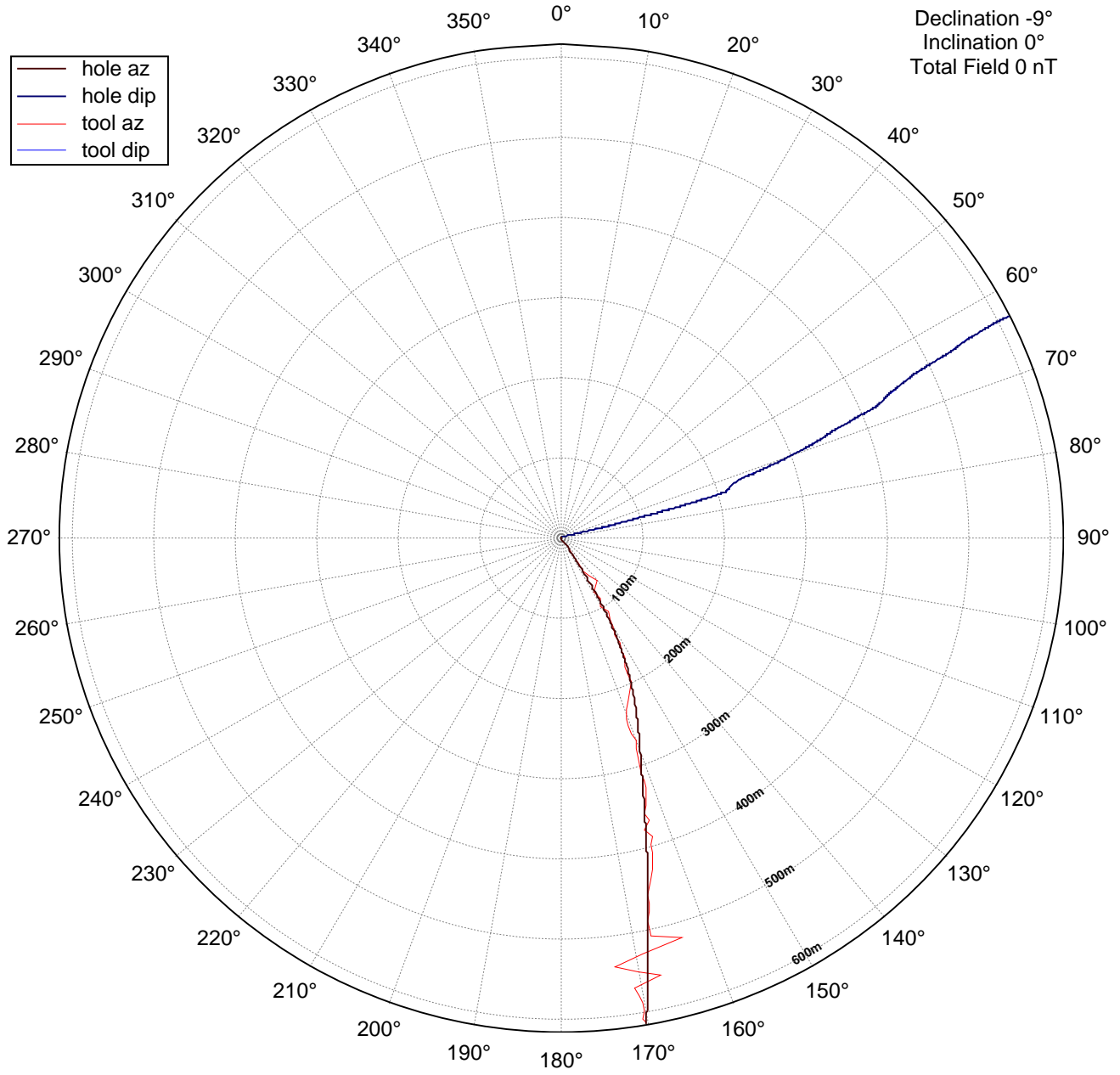

Borehole Geometry
Hole xy118
Crone Geophysics & Exploration Ltd.

Declination -9°
Inclination 0°
Total Field 0 nT

- hole az
- hole dip
- tool az
- tool dip

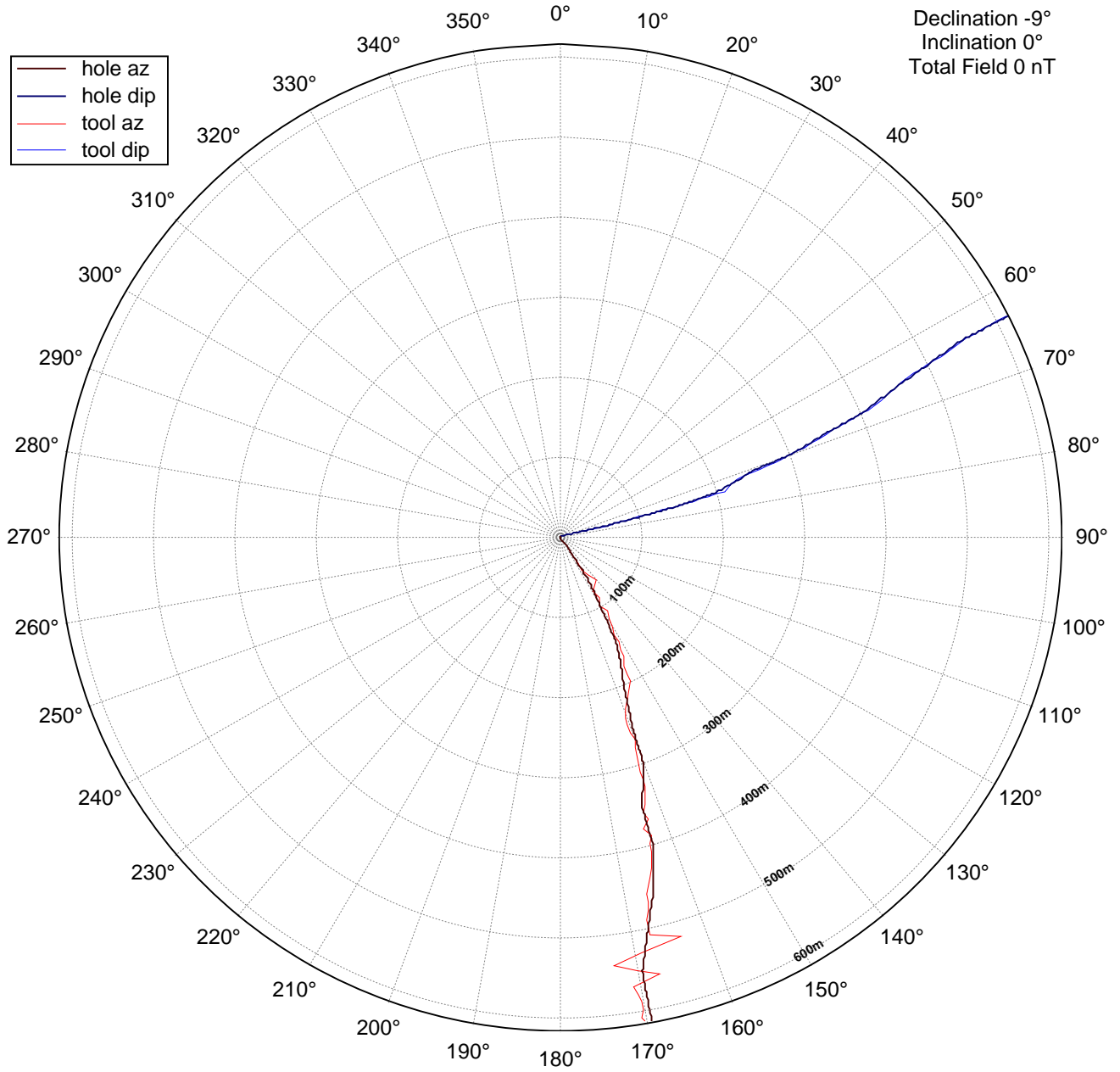

Date / Time of Issue: Thu Jan 05 16:37:12 EST 2012
TOWNSHIP / AREA PLAN
SHAKESPEARE G-3001
ADMINISTRATIVE DISTRICTS / DIVISIONS
 Mining Division Sudbury
 Land Titles/Registry Division SUDBURY
 Ministry of Natural Resources District SUDBURY

TOPOGRAPHIC

	Administrative Boundary		Freehold Patent
	Township		Surface Ancestral Rights
	Cadastral Lot		Surface Rights Only
	Provincial Park		Mining Rights Only
	Indian Reserve		Leasehold Patent
	Oil Pipeline		Surface Ancestral Rights
	Conduit		Surface Rights Only
	Mine Shaft		Mining Rights Only
	Mine Headframe		Leasehold Patent
	Turbine		Leasehold Patent
	Road		Surface Ancestral Rights
	Fence		Surface Rights Only
	Natural Gas Pipeline		Mining Rights Only
	Utility		Leasehold Patent
	Forest		Crown Grant (Old open for Sale)
			Mining Claim
			Gold Only Mining Claim

LAND TENURE WITHDRAWALS

<input type="checkbox"/>	1218	Access Withdrawal from Designation
<input type="checkbox"/>	1219	Mining Act Withdrawal of Rights
<input type="checkbox"/>	1220	Surface and Mining Rights Withdrawal
<input type="checkbox"/>	1221	Surface Rights Only Withdrawal
<input type="checkbox"/>	1222	Mining Rights Only Withdrawal
<input type="checkbox"/>	1223	Gold Only Mining Claim Withdrawal
<input type="checkbox"/>	1224	Surface Rights Only Withdrawal
<input type="checkbox"/>	1225	Mining Rights Only Withdrawal
<input type="checkbox"/>	1226	Gold Only Mining Claim Withdrawal
<input type="checkbox"/>	1227	Surface Rights Only Withdrawal
<input type="checkbox"/>	1228	Mining Rights Only Withdrawal
<input type="checkbox"/>	1229	Gold Only Mining Claim Withdrawal
<input type="checkbox"/>	1230	Surface Rights Only Withdrawal
<input type="checkbox"/>	1231	Mining Rights Only Withdrawal
<input type="checkbox"/>	1232	Gold Only Mining Claim Withdrawal
<input type="checkbox"/>	1233	Surface Rights Only Withdrawal
<input type="checkbox"/>	1234	Mining Rights Only Withdrawal
<input type="checkbox"/>	1235	Gold Only Mining Claim Withdrawal
<input type="checkbox"/>	1236	Surface Rights Only Withdrawal
<input type="checkbox"/>	1237	Mining Rights Only Withdrawal
<input type="checkbox"/>	1238	Gold Only Mining Claim Withdrawal
<input type="checkbox"/>	1239	Surface Rights Only Withdrawal
<input type="checkbox"/>	1240	Mining Rights Only Withdrawal
<input type="checkbox"/>	1241	Gold Only Mining Claim Withdrawal
<input type="checkbox"/>	1242	Surface Rights Only Withdrawal
<input type="checkbox"/>	1243	Mining Rights Only Withdrawal
<input type="checkbox"/>	1244	Gold Only Mining Claim Withdrawal
<input type="checkbox"/>	1245	Surface Rights Only Withdrawal
<input type="checkbox"/>	1246	Mining Rights Only Withdrawal
<input type="checkbox"/>	1247	Gold Only Mining Claim Withdrawal
<input type="checkbox"/>	1248	Surface Rights Only Withdrawal
<input type="checkbox"/>	1249	Mining Rights Only Withdrawal
<input type="checkbox"/>	1250	Gold Only Mining Claim Withdrawal

IMPORTANT NOTICES



LAND TENURE WITHDRAWAL DESCRIPTIONS

Number	Type	Date	Description
7423	Withdrawal	Jan 1, 2012	INFLA 191124/191125/191126/191127/191128/191129

1 DIVISION @ 1:2500 = 5.05 M²

DRAWING PREPARED BY:
 HAROLD TRACANELLI, GETUP GEO
 JANUARY 05TH 2012

H. Tracanelli P. Geo

LIRSA
 CRONE BOREHOLE GEOPHYSICS
 JUNE 2011 LOCATION MAP.

