

We are committed to providing [accessible customer service](#).

If you need accessible formats or communications supports, please [contact us](#).

Nous tenons à améliorer [l'accessibilité des services à la clientèle](#).

Si vous avez besoin de formats accessibles ou d'aide à la communication, veuillez [nous contacter](#).

2019 INDUCED POLARIZATION / MAGNETOMETER GEOPHYSICAL SURVEY: HEENAN BLOCK, MALLARD GOLD PROPERTY

HEENAN AND BENTON TOWNSHIPS
PORCUPINE MINING DIVISION, ONTARIO, CANADA

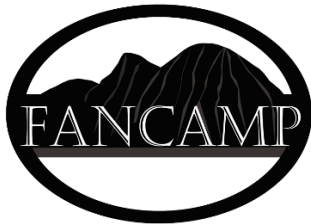

FANCAMP EXPLORATION LTD.
340 VICTORIA AVE.
WESTMOUNT, QUEBEC
H3Z 2M8

March 24th, 2020

Prepared By:

JOERG M. KLEINBOECK, P.GEO.

TABLE OF CONTENTS

EXECUTIVE SUMMARY	2
1.0 INTRODUCTION	3
2.0 PROPERTY DETAILS	3
2.1 Location and Access	3
2.2 Topography and Vegetation	4
2.3 Claims	4
3.0 PREVIOUS WORK	6
4.0 GEOLOGY	7
4.1 Property Geology	7
5.0 2019 GEOPHYSICAL PROGRAM	9
5.1 Methods – Induced Polarization	9
5.2 Methods – Magnetometer	11
5.3 Results	11
6.0 CONCLUSIONS AND RECOMMENDATIONS	12
7.0 REFERENCES	13

LIST OF FIGURES

Figure 1: General Location of the Heenan Block, Mallard Gold Property, Ontario.	4
Figure 2: Tenure of the Heenan Block, Mallard Gold Property.	7
Figure 3: Property Geology (after OGS P2067).	9

LIST OF TABLES

Table 1: Claim Details of the Heenan Block, Mallard Gold Property	5
-------------------------------------------------------------------------	---

LIST OF APPENDICES

Appendix I Statement of Qualifications	
Appendix II Maps	

EXECUTIVE SUMMARY

Fancamp Exploration Ltd. requested the author to complete a technical report for assessment purposes on a recently completed Induced Polarization and magnetometer geophysical survey that was completed on the Heenan Block located in Heenan and Benton Townships, Ontario. The Heenan Block is an outlier and part of a larger group of claims known as the Mallard Gold Property.

The Property is situated approximately 175 km northwest of Sudbury, Ontario and approximately 120 km southwest of Timmins, Ontario. The Property is located in Heenan and Benton Townships, and is bounded by UTM coordinates 395,115 E to 397,925 E, and 5,290,200 N to 5,292,145 N (NAD83, Z17N), and is covered by National Topographic System (NTS) map sheet 041O16 and 041O09. The Property consists of 26 unpatented mining claims, covering an area of approximately 390 ha.

The claims were originally staked upon the suggestion of the author to cover the folded and faulted contact of the Woman River Iron Formation and underlying felsic volcanic rocks. A reconnaissance geochemical program completed in 2018 by Fancamp Exploration Ltd. returned anomalous gold values, and thus a more detailed geochemical and prospecting program was completed in the summer of 2019.

In the fall of 2019, Fancamp Exploration Ltd. completed 7.1 km of line cutting, 6.4 km of induced polarization geophysical surveying, and 7.1 km of magnetometer geophysical surveying on the Heenan Block. This report describes the technical aspects of the surveys and subsequent results, and makes recommendations for additional exploration programs on the Property.

1.0 INTRODUCTION

In the fall of 2019, Fancamp Exploration Ltd. (“Fancamp”) completed 7.1 km of line cutting, 6.4 km of Induced Polarization (“IP”) and 7.1 km of magnetometer geophysical surveying. Line cutting was completed from October 28th through to November 5th, and geophysical surveying was completed between November 9th through to November 17th.

The work program focused over a portion of the Woman River Iron Formation and underlying felsic volcanic rocks where a reconnaissance geochemical program completed in 2018 by Fancamp returned anomalous gold values. Fancamp completed detailed geochemical and prospecting programs over the area in July and August of 2019, and upon receiving favourable results, decided to proceed with a line cutting and geophysical program over the target area. Highlights from programs returned geochemical values (B-horizon) that ranged from <5ppb to 1,000 ppb Au, and grab samples that ranged from <5 ppb to 418 ppb Au. There is no evidence of any historical diamond drilling in the assessment files over this target.

This report describes the technical aspects of the surveys and subsequent results, and makes recommendations for additional exploration programs on the Property.

2.0 PROPERTY DETAILS

2.1 Location and Access

The Property is situated approximately 175 km northwest of Sudbury, Ontario and approximately 120 km southwest of Timmins, Ontario (Figure 1). The Property located in Heenan and Benton Townships.

Access for this work was by pickup truck and atv’s along logging roads branching off of the Sultan Industrial Road.

2.2 Topography and Vegetation

The topography of the Property is characterized by rolling hills and flat areas separated by broad swamp areas, ponds, and lakes. Topographic relief is less than 25 metres in hilly areas where outcrop exposure is up to 5%. Forest cover is a combination of poplar, birch, jack pine, and cedar. Abundant water resources are present in the lakes, rivers, creeks, and beaver ponds on the Property. The mean elevation of the Property is approximately 395 m ASL.

2.3 Claims

The Property is bounded by UTM coordinates 395,115 E to 397,925 E, and 5,290,200 N to 5,292,145 N (NAD83, Z17N), and is covered by National Topographic System (NTS) map sheet 041O16 and 041O09. The Property consists of 26 unpatented mining claims, covering an area of approximately 390 ha (Table 1, Figure 2).

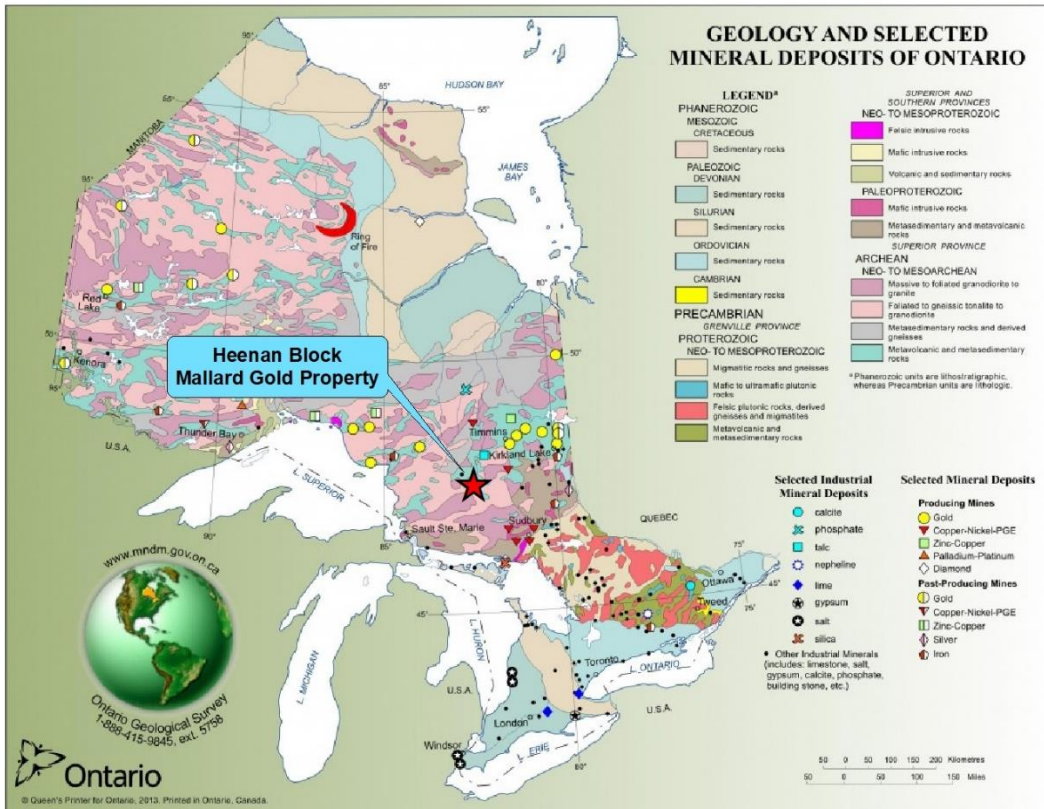

Figure 1: General Location of the Heenan Block, Mallard Gold Property, Ontario.

Table 1: Claim Details of the Heenan Block, Mallard Gold Property

Township / Area	Tenure ID	Anniversary Date	Work Required	Work Applied	Exploration Reserve
HEENAN	333290	2021-09-15	\$400	\$800	\$0
HEENAN	333289	2021-09-15	\$400	\$800	\$0
HEENAN	318644	2021-09-15	\$200	\$400	\$0
BENTON,HEENAN	301913	2021-09-15	\$200	\$400	\$0
HEENAN	284179	2021-09-15	\$200	\$499	\$0
BENTON,HEENAN	272068	2021-09-15	\$200	\$400	\$0
HEENAN	271480	2021-09-15	\$400	\$400	\$0
HEENAN	264023	2021-09-15	\$400	\$800	\$0
BENTON,HEENAN	218179	2021-09-15	\$200	\$400	\$0
HEENAN	217600	2021-09-15	\$200	\$400	\$208
HEENAN	206058	2021-09-15	\$200	\$400	\$0
HEENAN	152137	2021-09-15	\$400	\$800	\$2
HEENAN	134010	2021-09-15	\$200	\$400	\$0
HEENAN	115129	2021-09-15	\$400	\$800	\$0
HEENAN	333211	2021-09-15	\$200	\$400	\$698
HEENAN	284101	2021-09-15	\$200	\$400	\$185
HEENAN	271481	2021-09-15	\$200	\$400	\$805
HEENAN	271479	2021-09-15	\$400	\$400	\$0
HEENAN	234746	2021-09-15	\$200	\$400	\$820
HEENAN	234745	2021-09-15	\$400	\$400	\$0
HEENAN	168707	2021-09-15	\$200	\$400	\$0
HEENAN	168706	2021-09-15	\$400	\$400	\$0
HEENAN	152136	2021-09-15	\$400	\$800	\$91
HEENAN	152135	2021-09-15	\$200	\$400	\$0
HEENAN	133927	2021-09-15	\$400	\$800	\$0
HEENAN	272067	2022-09-15	\$400	\$1,200	\$407

3.0 PREVIOUS WORK

1906-1907: Algoma Steel Corp. acquired the Property to evaluate it for its iron potential. A total of 9344.2 linear feet of trenching was completed and sampled.

1946: Fummerton Mining and Development Compnay Ltd. acquired claims over the current claims and completed geological and geophysical surveys (magnetometer) over the property to outline the iron formation and possible favourable structures for gold mineralization. Two small syenite intrusives occurring on historical mining patent W.S.8 were reported to contain gold mineralization.

1959-1975: W.G. Wahl acquired patents W.S. 8 through to W.S. 12 and completed vertical field magnetic survey and trenching/pitting over the iron formation.

2006: Vencan Gold Corp. held claims throughout Benton, Genoa, Heenan, Mallard, & Marion Townships and completed a significant field program consisting of airborne electromagnetic and magnetic surveying, as well as minor prospecting over the current claims. Several anomalies were suggested for follow up ground-truthing. It appears that this was not completed as only one sample seems to have been reported on that is located in the northern part of claim 133927 that returned 446 ppb Au in an area shown to be at the mafic volcanic/iron formation contact.

2018-2019: Fancamp completed a geochemical program (B-horizon) and prospecting. Highlights from the programs returned geochemical values that ranged from <5ppb to 1,000 ppb Au, and grab samples that ranged from <5ppb to 418 ppb Au. There is no evidence of any historical diamond drilling in the assessment files over this target.

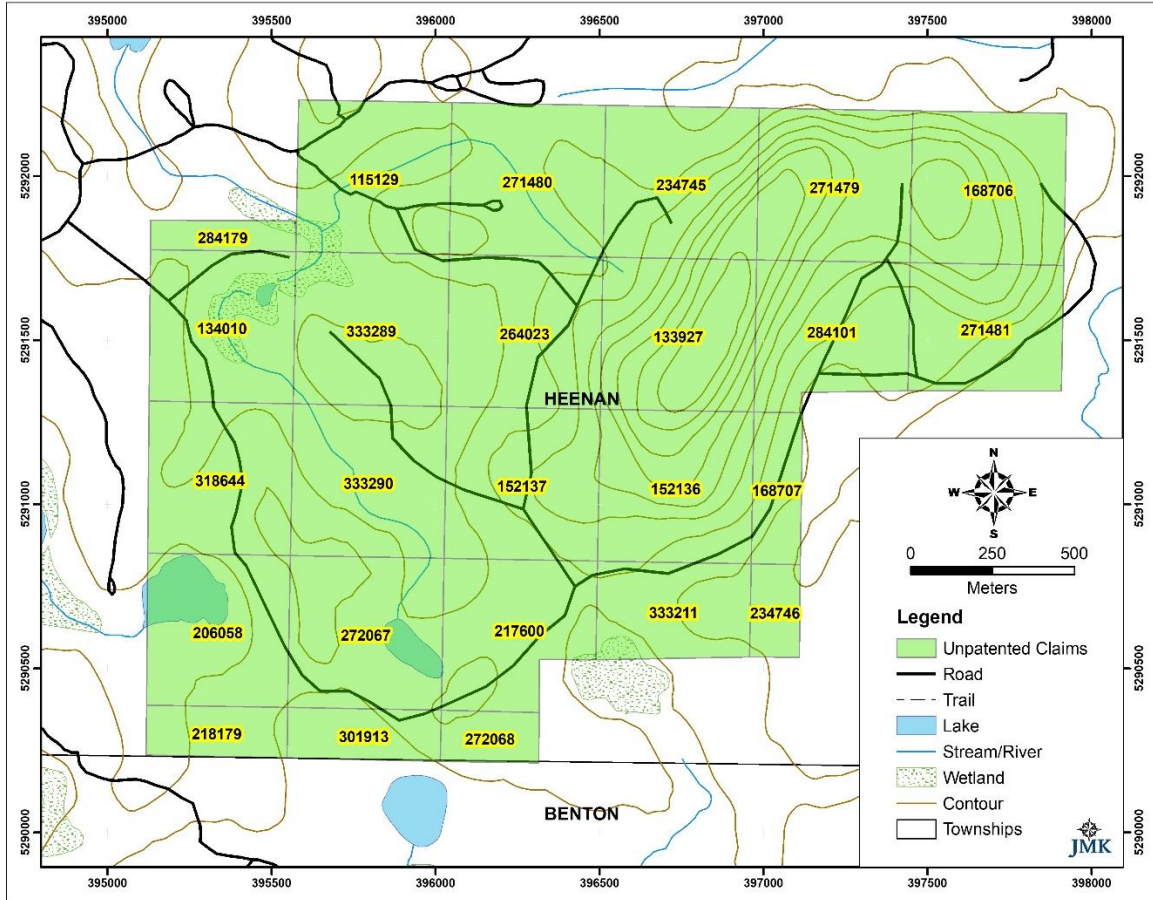

Figure 2: Tenure of the Heenan Block, Mallard Gold Property.

4.0 GEOLOGY

4.1 Property Geology

The Property is located within the Woman River anticline and is centered on the Woman River iron formation, which divides overlying mafic volcanic rocks of the October Lake formation to the northwest and west from underlying, calc-alkaline, felsic to intermediate volcanic rocks and sub-volcanic porphyries of the Strata Lake formation to the southeast (Figure 4). The Strata Lake formation occurs within the upper portions of the Marion Group which is thought to correlate with the Deloro assemblage of the southern Abitibi belt, based on U-Pb geochronology, (van Breemen, et.al, 2006). Van Breemen, et.al., describe the upper portions of the Strata Lake formation as “dominated by variably

chloritized and sulphidized volcanic rocks related to crackle breccia zones that are interpreted to represent paleo-hydrothermal conduits for iron-rich fluids that precipitated out of the overlying ironstones”.

Upon review of airborne geophysical data available through MENDM’s digital database of geoscience assessment work, the iron formation located at the west end of the Property appears to have been displaced at a possible fold nose for a distance of approximately 1.1 km by a dextral strike-slip fault, informally termed the Mallard Shear zone, a regional structure which is part of several northwest – southeast directed fault structures that may have provided conduits for hydrothermal fluids to deposit mineralization at favorable horizons within the stratigraphy, particularly at the contact of the felsic volcanic rocks with the iron formations. The area of the fold nose, transected by the shear represents an excellent target for further exploration (Flanagan, 2018).

To the northeast of the Property, local areas within the iron formations, particularly adjacent to the underlying felsic volcanic rocks contain prospective zones of quartz-carbonate veining which appear to host gold, often directly adjacent to feldspar-quartz porphyries.

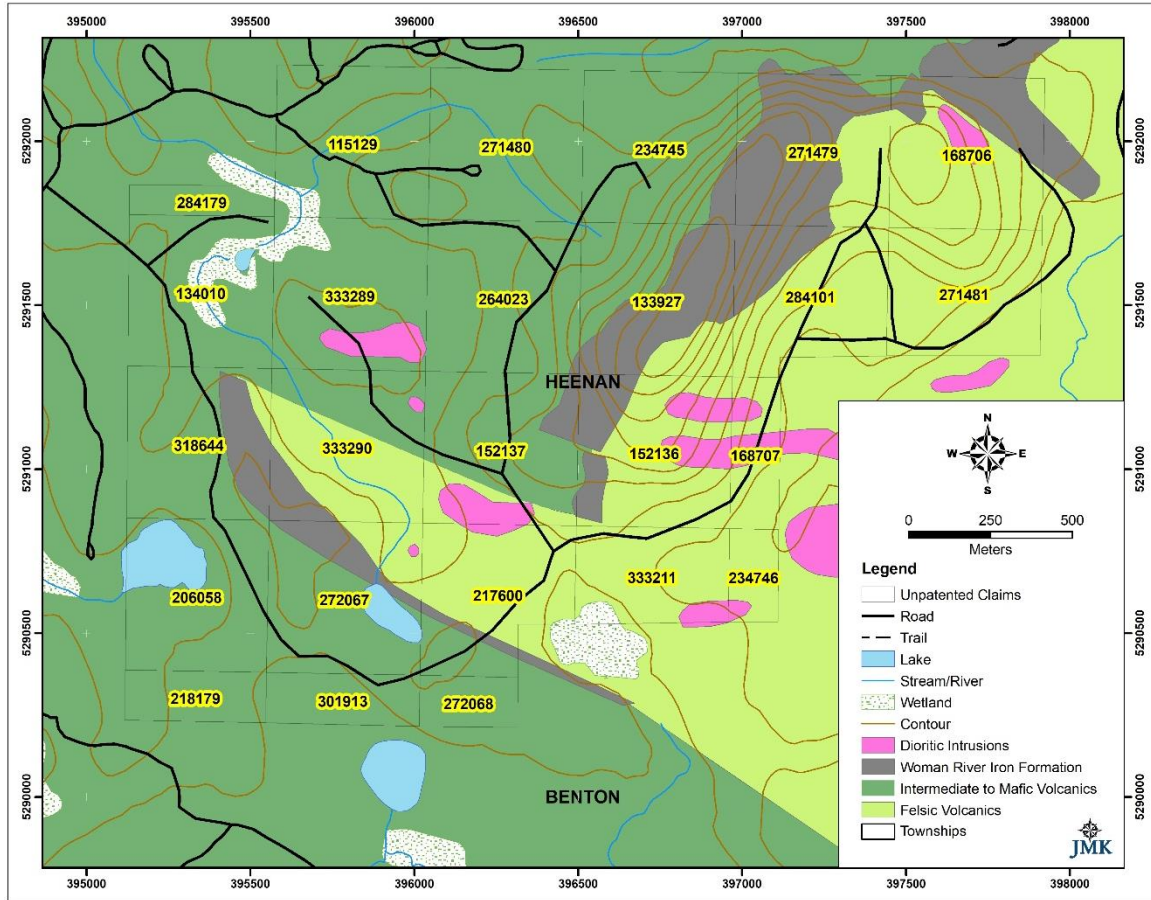

Figure 3: Property Geology (after OGS P2067).

5.0 2019 GEOPHYSICAL PROGRAM

5.1 Methods – Induced Polarization

The Induced Polarization (“IP”) method involves applying voltage across two electrodes in a pulsed manner, for example, 2 seconds on, and 2 seconds off. A second “dipole” or electrode pair measures the residual potential or voltage between them after the voltage is shut off during the 2 second off cycle. The potential is recorded at different times after the shut off. If, for example, there is sulphide mineralization within the measuring dipoles, they will be polarized or charges set up on the individual sulphide particles. This polarization gives the zone a capacitor effect, thereby delaying the current dissipation resulting in a higher chargeability reading (residual voltage), across the measuring

dipoles at pre-set time windows, during the 2 second transmitter shut off period (Meikle, 2019).

A typical IP response for gold target would include a moderate to high chargeability, high resistivity, and a magnetic low. This would be characteristic of disseminated sulphide mineralization, along with alteration of the host rocks (carbonatization and/or silicification). However, this is by no means the only geological setting for gold, therefore every IP profile should be looked at individually and correlated with all other geophysical and geological data (Meikle, 2019).

A typical IP response for base metal mineralization such as copper, and or nickel would be a higher chargeability anomaly associated with a higher concentration of sulphides and a low resistivity due to the conductivity of the style of sulphide mineralization associated with this mineralization type (Meikle, 2019).

The survey was completed using a Pole-Dipole array. In this array, one current electrode (“C1”), is placed at “infinity” usually greater than 1 km from the survey area, normal to assumed strike direction. The other current electrode (“C2”) is moved down a picket line in 25m intervals, preceded by 7 potential electrodes or dipole pairs spaced 25 m apart (“A” spacing). For a N=1 reading, the first pair of potential electrodes are placed 25m meters from the C2 current electrode. Successive dipole electrode pairs are read from the same C2 position to obtain the remaining N=2-6, with the farthest electrode pair from the current electrode having a greater depth of penetration (Meikle, 2019).

The following survey parameters were used for the survey:

Method: Time Domain

Electrode Array: Pole-Dipole

“A” spacing: 25 m

Number of dipoles read: N=1-6

Pulse Duration: 2 sec on/off

Delay Time after current shut off to first time window: 310 ms

Integration Time (width of windows): 140 ms

Receiver: IRIS Elrec-Pro

Transmitter: GDD 5KVA, square wave, Time Domain with 5KW Honda Mg

5.2 Methods – Magnetometer

A total of 6.7 km of ground magnetometer surveying was completed. Gem Systems GSM-19 overhauser magnetometers were used both field and base station units. These units have an accuracy of +/- 1/100th of a gamma. The base station cycled at 15 second intervals. Readings were taken at 12.5 m spaced intervals along the cut grid lines.

5.3 Results

Plan maps of the IP (chargeability, resistivity), IP pseudosections, and magnetometer results are provided at a scale of 1:2500 in Appendix II.

Two strong magnetic features were identified in survey and are associated with the known surface expression of the Woman River Iron Formation. The main feature is approximately 600 m in length, and ranges from L8+00E through to L3+00E, basically located just grid south of the baseline and orientated northwest-southeast. Between L2+00E and L3+00E, the iron formation is faulted, and becomes northeast trending between L1+00E and L2+00E for a surveyed length of 150-200m. This area may have also been previously folded prior to the northeast orientated inferred fault.

Results from the IP survey indicate several moderate to strong chargeability anomalies associated with magnetic highs and highly anomalous geochemical and prospecting samples. Coinciding resistivity measurements are locally slightly elevated and may represent some degree of silicification within the iron formation.

6.0 CONCLUSIONS AND RECOMMENDATIONS

The IP and magnetometer geophysical surveys mapped the geophysical properties over an anomalous area identified by recently completed geochemical and prospecting programs. Highlights from the programs returned geochemical values (B-horizon) that ranged from <5ppb to 1,000 ppb Au, and grab samples that ranged from <5ppb to 418 ppb Au. There is no evidence of any historical diamond drilling in the assessment files over this target.

It is recommended that some of these IP anomalies, specifically the ones located at L7+00E/0+50S, L6+00E/0+50S, L5+00E/0+50S and L4+00E/0+50S be tested by diamond drilling. The targets on L7+00E, L6+00E, and L5+00E correspond with the location of anomalous geochemical or prospecting results. The magnetometer data suggests a steep dip grid south for the iron formation, and the azimuths for the proposed drill holes should be oriented grid north. An aggregate of 600 m of diamond drilling would be sufficient for a first phase of drilling.

7.0 REFERENCES

Ayer, J.A. and Chartrand, J.E. 2011. Geological compilation of the Abitibi greenstone belt; Ontario Geological Survey, Miscellaneous Release—Data 282.

Flanagan, M., 2018. Internal report, Fancamp Exploration Ltd. Heenan Township, Ontario, Webster-Watson Claims.

Goodwin, A.M., 1965. Geology of Heenan, Marion, and Northern Genoa Townships, Ontario Department of Mines., Geological Report No. 38.

Meikle, R.J., 2019. Report on an Induced Polarization/Magnetometer Geophysical Survey on the Dorothy Lake Property, Meggisi Lake Area, Kenora Mining Division, Ontario.

Ministry of Northern Development and Mines; Geology of Ontario, Assessment File Research Information (AFRI) found at www.geologyontario.mndm.gov.on.ca

Tykajlo, R., 2006. Report on the Vencan Gold Corp. Cayenne-Chili Gold Property, 2005 Geophysical Exploration Program, Heenan, Marion, Mallard, and Genoa Townships, Swayze Area, Ontario.

Van Breeman, O., Heather, K.B., Ayer, J.A., 2006. U-Pb geochronology of the Neoproterozoic Swayze sector of the southern Abitibi greenstone belt, in Geological Survey of Canada, Current Research 2006. P. 1-32.

Appendix I

Statement of Qualifications

Statement of Qualifications

I, Joerg Martin Kleinboeck of 147 Lakeside Drive, North Bay, Ontario, do hereby certify that:

I am a graduate of Laurentian University, Sudbury, Ontario with a B.Sc. Geology, 2000, and have been practising my profession as a geologist since.

I am a member with the Association of Professional Geoscientists of Ontario (#1411).

I am a member of the Ontario Prospectors Association.

I hold no interests in the securities of Fancamp Exploration Ltd., and I am independent of the subject Property.



The image shows a handwritten signature in cursive script, followed by a circular professional seal. The seal contains the text: "PROFESSIONAL GEOSCIENTISTS", "JOERG M. KLEINBOECK", "PRACTISING MEMBER", "1411", and "ONTARIO".

Joerg Martin Kleinboeck
JMK Exploration Consulting
March 24th, 2020
North Bay, Ontario

Appendix II

Maps

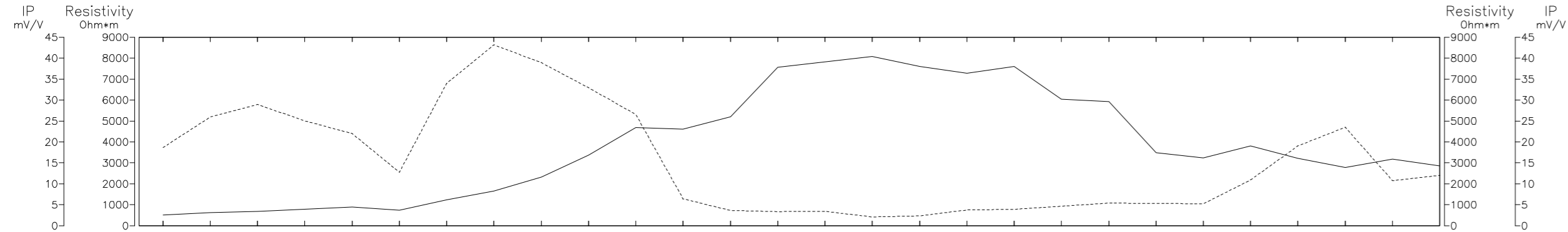

Pseudo Section Plot 1+00 E

Pole-Dipole Array

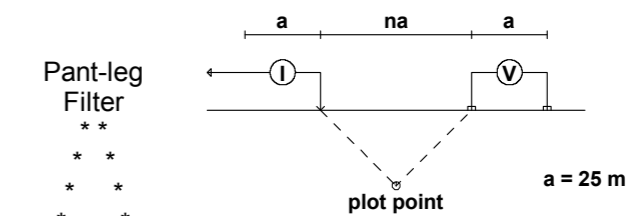

Logarithmic Contours: 1.5, 2, 3, 5, 7.5, 10, ...

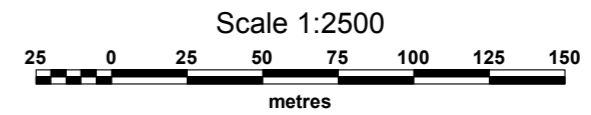
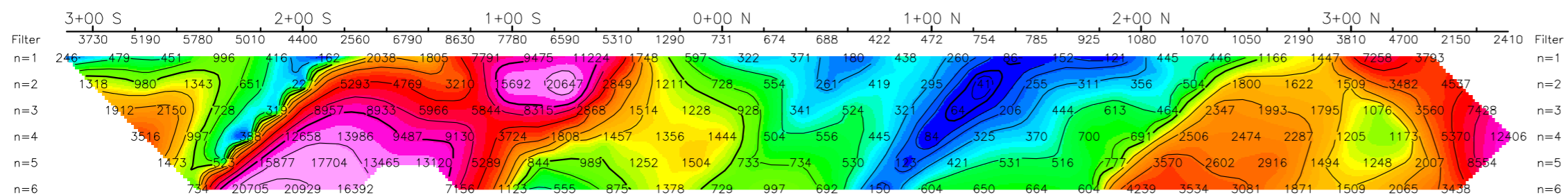
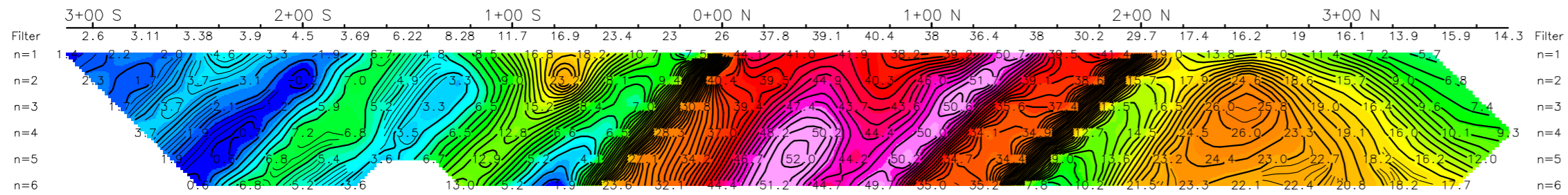

FANCAMP EXPLORATION LTD.
INDUCED POLARIZATION SURVEY
MALLARD GOLD PROJECT
HEENAN BLOCK
 Heenan Township
 Porcupine Mining Division
RAY MEIKLE AND ASSOCIATES

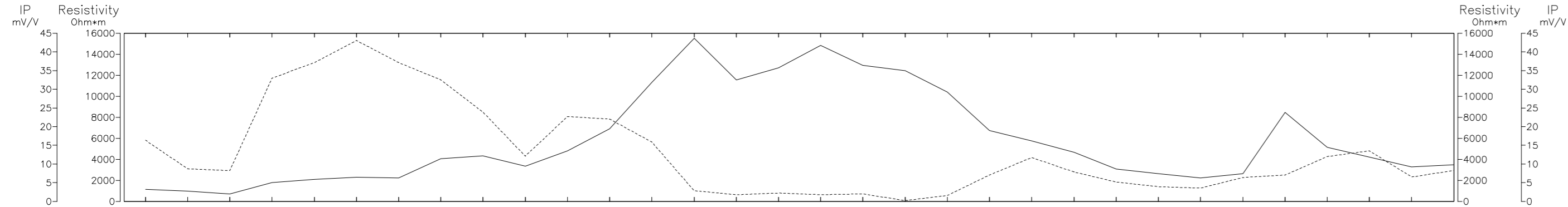

Pseudo Section Plot 2+00 E

Pole-Dipole Array

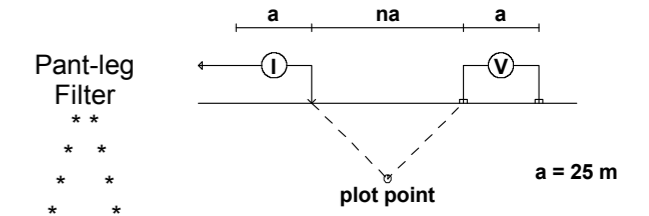

Pant-leg
Filter
* *
* *
* *

Logarithmic
Contours
1.5, 2, 3, 5, 7.5, 10,...

Scale 1:2500

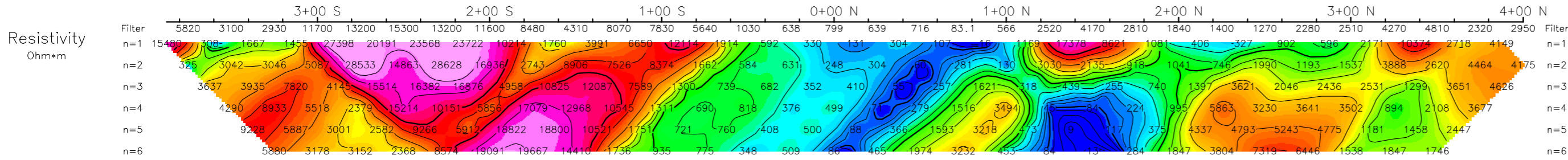
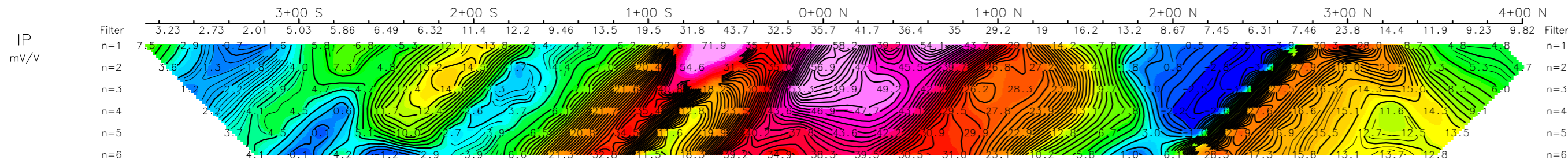
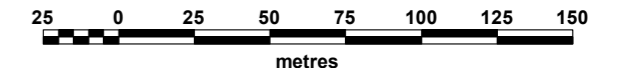

FANCAMP EXPLORATION LTD.
INDUCED POLARIZATION SURVEY
MALLARD GOLD PROJECT
HEENAN BLOCK
 Heenan Township
 Porcupine Mining Division
RAY MEIKLE AND ASSOCIATES

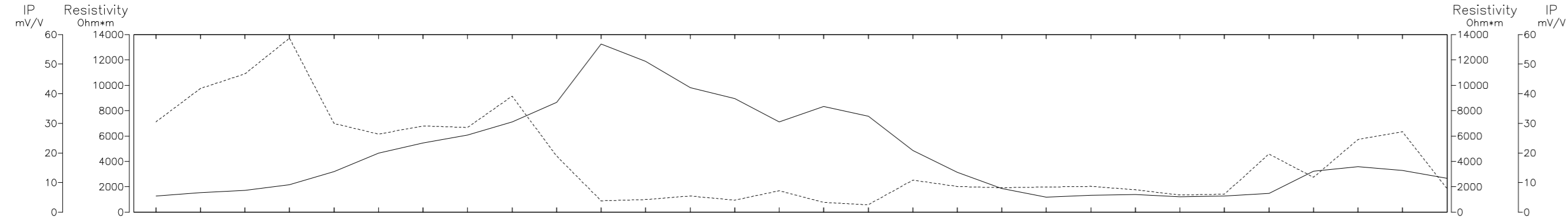

Pseudo Section Plot 3+00 E

Pole-Dipole Array

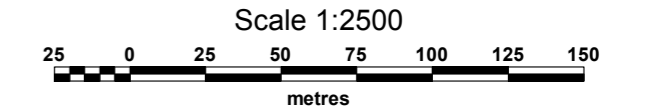
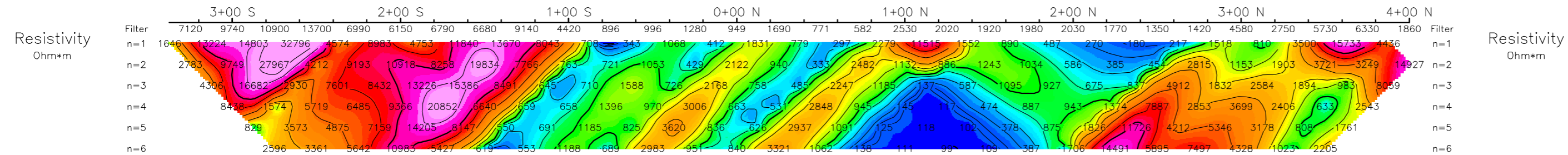
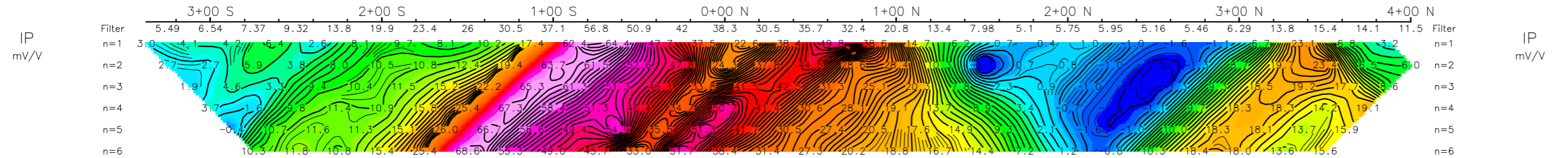
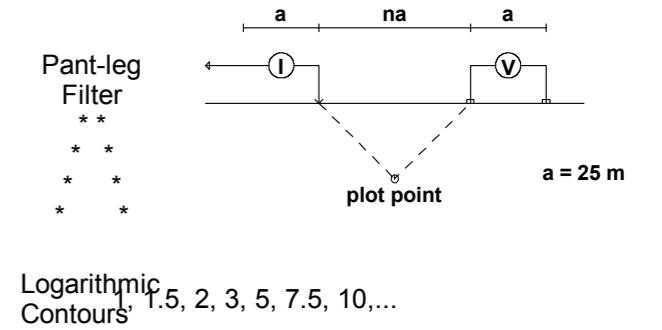

FANCAMP EXPLORATION LTD.
INDUCED POLARIZATION SURVEY
MALLARD GOLD PROJECT
HEENAN BLOCK
 Heenan Township
 Porcupine Mining Division
RAY MEIKLE AND ASSOCIATES

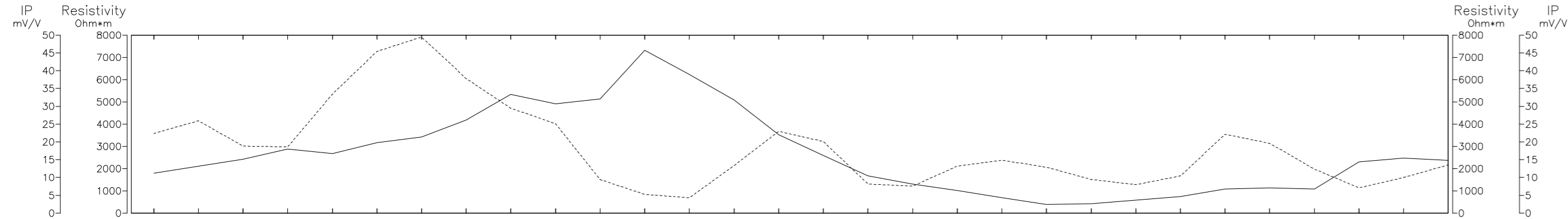

Pseudo Section Plot

4+00 E

Pole-Dipole Array

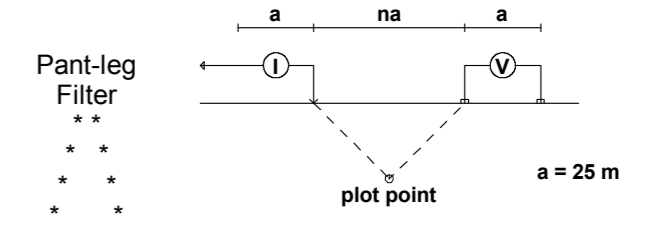

Logarithmic Contours
1, 1.5, 2, 3, 5, 7.5, 10, ...

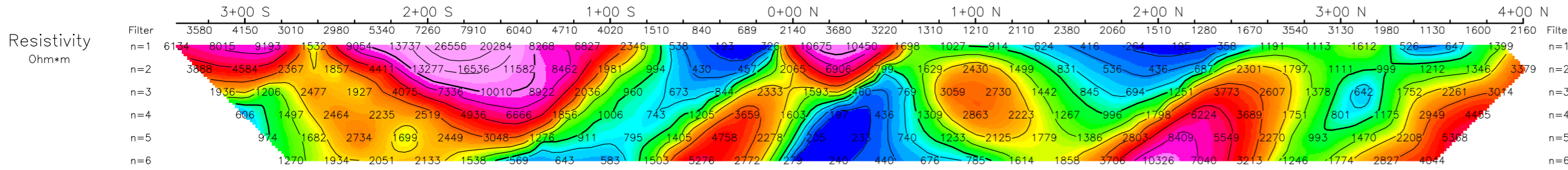
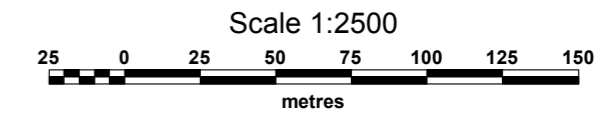
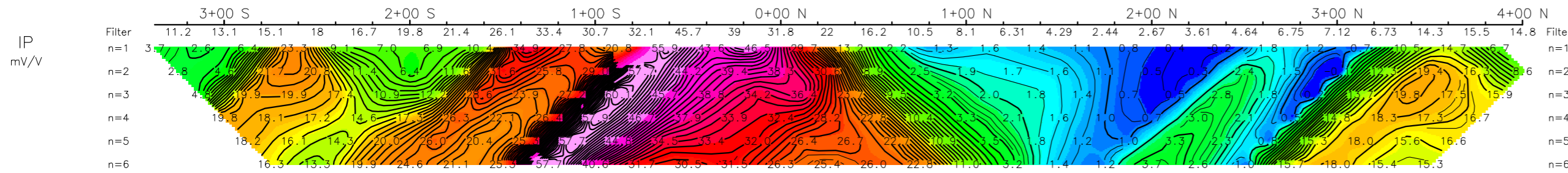

FANCAMP EXPLORATION LTD.
INDUCED POLARIZATION SURVEY
MALLARD GOLD PROJECT
HEENAN BLOCK
 Heenan Township
 Porcupine Mining Division
RAY MEIKLE AND ASSOCIATES

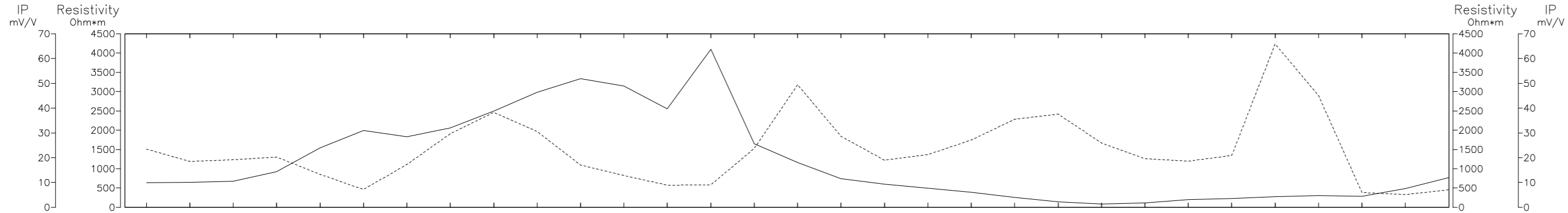

Pseudo Section Plot 5+00 E

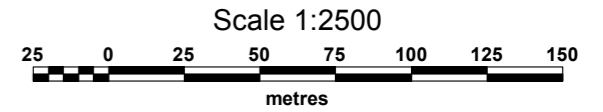
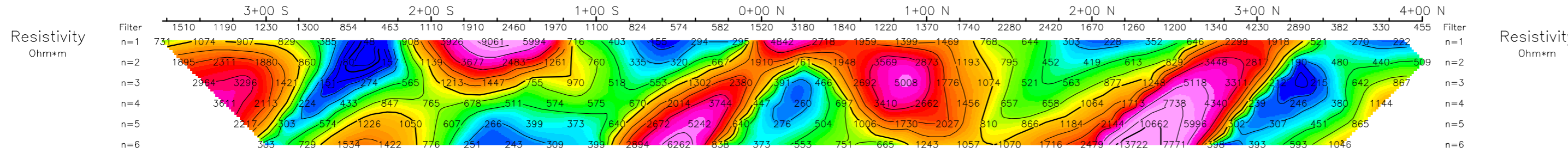
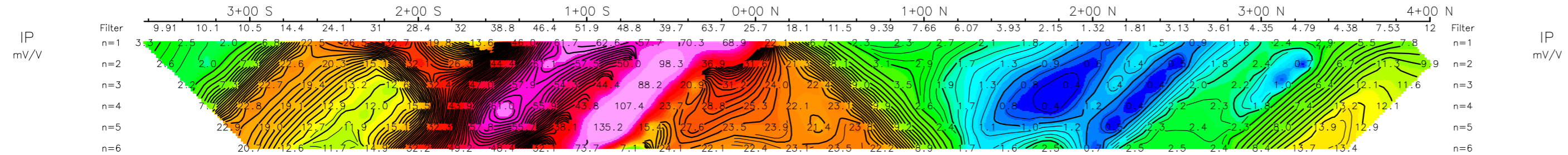
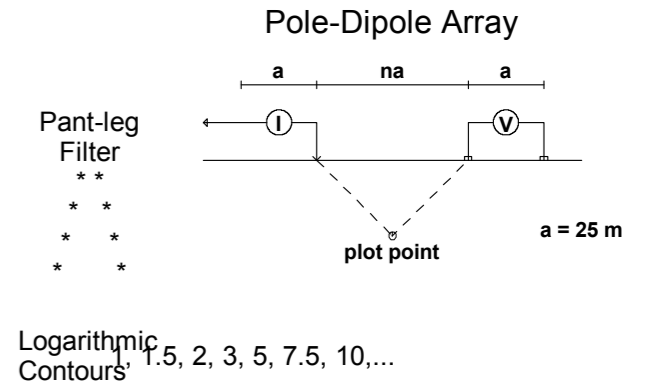

FANCAMP EXPLORATION LTD.
INDUCED POLARIZATION SURVEY
MALLARD GOLD PROJECT
HEENAN BLOCK
 Heenan Township
 Porcupine Mining Division
RAY MEIKLE AND ASSOCIATES

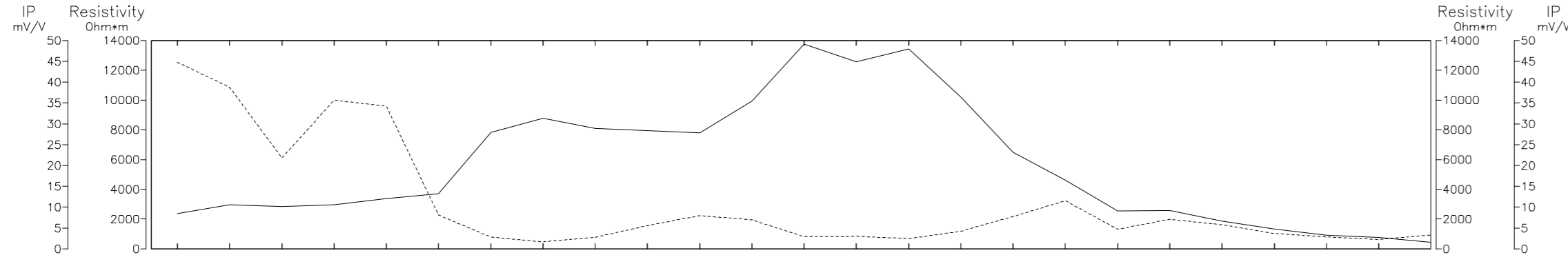

Pseudo Section Plot

6+00 E

Pole-Dipole Array

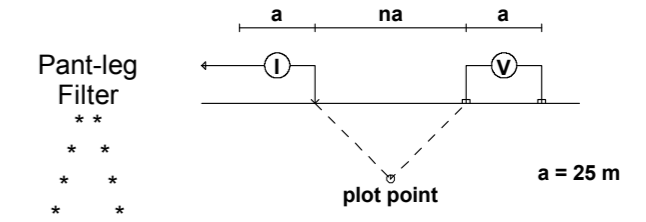

Logarithmic Contours
1.5, 2, 3, 5, 7.5, 10,...

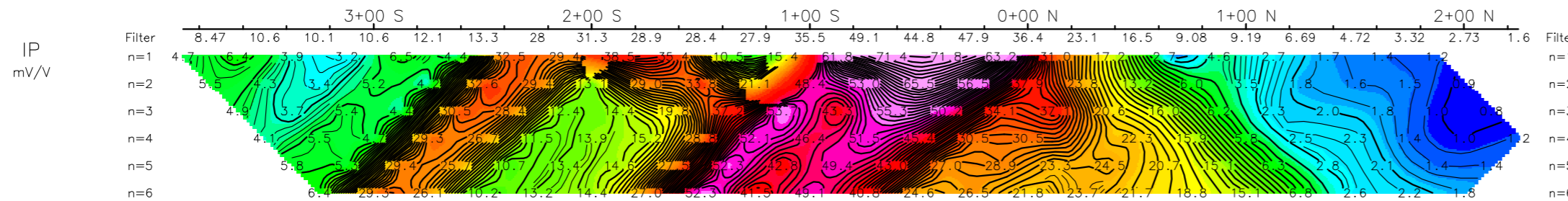

IP
mV/V

Resistivity
Ohm*m

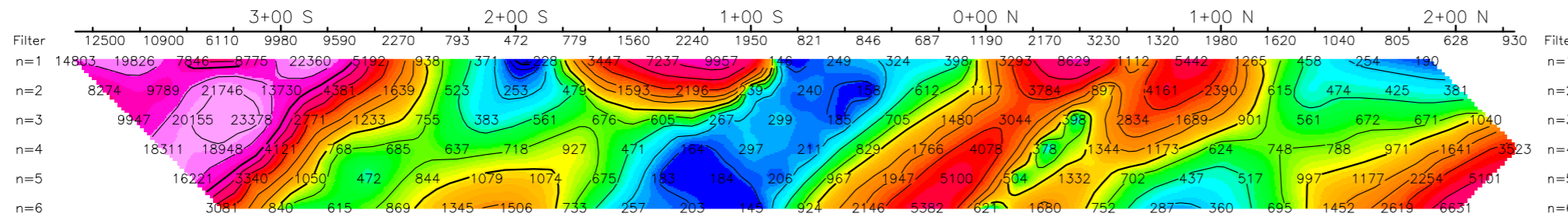

Resistivity
Ohm*m

Resistivity
Ohm*m

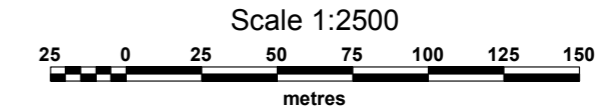

FANCAMP EXPLORATION LTD.
INDUCED POLARIZATION SURVEY
MALLARD GOLD PROJECT
HEENAN BLOCK

Heenan Township
Porcupine Mining Division

RAY MEIKLE AND ASSOCIATES

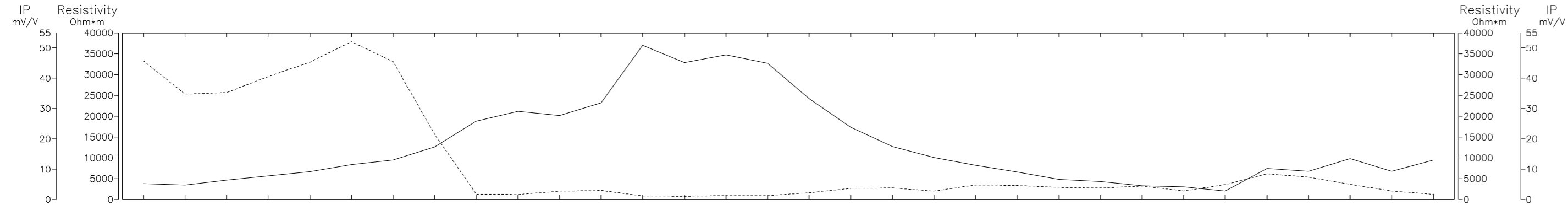

Pseudo Section Plot 7+00 E

Pole-Dipole Array

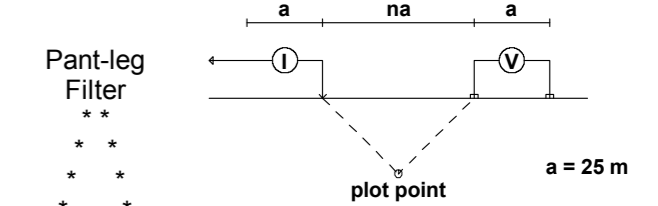

Logarithmic Contours: 1.5, 2, 3, 5, 7.5, 10, ...

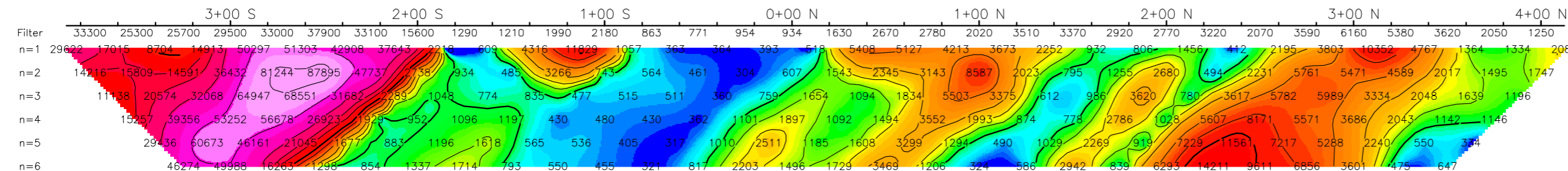
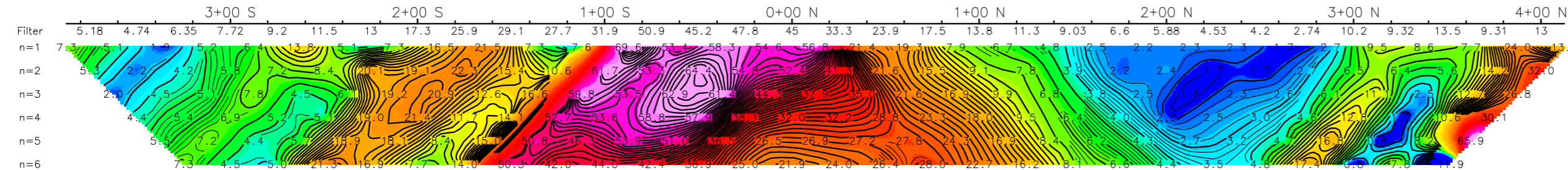
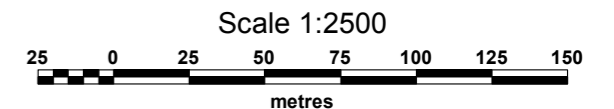

IP
mV/V

Resistivity
Ohm*m

FANCAMP EXPLORATION LTD.
INDUCED POLARIZATION SURVEY
MALLARD GOLD PROJECT
HEENAN BLOCK

Heenan Township
Porcupine Mining Division

RAY MEIKLE AND ASSOCIATES

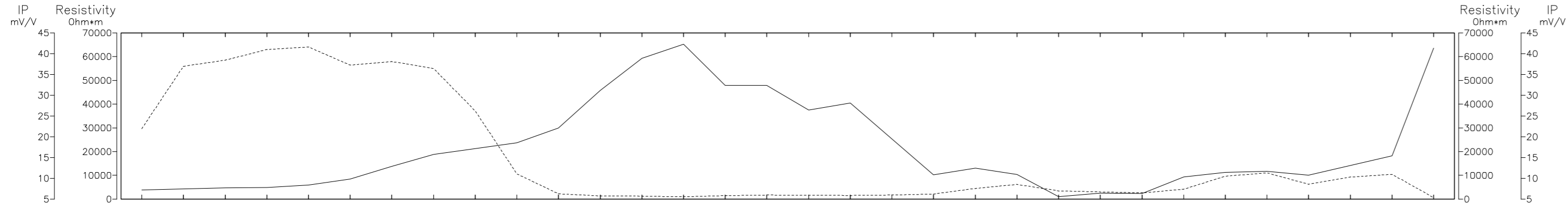

Pseudo Section Plot

8+00 E

Pole-Dipole Array

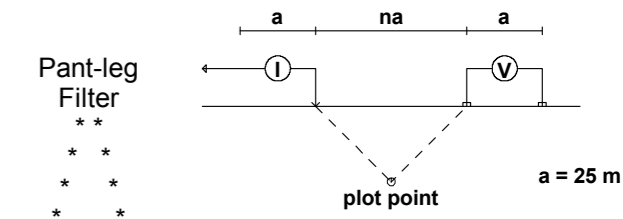

Logarithmic Contours: 1.5, 2, 3, 5, 7.5, 10, ...

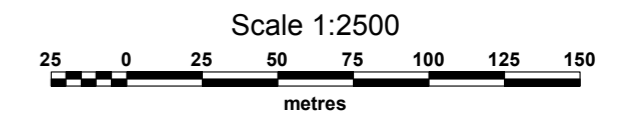
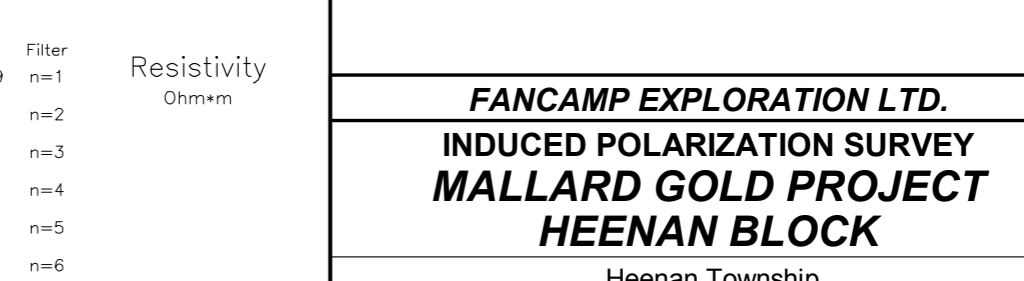
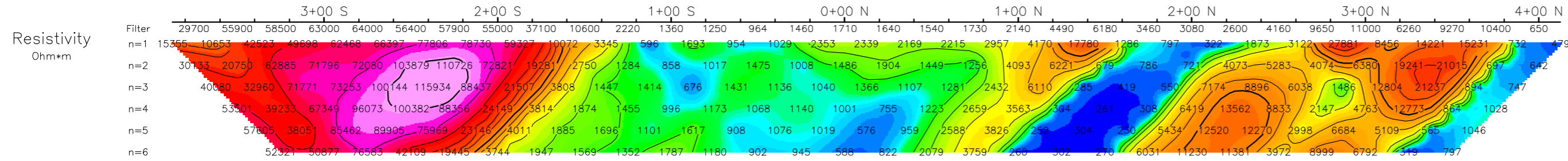
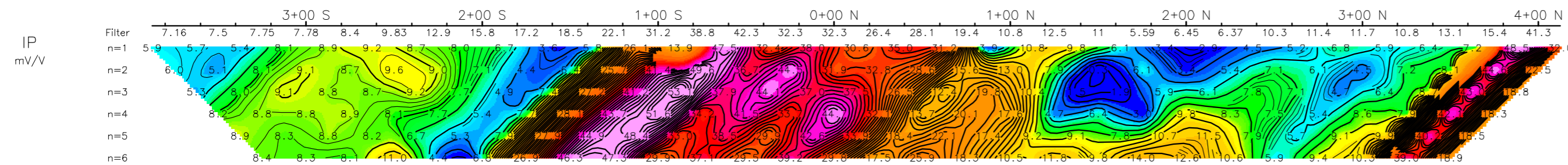

FANCAMP EXPLORATION LTD.
INDUCED POLARIZATION SURVEY
MALLARD GOLD PROJECT
HEENAN BLOCK
 Heenan Township
 Porcupine Mining Division
RAY MEIKLE AND ASSOCIATES

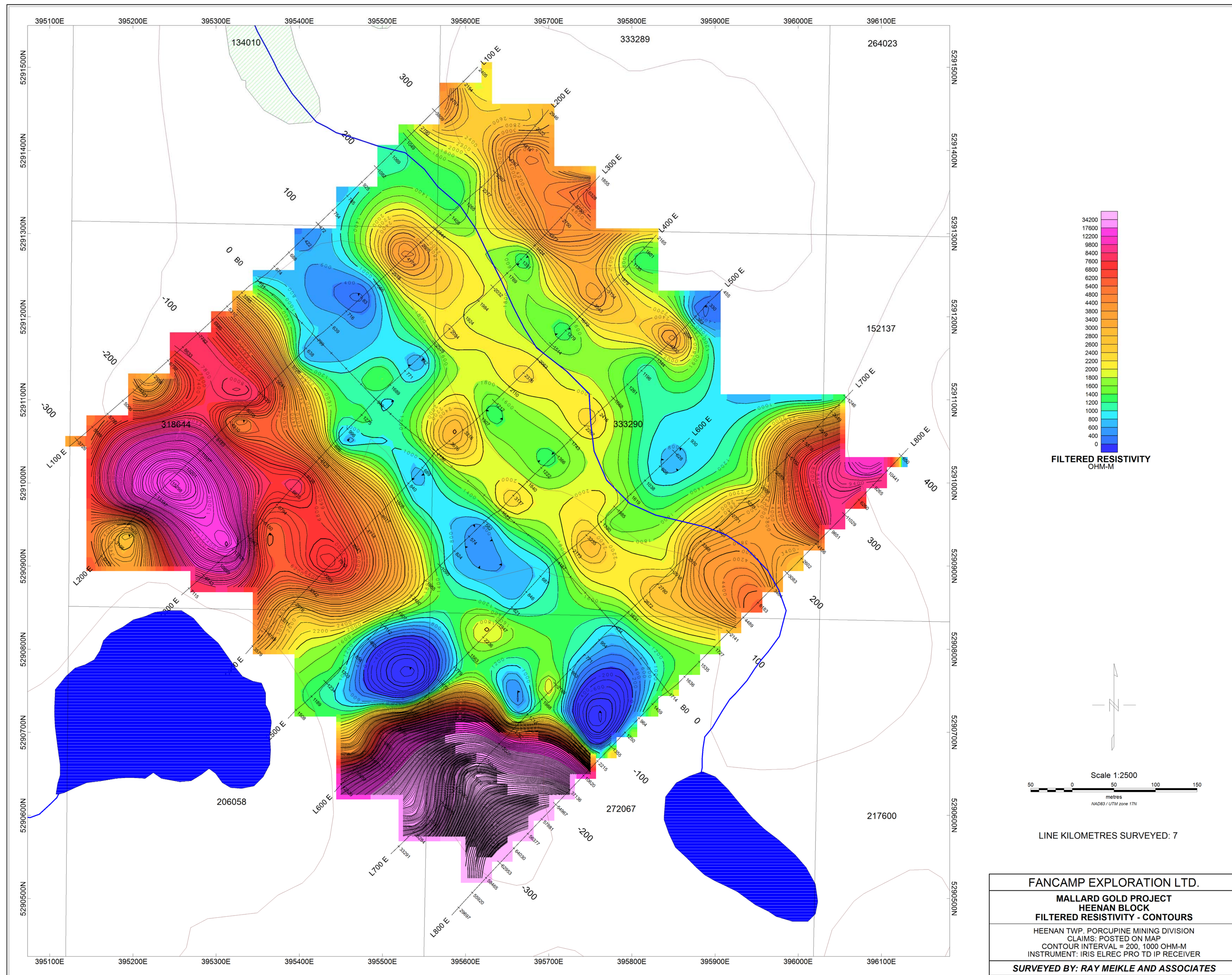

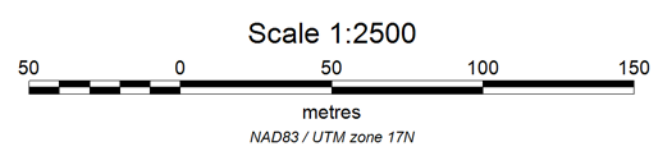
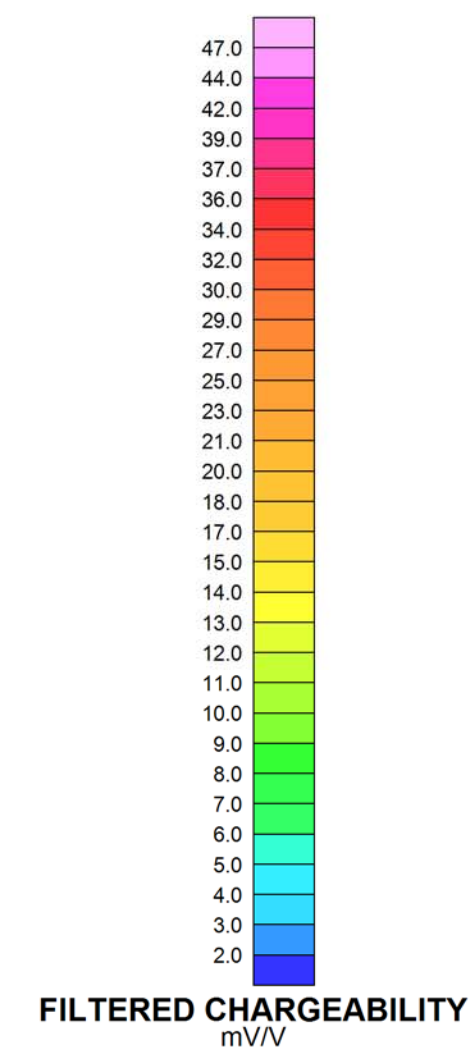
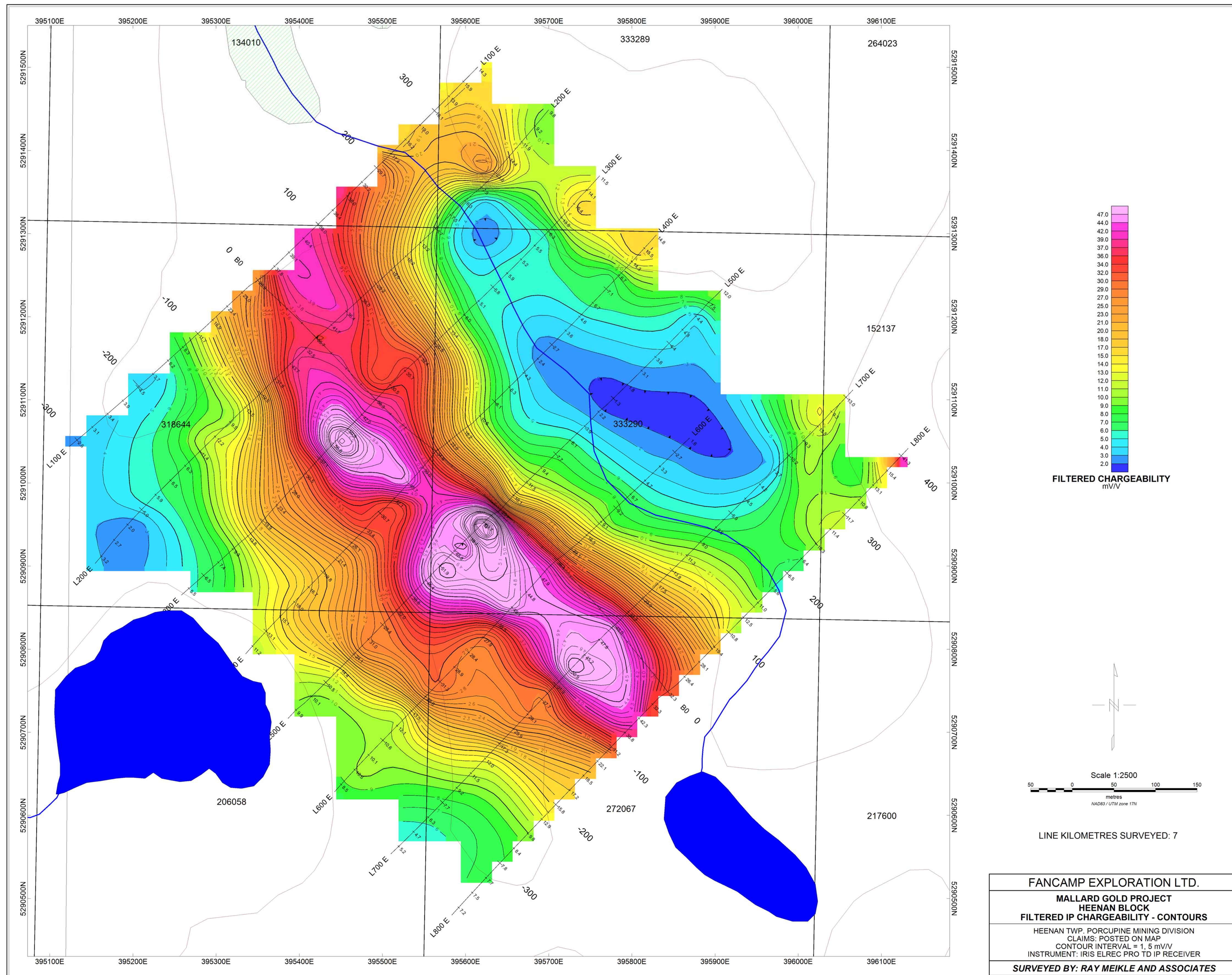

LINE KILOMETRES SURVEYED: 7

FANCAMP EXPLORATION LTD.
MALLARD GOLD PROJECT HEENAN BLOCK
FILTERED IP CHARGEABILITY - CONTOURS
HEENAN TWP. PORCUPINE MINING DIVISION CLAIMS: POSTED ON MAP CONTOUR INTERVAL = 1.5 mV/V INSTRUMENT: IRIS ELREC PRO TD IP RECEIVER
SURVEYED BY: RAY MEIKLE AND ASSOCIATES

