



32E055E0012 2.9789 HURTUBISE

010

INTERPRETATION REPORT  
INPUT MK VI ELECTROMAGNETIC/MAGNETIC SURVEY  
GLEN AUDEN RESOURCES LIMITED  
CONSCOTT RESOURCES LTD. JOINT VENTURE  
Hurtubise/St. Laurent Township Area  
Project No. 28036A      December, 1986  
by  
Marcel Konning, P.Eng.  
Nadia Caira, B.Sc.

RECEIVED

FEB 10 1987

MINING DIVISION



	PAGE
SUMMARY AND RECOMMENDATIONS.....	i
INTRODUCTION.....	1
PROJECT LOCATION.....	2
PROPERTY.....	2
SURVEY OPERATIONS	
Survey Personnel.....	3
Instruments.....	4
Production.....	5
Products.....	5
Survey Procedure.....	6
Magnetic Diurnal.....	7
DATA COMPILATION	
Data Recovery.....	8
Computer Processing.....	10
INPUT DATA PRESENTATION.....	10
INTERPRETATION - GENERAL	
Geological Perspective.....	12
Conductivity Analysis.....	12
INPUT INTERPRETATION.....	15

APPENDICES

- APPENDIX A Barringer/Questor Mark VI INPUT (R) System
- APPENDIX B The Survey Aircraft
- APPENDIX C INPUT System Characteristics
- APPENDIX D INPUT Processing
- APPENDIX E INPUT Interpretation Procedures
- APPENDIX F INPUT Response Models
- APPENDIX G Quantitative Interpretation
- APPENDIX H Bibliography

LIST OF FIGURES

- |           |  |             |
|-----------|--|-------------|
| Figure 1  | Property Location Map                                | 1:250,000   |
| Figure 2  | Claim Map  | 1"=1/2 mile |
| Figure 3  | Airborne Input EM (Sheet 1)                          | 1:20,000    |
| Figure 4  | Total Magnetic Intensity<br>(Sheet 1)                | 1:20,000    |
| Figure 5  | Calculated Vertical Magnetic<br>Derivative (Sheet 1) | 1:20,000    |
| Figure 3a | Airborne Input EM (Sheet 2)                          | 1:20,000    |
| Figure 4a | Total Magnetic Intensity (Sheet 2)                   | 1:20,000    |
| Figure 5a | Calculated Vertical Magnetic Derivative (Sheet 2)    |             |

SUMMARY AND RECOMMENDATIONS

A total of 800 line-km of survey was flown with the Questor/Barringer MK VI, 2ms, INPUT system in November-December, 1986, on behalf of several exploration companies, over an area near Cochrane, Ontario. Conscott Resources Ltd. and Glen Auden Resources Limited holds a 92 claim property in Southeastern Hurlbise Township, Ontario all of which was covered by the Questor Survey.

The survey outlined several discrete bedrock conductors. Most of these anomalies appear to warrant further investigation using appropriate surface exploration techniques. Areas of interest may be assigned priorities for follow-up work on the basis of supporting geological and/or geochemical information.

The area of interest contains several anomalous features, many of which are considered to be of moderate to high priority as exploration targets.

## INTRODUCTION

A Questor airborne INPUT electromagnetic and magnetic survey totalling 214.28 line-km (133.93 line-miles) was flown with a 100m line-spacing for Glen Auden Resources Limited and Conscott Resources Ltd. 92 claim property in December, 1986, in the Cochrane Area of Ontario (Figure 1).

The property is located in southeastern Hurtubise Township, Larder Lake Mining Division, Ontario. The property covers an extension of the metavolcanics and iron formations that have been the subject of considerable exploration activity in the Casa Berardi area in Quebec. Potential for stratabound sulfide gold deposits exist on the property as well as possibilities for disseminated pyrite hosted gold deposits within porphyritic and/or felsic volcanic tuffs and gold associated with quartz veins in carbonate-sericite alteration zones within structurally deformed portions of the belt.

The survey was commissioned by Mr. R.S. Middleton of Glen Auden Resources Limited. Marcel H. Konings, P.Eng., Geophysicist for Questor, supervised the data compilation and interpretation through to the completion of the project in December, 1986.

The survey objective is the detection and location of base metal sulphide conductors as well as any structures and conductivity patterns which could have a positive influence on gold and base metal exploration.

PROJECT LOCATION

The property is located in southcentral Hurtubise Township, some 60 air miles northeast of Cochrane, Ontario (see Figure 1). Access to the property is by helicopter from Cochrane, however, a winter road could be extended east from the north-south Abitibi Paper Co. all weather road that crosses some 9 or 10 miles to the west of the property.

PROPERTY

The property consists of 92 claims in Hurtubise Township, Larder Lake Mining Division, Ontario.

Hurtubise Township

<u>Claim Number</u>	<u>No.</u>	<u>Recording Date</u>
877632-877650	19	December 27, 1985
877686-877699	14	December 27, 1985
877731-877768	38	December 27, 1985
878006-878023	18	December 27, 1985
878083-878085	3	December 27, 1985
	<u>92</u>	

The claims are transferred into Glen Auden Resources Limited name.

**LEGEND**

- 5 Felsic Intrusive Rocks
- 4 Mafic Intrusive Rocks
- 3 Metasedimentary Rocks
- 2 Felsic to Intermediate Metavolcanic Rocks
- 1 Mafic Metavolcanic Rocks
- IF Iron Formation
- ★ Gold Showing

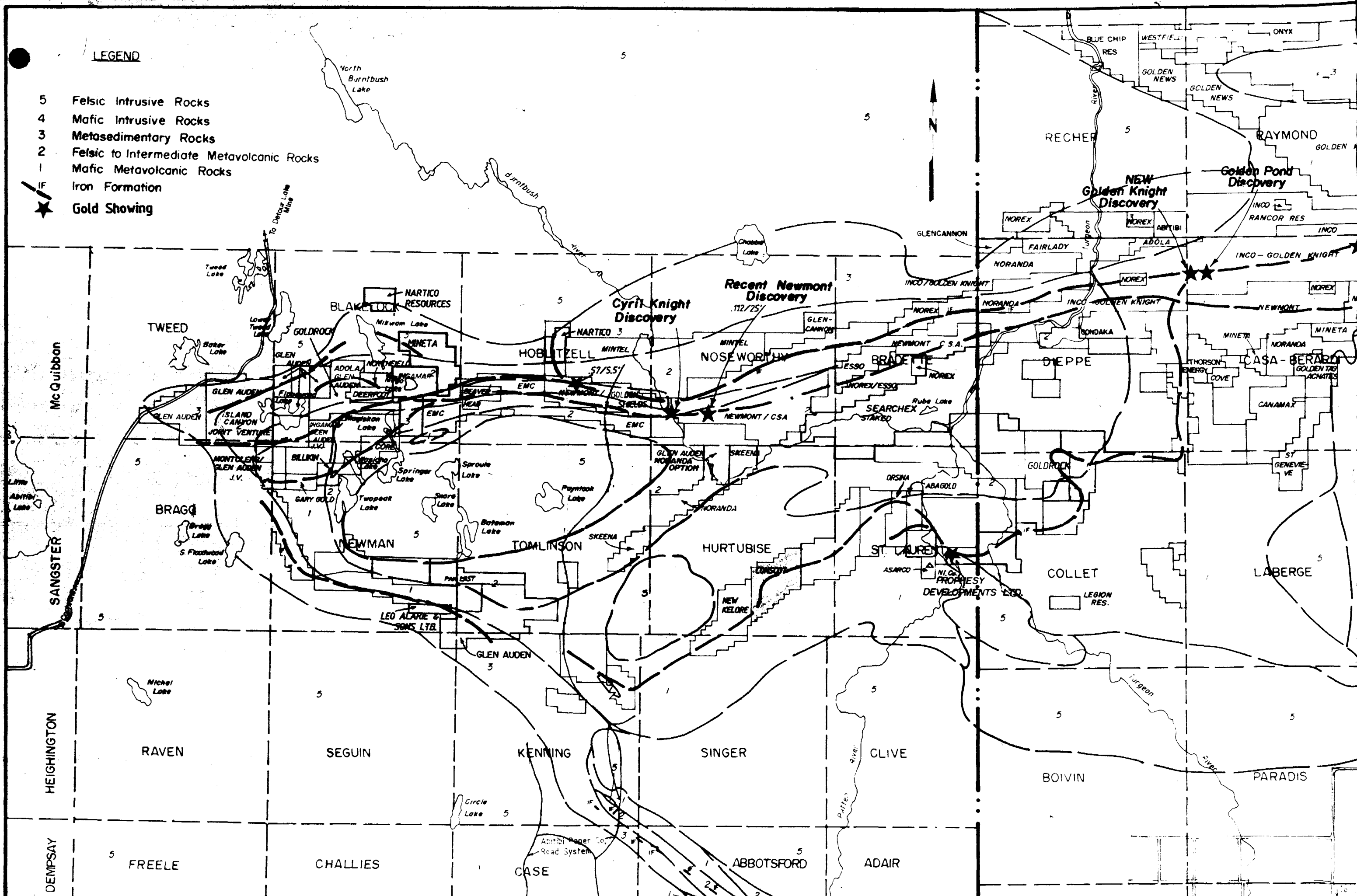

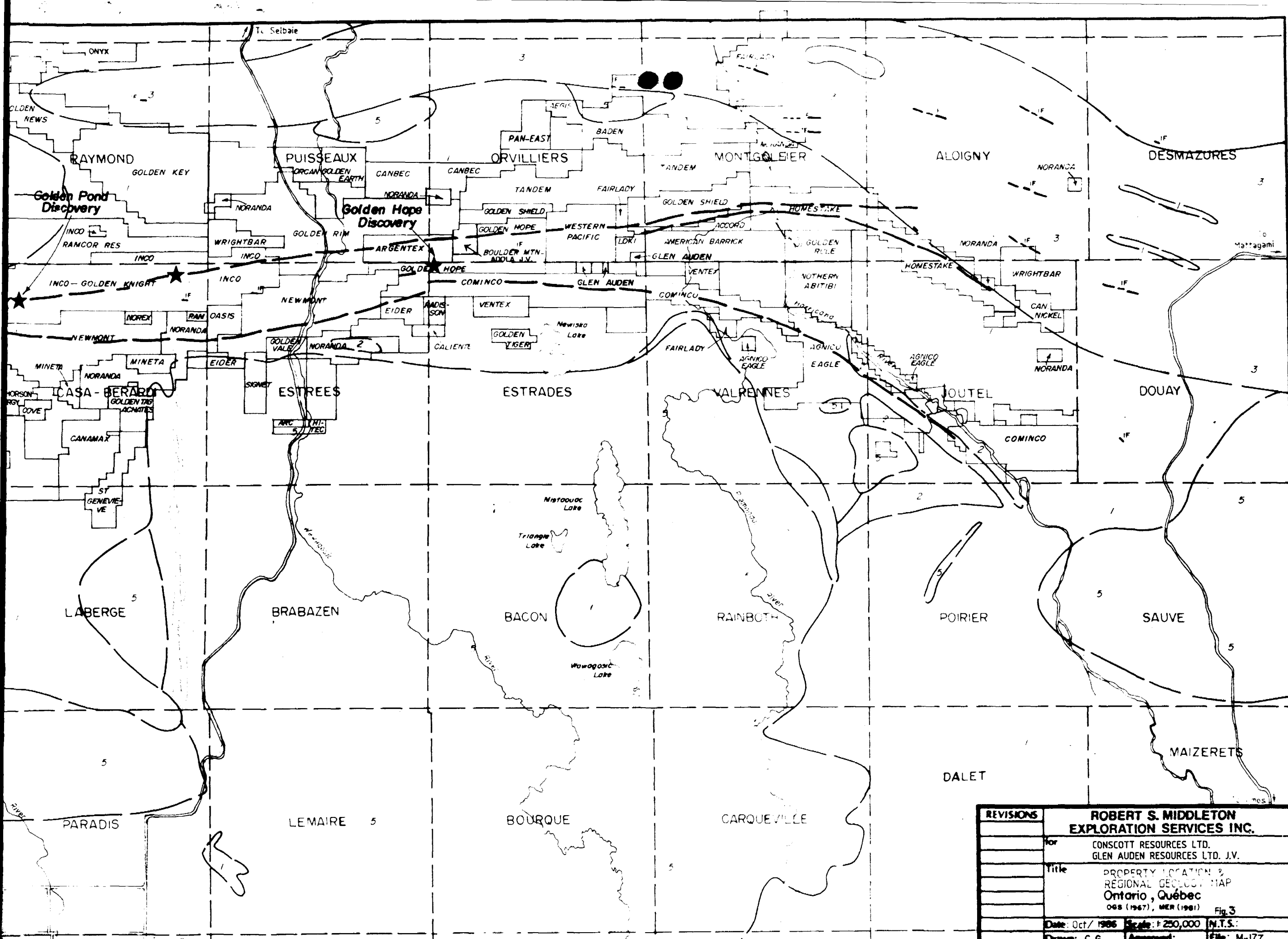

REVISIONS	ROBERT S. MIDDLETON EXPLORATION SERVICES INC.		
	for	CONSCOTT RESOURCES LTD. GLEN AUDEN RESOURCES LTD. J.V.	
	Title	PROPERTY LOCATION & REGIONAL GEOLOGY MAP Ontario, Québec OGS (1967), MER (1981) Fig. 3	
	Date:	Oct/1986	Scale: F 250,000 N.T.S.:
	Drawn:	C.G.	Approved: File: M-177

3. SURVEY OPERATIONS

3a. Survey Personnel

The survey crew was made up of experienced Questor employees:

Crew Manager/Data Technician	- Ken Sherk
Pilot/Captain of Aircraft	- Wayne Swantek
Co-pilot/Navigator	- Terry McConnell
Equipment Technician	- Ron Kasper
Aircraft Engineer	- Pat Melen

The flight path recovery was completed at the survey base, while the final data compilation and drafting was carried out by Questor at its Mississauga, Ontario office. The magnetic and electromagnetic processing was carried out using Questor software and computer drafted. The INPUT interpretation and report was completed by Marcel H. Konings, P.Eng.



3b. Instruments

A, Short Skyvan, C-GDRG, equipped with the following instruments was used for the survey:

1. Mark VI INPUT Electromagnetic System;
2. Geometrics G-813 Proton Magnetometer (1 gamma sensitivity);
3. Sonotek SDS 1200 Data Acquisition System;
4. RMS GR33 Analogue Recorder;
5. 35mm Camera, Intervalometer and Fiducial System;
6. Sperry Radar Altimeter.

A Geometrics G-816 Base Magnetometer was used to monitor the diurnal magnetic changes.

The equipment, such as the INPUT system, magnetometer and radar altimeter were regularly calibrated at the beginning and end of each survey flight as well as in mid-flight, whenever necessary. Details of the calibration procedures are given in Appendix C.

The continuous chart speed of the RMS recorder was set at 15 cm./minute.

3c. Production

The flight line spacing over the block was 100 metres.

Table 1 summarizes the kilometres flown during the survey operation.

Table 1

Traverse lines.....	212.88km
Control lines.....	1.4 km
Total lines.....	<u>214.28km</u>

The survey was completed in two production flights. No days were lost during the survey.

3d. Products

The products delivered by Questor, to Glen Auden Resources Limited, together with four copies of the report:

1. one unscreened master photo mosaic, scale 1:20,000;
2. one master photo mosaic with electromagnetic and magnetometer information and interpretation shown thereon, scale 1:20,000;
3. one magnetic overlay, scale 1:20,000;
4. one magnetic first derivative overlay, scale 1:20,000
5. four white prints of (2);
6. one computer plot of the electromagnetic and magnetometer flight analogues, scale 1:20,000;
7. one copy of colour contoured magnetics , scale 1:20,000;
8. one copy of colour contoured magnetic first derivative, scale 1:20,000;
9. the negative of the flight path film;
10. anomaly data sheets;
11. the flight logs.

### 3e. Survey Procedure

During the survey, the aircraft maintained a terrain clearance as close to 122 metres as possible, with the receiver coil (bird) at approximately 55 metres above the ground surface. In areas of substantial topographic relief and large population, the aircraft height may exceed 122 metres for safety reasons. The height of the bird above the ground is also influenced by the aircraft's air speed (see figure C1 in Appendix C), which was maintained at 110 to 120 knots, while on survey.

Whenever possible, the traverse lines were flown in alternate flight directions (e.g., north then south) to facilitate the interpretation of dipping conductors. When the traverse line

spacing exceeded twice the normal spacing interval over a 2.2 kilometre distance, the gap is normally filled with an appropriately spaced fill-in line at a later date.

The details of each production flight are documented on the flight logs by the equipment technician. The logs include the survey times, line numbers and fiducial intervals, as well as a record of equipment irregularities and atmospheric conditions. One may refer to these logs in order to relate the flight path film to the geophysical data.

During the course of the survey the following data were recorded:

1. INPUT Electromagnetic results represented by six channels of successively increasing time delays after cessation of the exciting pulse (Appendix A);
2. a record of the terrain clearance as provided by radar altimeter;
3. a photographic record of the terrain passing below the aircraft as obtained from a 35 mm. camera;
4. time markers impressed synchronously on the photographic and geophysical records to facilitate accurate positioning on photomosaics;
5. airborne magnetometer data;
6. ground base station magnetometer data.

3f. Magnetic Diurnal

Diurnal variations in the earth's magnetic field had been recorded to an accuracy of  $\pm 1$  nT using a base station equipped

with a Geometrics G-816 Proton Precession Magnetometer. It was monitored periodically during the day for severe diurnal changes (magnetic storms). A variation of 20 nT over a 5 minute time period was considered to be a magnetic storm. During such an event, the survey would normally have been discontinued or postponed and the survey data would have been scrubbed.

The base station magnetometer was set up at LaSarre, Quebec.

4b. Computer Processing

The completed flight path is accurately digitized on a flat-bed digitizer at Questor using the picked point co-ordinates. The recovery is then routinely verified by a computer programme 'speed check', which flags any abnormalities in the distance per fiducial unit between picked points on a traverse line. As a final check, the rough magnetic contour maps are examined for contour irregularities that could be attributed to recovery errors.

5. INPUT DATA PRESENTATION

The base maps for the survey area are photomosaics constructed from 1:50,000 air photographs supplied by Ontario Ministry of National Resources and taken in 1978. The photomosaic was used to construct the navigation flight strips and also the base onto which the flight path was recovered. The mosaics are uncontrolled at a scale of 1:20,000.

The INPUT anomaly map presents the information extracted from the analogue records. This consists chiefly of the peak anomaly positions and response characteristics, surficial responses, up-dip responses, and magnetic anomaly locations. In effect, these represent the primary data analysis. The symbols are explained in the map legend, but the following observations are presented:

- position of peak anomaly;
- conductance or conductivity-thickness;
- amplitude of channel 2 response;
- position and peak amplitude of associated magnetic anomalies;
- where present, surficial, up-dip and poorly defined responses have been identified with a unique symbol.

The interpretation maps outline the geophysical-geological interpretation of the INPUT electromagnetic, magnetic, geological and physiographic data. Bedrock conductors have axis locations and dip directions, when they are interpretable. The anomalous zones which are recommended for follow-up have a reference label assigned, to which additional comments and recommendations are

directed in the Interpretation Section of this report. Surficial response sources are mapped out by boundaries showing their interpreted lateral extent. The following list summarizes the interpretation presentation:

- bedrock conductor axis, probable and possible;
- conductor dip;
- surficial conductor outlines;
- anomalous conductors selected for ground evaluation with reference number.



6. INTERPRETATION - GENERAL

6a. Geological Perspective

The survey area is located in the western end of a major volcanic belt extending westward from Quebec. This part of the Abitibi belt contains mostly felsic to intermediate metavolcanics metamorphosed to greenschist and amphibolite facies. The area has been mapped by G.W. Johns in 1982 and documented in OGS Report 199. He suggests that the survey block is located within a volcanic pile which forms a domed feature. Although local folds have been suggested cutting across the felsics, this sequence appears to form a normal north facing pile with mafic volcanics to the south and metasediments dominating the lithology north of Bradette Township.

Drilling and outcrop mapping have established that volcanic sediments (tuffs and lapilli tuffs) dominate the lithology with flows being a very minor component. South of Rube Lake, very little mineralization has been established by previous drilling, while the northern part of the unit has been extensively explored and drilled.

6b. Conductivity Analysis

The conductivity-thickness products of planar horizontal, and thin steeply dipping conductors are proportional to the time constant of the secondary field electromagnetic transient decay. This transient may be closely approximated by an exponential function for which the conductivity-thickness product (TCP) is

INPUT INTERPRETATION

The main survey covered an area with 810 kilometers of flying covering several different exploration companies claims.

Glen Auden Resources Limited and Conscott Resources Ltd. hold a 92 claim property within the survey area, the results of which are shown on the map sheets at the back of this report (See Figures 3,4,5, Sheet 1).

The electromagnetic/magnetic survey covered a segment of the Burntbush greenstone belt which has not received previous evaluation. In addition to the strong conductors on which past exploration had focussed several weak (previously undetected) conductors were interpreted.

The 92 claim block of Glen Auden Resources Limited and Conscott Resources Ltd. covered by the Questor Survey is dominated by a highly magnetic feature striking southwest in the southern half of the claim block. Another strong magnetic high striking east-west is located in the northern half of the claim block.

There is also a strong magnetic feature striking east-west along the westcentral boundary of the claim block.

The survey block contains several bedrock conductors. It is highly recommended that all ground geochemical, geophysical and geological information be used in order to try and differentiate between graphite and sulfide-type responses.

Anomaly 73B

This moderate bedrock conductor is located along the edge of a linear southwest striking magnetic anomaly along the southern boundary of the claim block. The conductor is not associated directly with the magnetic high and may be reflecting mineralization along a contact.

Anomaly 10690S

This anomaly is the southwest extension of Anomaly 73B.

Anomaly 75C

These two strong conductors located in the eastcentral part of the claim block, are associated with a prominent magnetic high typical of an iron formation. This zone may have strike extensions to the southwest on line 10700N.

These anomalies probably reflect the presence of pyrrhotite within an iron formation.

Anomalies 10700N and 10810N, 10850N and 10890N

These moderate conductors in the southeast corner of the claim block, are striking east-north-east and may be the strike extension of Anomaly 75C. This zone is associated with a prominent magnetic high typical to an iron formation. These anomalies probably reflect the presence of pyrrhotite within an iron formation.

Anomaly 10600N

This moderate anomaly, located in the northwest corner of

the property, appears to reflect an isolated, weakly magnetic conductor. This zone could reflect possible sulfides and should be investigated on the ground.

Anomaly 10880S

This anomaly, located along the northern boundary of the property, appears to reflect an isolated, weakly magnetic conductor. This zone could reflect possible sulfides and should be investigated on the ground.

Depths were only determined for responses which appear to fit the interpretation model - a thin near vertical plate with a strike length of greater than 500 metres. Qualifications for these determinations are summarized in the interpretation section.

The depths for 5 and 6 channel anomalies were corrected for the interpreted conductor strike intersection relative to the line direction and the effects of aircraft altitude deviations from a flight altitude of 120 metres.

An anomaly listing at the back of this report summarizes each anomalous response in a numerical sequence. In addition to the standard anomaly parameters, an "anomaly type" classification has been added. The letters correlate with the plotted symbols according to the following table.

<u>ANOMALY TYPE</u>	<u>RESPONSE SOURCE</u>	<u>SYMBOL</u>
BLANK	bedrock conductors	circular
S	surficial (overburden or lakebottom) conductivity	diamond
U	up-dip accessory peak to main response	half circular, half diamond, symbolically "pointing" in dip direction
P	poorly defined response	asterisk "*" in lower left quadrant
C	cultural source	square

The "P" poorly defined response may not yield signatures diagnostic of a discrete bedrock anomaly to standard electromagnetic prospecting equipment. Interpreted axis locations may be approximate for these intercepts.

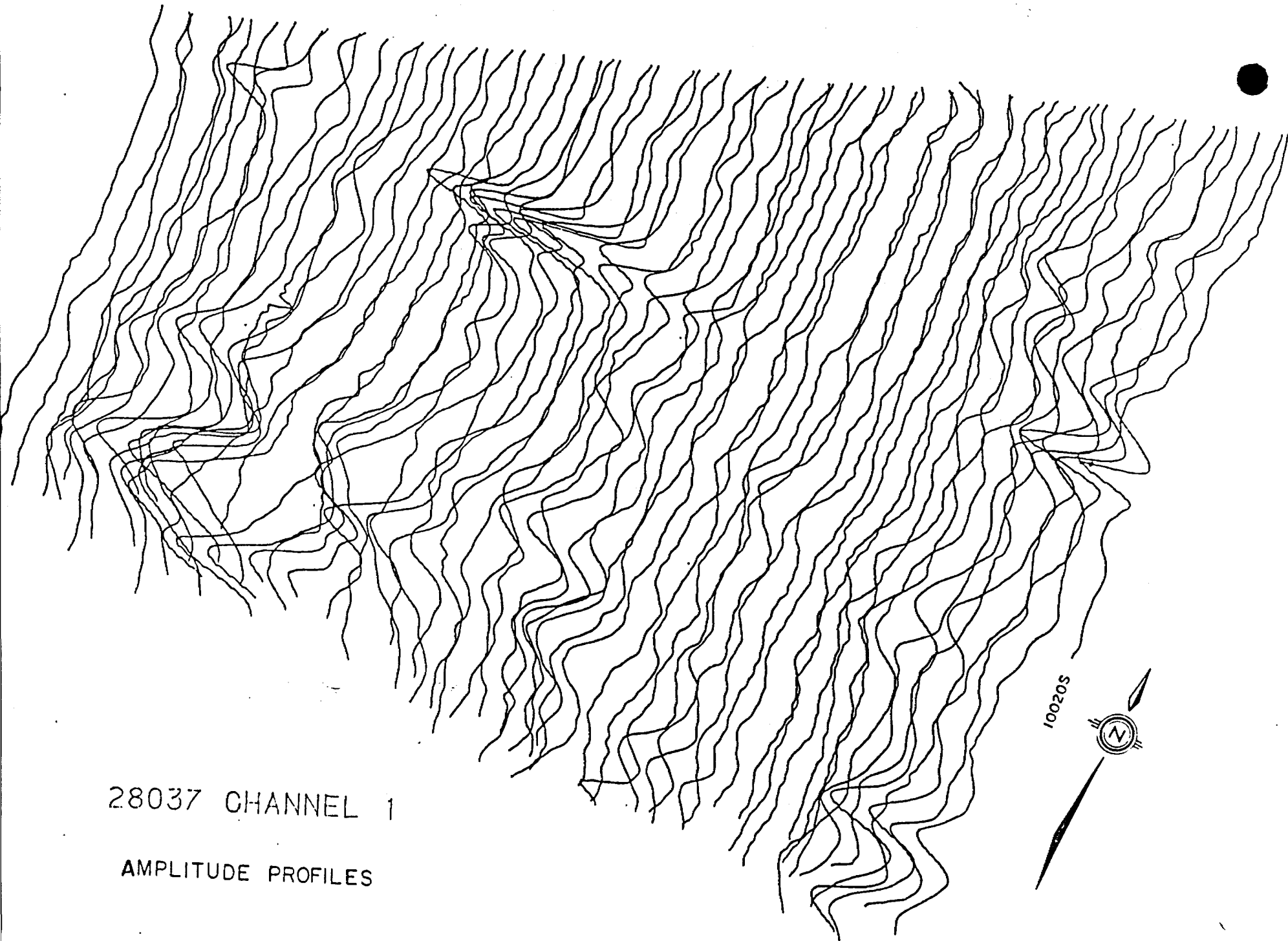

28037 CHANNEL 1

AMPLITUDE PROFILES

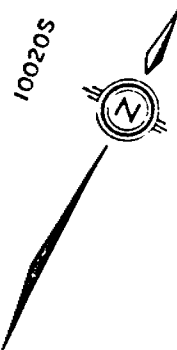

## INPUT System Characteristics

The INPUT receiver sensor is towed approximately 93 metres behind and 68 metres below the aircraft at a survey airspeed of 110 knots. The actual position of the bird is dependent on the airspeed of the survey aircraft, as can be seen in Figure A1. For the Trislander, Skyvan and DC-3 aircrafts, airspeeds average 110 knots.

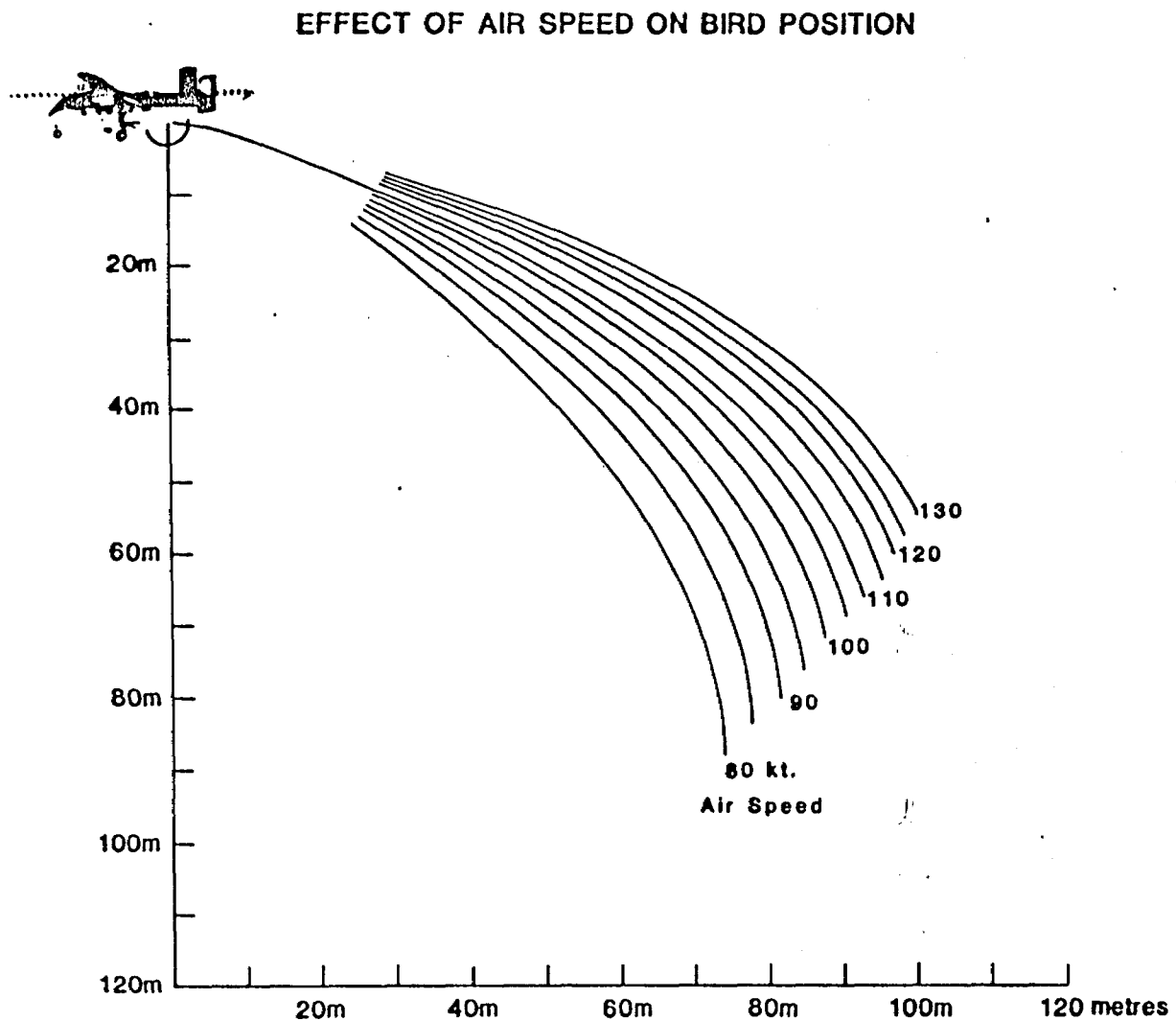

Figure A1



INPUT TRANSMITTER SPECIFICATIONS

Pulse Repetition Rate	180 pps.
Pulse Shape	half-sine
Pulse Width	2.0 ms.
Off Time	3.56 ms.
Output Voltage	75 V.
Output Current	240 A.
Output Current Average	54 A.
Coil Area	186 m. <sup>2</sup>
Coil Turns	6
Electromagnetic Field Strength (peak)	267,840 amp-turn-meter <sup>2</sup>

INPUT SIGNAL  
TRANSMITTED PRIMARY FIELD

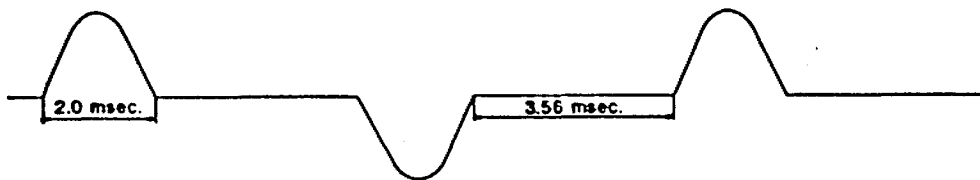

Figure A2

INPUT RECEIVER SPECIFICATIONS

Sample Gate	Windows (centre positions)	Widths
CH 1	300 $\mu$ sec.	200 $\mu$ sec.
CH 2	500	200
CH 3	800	400
CH 4	1200	400
CH 5	1700	600
CH 6	2300	600

Integration Time Constant 1.2 sec.

Receiver Features: Power Monitor 50 or 60 Hz  
 50 or 60 Hz (and harmonic) Filter  
 VLF Rejection Filter  
 Spheric Rejection (tweak) Filter

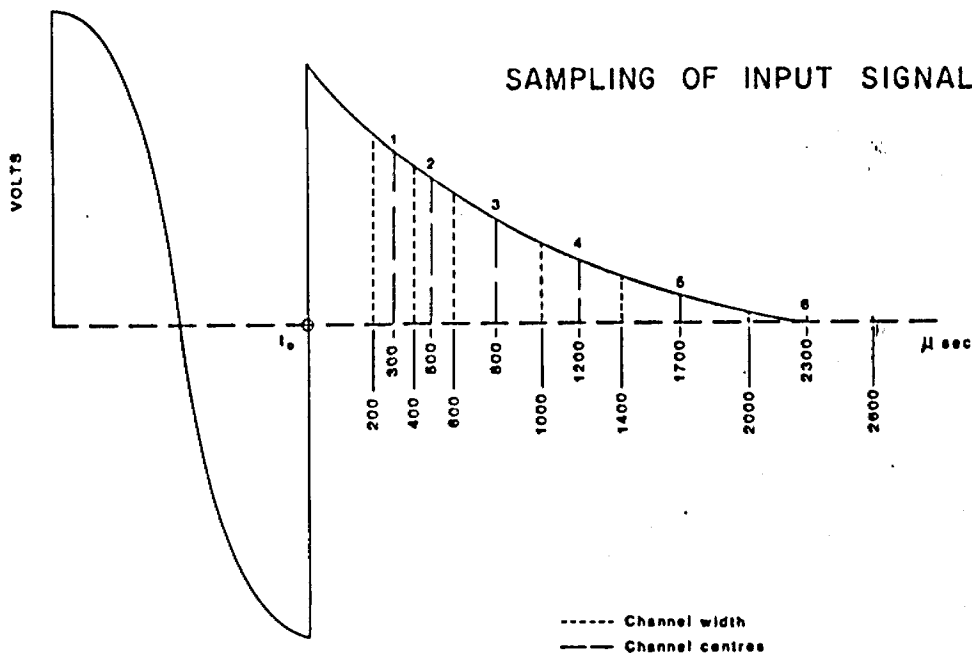

Figure A3

DATA ACQUISITION SYSTEM

Sonotek SDS 1200

Includes time base Intervalometer, Fiducial System

CAMERA

Geocam 75 SF

35 mm continuous strip or frame

TAPE DRIVE

DIGIDATA MODEL 1139

9 TRACK 800 BBI ASCII

OSCILLOSCOPE

Tektronix Model 305

ANALOGUE RECORDER

RMS GR-33

Heat Sensitive Paper (33cm)

Recording 10 Channels: 50-60 Hz Monitor, 6 INPUT Channels, fine and coarse Magnetics and Altimeter. Also, time, fiducial numbers, latitude and longitude (optional), timing lines, centimetre spaced vertical scale marks and line numbers are imprinted on the paper.

ALTIMETER

Sperry Radar Altimeter

## GEOMETRICS MODEL G-813 PROTON MAGNETOMETER

The airborne magnetometer is a proton free precession sensor which operates on the principle of nuclear magnetic resonance to produce a measurement of the total magnetic intensity. It has a sensitivity of 0.1 gamma and an operating range of 17,000 gammas to 95,000 gammas. The G-813 incorporates fully automatic tuning over its entire range with manual selection of the ambient field starting point for quick startup. The instrument can accurately track field changes exceeding 5,000 nT and for this survey has an absolute accuracy of 0.5 nT at a 1 second sample rate. The sensor is a solenoid type, oriented to optimize results in a low ambient magnetic field. The sensor housing is mounted on the tip of the tail boom supporting the INPUT transmitter cable loop. A 3 term compensating coil and perma-allow strips are adjusted to counteract the effects of permanent and induced magnetic fields in the aircraft.

Because of the high intensity electromagnetic field produced by the INPUT transmitter, the magnetometer and INPUT results are sampled on a time share basis. The magnetometer head is energized while the transmitter is on, but the read-out is obtained during a short period when the transmitter is off. Using this technique the sensor head is energized for 0.80 seconds and subsequently the precession frequency is recorded and converted to gammas during the following 0.20 second when no current pulses are induced into the transmitter coil.

## APPENDIX B

### THE SURVEY AIRCRAFT

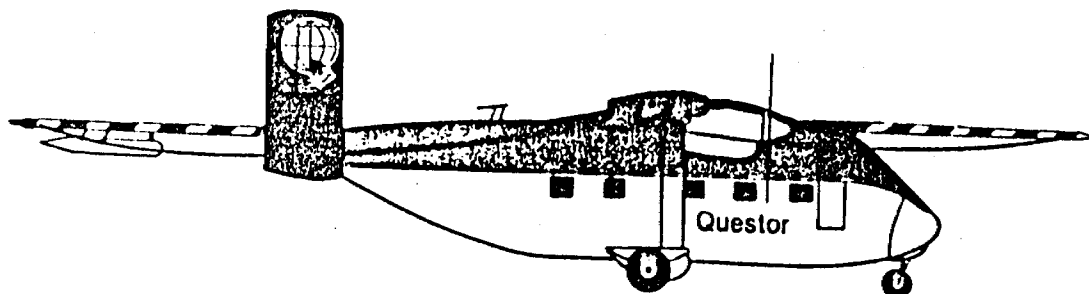

Figure B1

Manufacturer	Short Brothers Ltd.,
Type	SHORT SKYVAN
Model	SH-7 Series 3
Canadian Registration	C-GDRG
Dat of INPUT Installation	October 1981

#### Modifications:

- 1) Nose, tail and wing booms for coil mounting;
- 2) Long range cabin fuel tank: 8 hours of air time;
- 3) Winch, camera and altimeter ports;
- 4) Sperry C-12 navigational system;
- 5) Doppler navigational system (optional);
- 6) Capable of spectrometry;
- 7) Modified hydraulic driven generator system.

The SKYVAN is a short take-off and landing aircraft. It is powered by two low maintenance turbine engines. The configuration of the aircraft provides for easy installation of equipment and extra fuel capability. These factors have made the SKYVAN a reliable and efficient geophysical survey aircraft.

## APPENDIX C

### CALIBRATION OF THE SURVEY EQUIPMENT

The major advance made during the transition from the INPUT MK V to the MK VI Model has been the ability to calibrate the equipment accurately and consistently.

At the beginning of each survey flight, the calibration of the survey equipment is performed by the following tests:

- 1) zero the 6 channel levels;
- 2) altimeter calibration;
- 3) calibration of INPUT receiver gain;
- 4) aircraft compensation;
- 5) record background E.M. levels at 600m;

This sequence of tests are recorded on the analogue records and may be repeated in midflight given that the duration of the flight is sufficiently long (Figure C1). At the termination of every flight, the calibration of the equipment is checked and recorded for any drift that may have occurred during the flight.

Channels 1 to 6 are zeroed on the analogue record by first placing the INPUT receiver into calibration mode, which isolates the receiver from any bird signal. Then, the channels are adjusted so that they are evenly spaced 5mm. apart with channel 6 positioned on the first half cm. line at the top of the record.

Compensation is the technique by which the effects of the noise are minimized. A reference signal obtained from the primary field at the receiver coil is utilized to compensate each channel of the receiver for coupling differences caused by bird motion relative to the aircraft. This signal is proportional to the inverse cube of the distance between the bird and aircraft.

Compensation procedures are carried out at an altitude of 600 metres in order to eliminate the influence of external

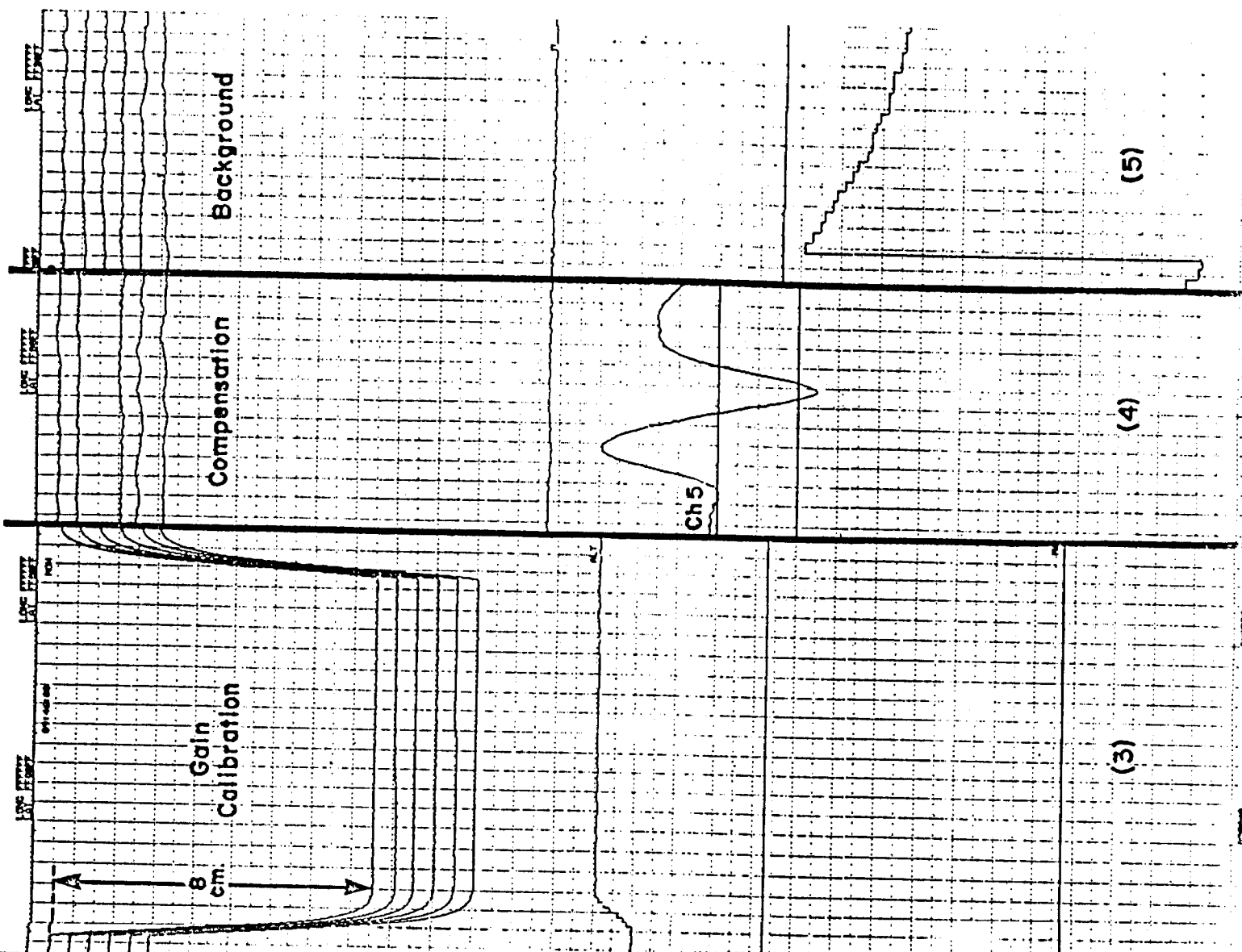

## TIME CONSTANT OF THE INPUT SYSTEM

The time constant, is defined as the time for a receiver signal (voltage) to build up or decay to 63.2% of its final or initial value. A longer time constant reduces background noise but also has the effect of reducing the amplitude of a signal as well as the resolution of the system. A time constant of 1.1 sec. has been found to be the optimum value.

The time constant is periodically verified for continuity. It can be measured from the exponential rise or decay of the calibration signal, recorded during the calibration of the receiver gain (figure C1,(3)).



## THE LAG FACTOR

The bird's spatial position, along with the time constant of the system, introduces a lag factor (Figure C2) or shift of the response past the actual conductor axis in the direction of the flight line. This is due to fiducial markers being generated and imprinted on the film in real time and then merged with E.M. data which has been delayed due to the two aforementioned parameters. This lag factor necessitates that the receiver response be normalized back to the aircraft's position for the map compilation process. The lag factor can be calculated by considering it in terms of time, plus the elapsed distance of the proposed shift and is given by:

$$\text{Lag (seconds)} = \text{time constant} + \frac{\text{bird lag (metres)}}{\text{ground speed (metres/sec)}}$$

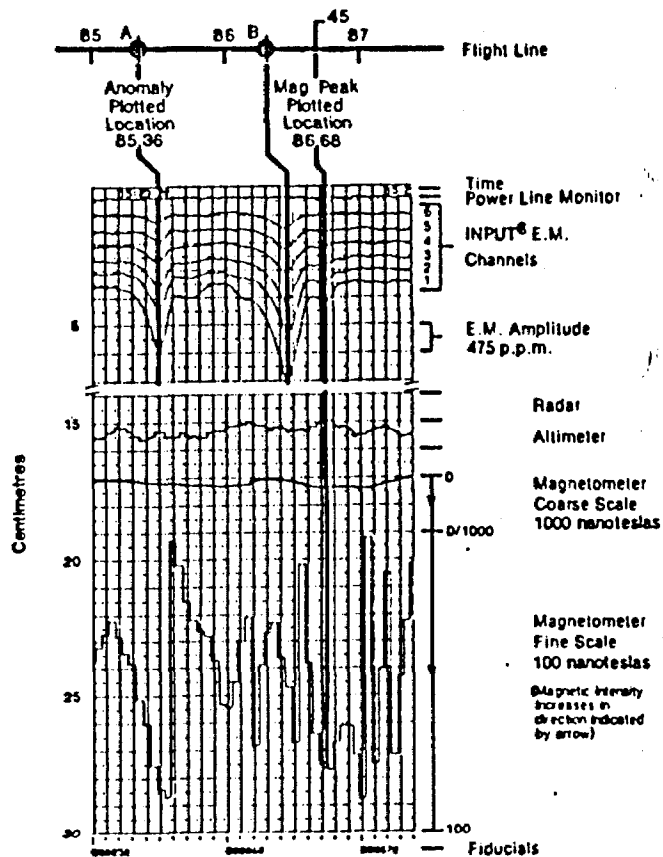

The time constant of the system introduces a 1.1 second lag while, at an aircraft velocity of 110 knots, the 'bird' lag is 1.7 seconds. The total lag factor which is to be applied to the INPUT E.M. data at 110 knots is 2.8 seconds (1.4 fiducials). It must be noted that these two parameters vary within a small range dependent on the aircraft velocity, though they are applied as constants for consistency. As such, the removal of this lag factor will not necessarily position the anomaly peaks directly over the real conductor axis. The offset of a conductor response peak is a function of the system and conductor geometry as well as conductivity.

The magnetic data has a 1.0 second lag factor introduced relative to the real time fiducial positions. This factor is software controlled with the magnetic value recorded relative to the leading edge (left end) of each step 'bar', for both the fine and coarse scales. For example, a magnetic value positioned at fiducial 10.00 on the records would be shifted to fiducial 9.95 along the flight path.

A lag factor of 2 seconds (1.0 fiducial) is introduced to correct 50-60 Hz monitor for the effects of bird position and signal processing. In cases where a 50-60 Hz signal is induced in a long formational conductor, a 50-60 Hz secondary electromagnetic transient may be detected as much as 5 km. from the direct source over the conductive horizon.

The altimeter data has no lag introduced as it is recorded in real time relative to the fiducial markings.

## APPENDIX D

### INPUT DATA PROCESSING

The QUESTOR designed and implemented computer software for automatic interactive compilation and presentation, may be applied to all QUESTOR INPUT Systems. Although many of the routines are standard data manipulations such as error detection, editing and levelling, several innovative routines are also optionally available for the reduction of INPUT data. The flow chart on the following page (Figure D1) illustrates some of the possibilities. Software and procedures are constantly under review to take advantage of new developments and to solve interpretational problems.

#### a) INPUT Data Entry and Verification

During the data entry stage, the digital data range is compared to the analogue records and film. The raw data may be viewed on a high-resolution video graphics screen at any desirable scale. This technique is especially helpful in the identification of background level drift and instrument problems.

#### b) Levelling Electromagnetic Data

Instrument drift, recognized by viewing compressed data from several hours of survey flying, is corrected by an interactive levelling program. Although only two or three calibration sequences are normally recorded, levelling can be

## INPUT PROCESSING

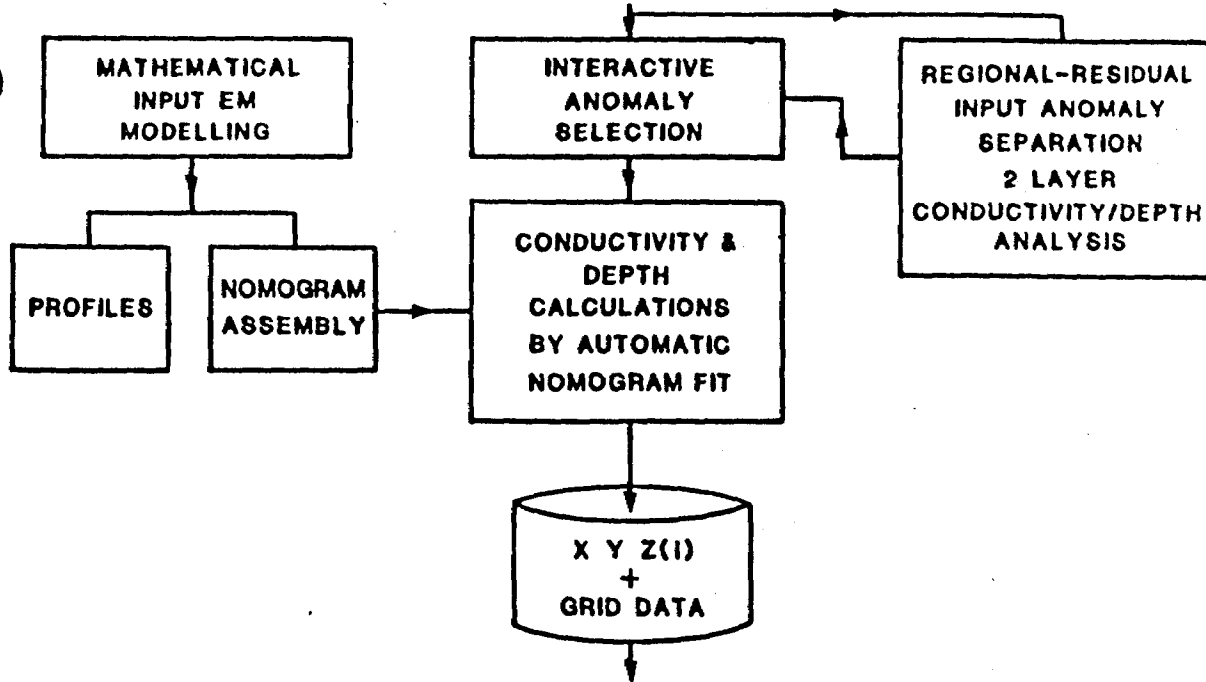

## MAGNETIC GRID INTERPOLATION AND DEVELOPMENT



## MAGNETIC PROCESSING

TWO DIMENSIONAL SPATIAL FILTERING	DECORRUGATION	DEPTH TO LAYERS	SUSCEPTIBILITY MAPPING
	HIGH, LOW BAND PASS	DERIVATIVES	USER DEFINED FREQUENCY DOMAIN PROCESS
	UPWARD/DOWNWARD CONTINUATION	REDUCTION TO THE POLE	

## DISPLAY

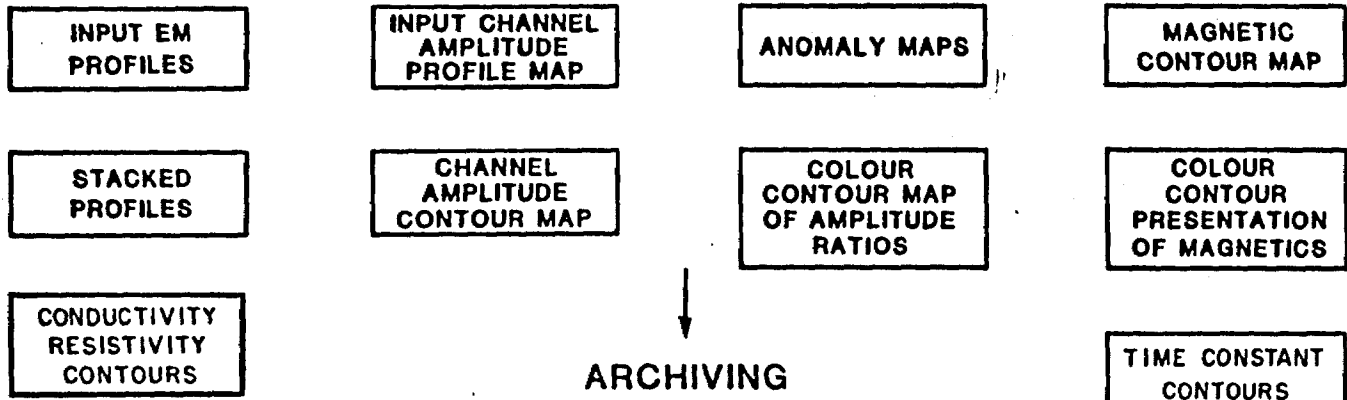

## ARCHIVING

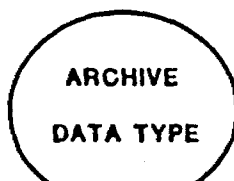

## APPENDIX E

### INPUT INTERPRETATION PROCEDURES

In the analysis of INPUT responses, the following parameters are considered:

a) Anomaly Characteristics

- amplitude, number of channels, decay rate, symmetry;
- half width and the overall relationships to adjacent and along strike responses, plus the ground-to-aircraft distance.

b) Geological Relationships

- known geological strike and dip patterns;
- host rock, overburden and saprolite conductivity.

c) Cultural Relationships

- as directed by the power line monitor;
- correlation with known features such as buried pipelines, fence lines, farm and industrial buildings, etc.

For each anomaly selected the following are documented:

- line number and anomaly letter;
- fiducial location on line;
- interpreted source type of the anomaly - bedrock, surficial, cultural;
- number of channels of response;
- amplitudes in parts-per-million of channels 1 through 6;
- apparent conductance in siemens based on the appropriate source model;

- corresponding magnetic association in nanoTeslas with fiducial location;
- altitude (ground-to-aircraft) in metres.

From the anomaly characteristics, interpretative aspects such as up-dip responses, dip direction and altitude are made. Anomalies are then grouped into linear trends for bedrock conductors, and zones for horizontal conductivity contrasts, by correlation with adjacent on-strike responses.

Also, the interpreted source of the INPUT response is categorized as bedrock, surficial, accessory (up-dip) or cultural.

Bedrock conductors are caused by massive sulphides, graphite bearing formations, serpentized peridotites and in some instances by faults or shear zones. Magnetite concentrations may also, in some circumstances, yield anomalous INPUT responses. INPUT responses have been well documented by Macnae (1979), and Palacky and Sena (1979).

#### MASSIVE SULPHIDE DEPOSITS

The conductivity characteristic of massive sulphides is due to intergranular connections forming elongated sheet-like masses which permit the induction of eddy currents. These produce a secondary electromagnetic field which can be detected and quantitatively measured.

In most sulphide bodies the conductivity is caused by pyrrhotite and chalcopyrite. Pyrite, which often forms the greater quantity of sulphides present, usually occurs as isolated, albeit

closely spaced grains or crystals, and therefore, only produces moderate or weak responses. Sphalerite does not provide anomalous responses and can even insulate the better sulphide conductivity portion of a deposit. The resultant overall conductivity response from a massive sulphide deposit is in the range of 5 to 30 Siemens/metre, although individual lenses or mineral aggregates may have much higher conductivities.

Massive sulphide deposits occur as injections, veins and stratiform bodies of variable size, geometry and conductivity. Given these variables, there are no universal rules for all sulphide deposits; however, there are some general observations regarding the INPUT responses. These are:

- Amplitudes primarily increase in response to conductor strike and depth extent up to an "infinite" size of some 600 metres by 300 metres. Thereafter, source conductor width contributes to amplitudes, that is, amplitude is dependant on sulphide mass.
- Conductance varies independantly with the overall integrated mineralogy and form of the sulphide components.

INPUT is often utilized in the search for volcanogenic copper-zinc sulphide deposits. These deposits are usually associated with felsic volcanic sequences, often at the interface of felsic-mafic rocks or with intercalated tuffs and/or sedimentary rocks. Many of these deposits have stringer sulphide zones in the footwall rocks related to feeder vent alteration systems and these can also contribute to the INPUT response. Laterally, the main sulphide deposits can lens out quickly or continue as minor bands, lenses or disseminated sulphides within more regionally extensive coeval tuffs or sediments and also provide INPUT responses along a considerable strike extent. All these variables must be considered in the explorationist's depositional model and in the analysis and interpretation of the geophysical responses. A careful analysis of the conductances, apparent widths (half peak width) and magnetic responses will often reveal the geometry-source aspects of the deposit. Stratiform base metal sulphides of up to 2,000 metres strike extent are known, although most sizeable deposits have strike lengths between 500 and 1,000 metres.

The magnetic response of a sulphide deposit is the most deceiving information available to the explorationist. Although many large economic deposits have a strong direct magnetic association, some of the largest base metal deposits have no magnetic association. Others have flanking magnetic anomalies caused by pyrrhotite/magnetite deposits in volcanic vent systems flanking the main sulphide body. Essentially non-homogeneous conductivities and magnetic responses may be favourable parameters.



## GRAPHITIC SEDIMENTARY CONDUCTORS

Graphitic sediments are usually found within the sedimentary facies of greenstone belts. These represent a low energy, subaqueous sedimentary environment. Graphites are often located in basins of the subaqueous environment, producing the same geometrical shape as sulphide concentrations. Most often however, they form long, homogeneous planar sequences. These may have thicknesses from a metre to hundreds of metres. The recognition of graphite in this setting is often straightforward because conductivities and apparent widths may be very consistent along strike. Strike lengths of tens of kilometres are common for individual horizons.

The conductivity of a graphite formation is a function of two variables:

- a) the quality and quantity of the graphite, and
- b) the presence of pyrrhotite as an accessory conductive mineral

Pyrite is the most common sulphide mineral occurring within graphitic sequences. It does not contribute significantly to the overall conductivity as it will normally be found as disseminated crystals. Amphibolite facies metamorphism will often be sufficient to convert carbonaceous sediments to graphitic beds. Likewise, pyrite will often be transformed to pyrrhotite.

Without pyrrhotite, most graphitic conductors have less than 10 S conductivity-thickness value as detected by the INPUT system or 1 to 10 S/m conductivity from ground geophysical measurements. With pyrrhotite content, there may be little difference from other sulphide conductors.

It is not unusual to find local concentrations of sulphides within graphitic sediments. These may be recognized by local increases in apparent width, conductivity or as a conductor offset from the main linear trends.

Graphite has also been noted in fault and shear zones which may cross geological formations at oblique angles.

#### SERPENTINIZED PERIDOTITES

Serpentinized peridotites are very distinguishable from other anomalies. Their conductivity is low and is caused partially by serpentine. They have a fast decay rates, large amplitudes and strong magnetic correlation. Large profile widths with a shape similarity to surficial conductors are a common characteristic.

#### MAGNETITE

INPUT anomalies over massive magnetites correlate to the total Fe content. Below 25-30% Fe, little or no response is obtained. However, as the Fe percentage increases, strong anomalies may result with a rate of decay that usually is more pronounced than those for massive sulphides.

Negative INPUT responses may occur in a resistive but very magnetic iron formation, the result of a very high permeability, however, these are extremely rare.

### SURFICIAL CONDUCTORS

Surficial conductors are characterized by fast decay rates and usually have a conductivity-thickness of 1-5 siemens. This value is much higher in saline conditions. Overburden responses are broad, more so than bedrock conductors. Anomalies due to surficial conductivity are dependent on flight direction. This causes a staggering effect from line-to-line as the INPUT response is much stronger for the leading edge of the flat lying surface materials than for the trailing edge. When the surficial response has the form of a thin horizontal ribbon, anomalies may be very difficult to distinguish from weak bedrock conductors. A unique identification for all geometries of horizontal ribbon, sheet and layer conductivity contrasts is best accomplished by matching of transient decay amplitudes to the appropriate response nomogram.

### CULTURAL CONDUCTORS

Cultural conductors are identifiable by examining the power line monitor and the film to locate railway tracks, power lines, buidings, fences or pipe lines. Power lines produce INPUT anomalies of high conductivity that are similar to bedrock responses. The strength of cultural anomalies is dependent on the grounding of the source. INPUT anomalies usually lag the power line monitor by 1 second, which should be consistent from line-to-line. If this distance between the INPUT response and the power line monitor differs between lines, then there is the

possibility of an additional conductor present. The amplitude and conductivity-thickness of anomalies should be consistent from line-to-line.

## APPENDIX F

### INPUT RESPONSE MODELS

To the interpreter, one of the main advantages of the INPUT system geometry is the variation of the secondary response with conductor shape, size, depth and conductivity (Palacky 1976, 1977).

When we discuss the recognition parameters, one of the variables which is often omitted, is the plotting position of the main peaks in opposite flight directions on adjacent lines. In many cases, the responses may appear similar, but the plotting positions will show significant differences. These situations will be illustrated in the following section.

A third conductor identification factor is the INPUT decay transient for the main response peak. The decays may be used to identify the type of source, independent of the geometrical response which is dependent on the mutual coupling.

The interpreted conductor axis location varies with the source dip, conductivity, depth, thickness, depth extent and angle of intersection of the flight line to the conductor (strike direction).

The response of a cylinder may be quite difficult to recognize from a thin strip. A cylinder or spherical model does not show a pronounced negative or upward peak following the main response. Due to the effect of the time constant of the INPUT receiver, the negative peaks which follow the theoretical response do not appear on the INPUT records (Mallick 1972, Morrison et al 1969). As the illustrations show, the sphere-cylinder response is perfectly symmetrical, but not centered over the body. The plotting position of the main peak leads the actual axis location because the most favourable mutual coupling occurs just before the transmitter coil passes the conductive body. The amplitude of the responses will be similar in both flight directions for a perfect cylinder.

c) THE HORIZONTAL SHEET

economic - some stratabound massive sulphides;  
- regolith conductivity alteration haloes over  
some uranium deposits;

non

economic - overburden, lateritic soils;  
- weathered rock;  
- sea water or saline formations;  
- graphitic metasediments.

THE HORIZONTAL SHEET

FLIGHT DIRECTION

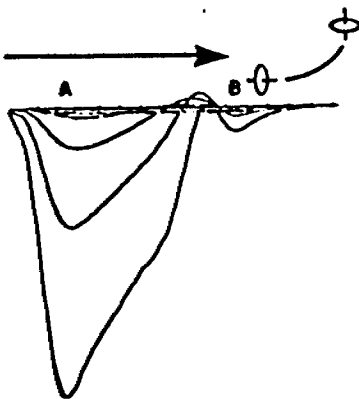

REVERSE FLIGHT DIRECTION

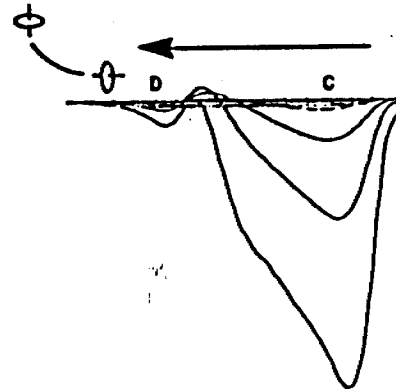

ANOMALY MAP PRESENTATION

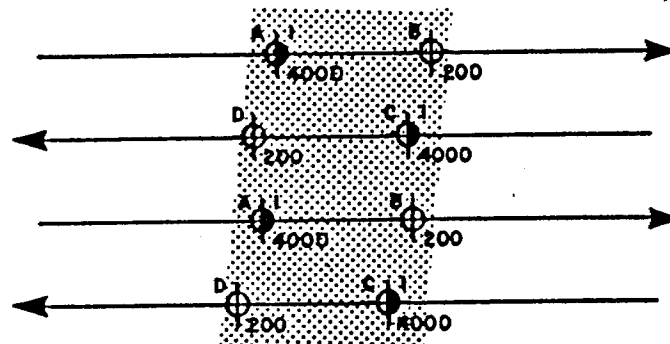



The horizontal conducting sheet has many variations but it is essentially simple to recognize. The amplitudes of the earlier channels may reach 30,000 ppm where saline solutions are present, however, horizontal sheet responses of channels 4, 5 and 6 attenuate, more rapidly than for a vertical or steeply dipping plate.

The edge effect is a common interpretational problem where a conductive layer is encountered. A secondary peak may occur as the receiver coil crosses the trailing edge of the layer. These responses are always very sharp and often have very high apparent conductivities.

The edges of the sheet are positioned approximately at the half-peak width positions which are usually the inflection points of the profile.

The variations in plotting positions observed for dipping sheets are not as evident for the plate.

It is not unusual to see a shift in the peaks, with the latter channels migrating towards a section of improved conductance and/or increasing thickness. Another characteristic of poorly conducting sheets which respond only on channels 1 through 4 is the inversion of responses on channels 5 and 6. This is a reaction of the compensation circuits to changes in the primary field in the presence of a strong conductor and it serves no practical end except as a recognition aid.

The horizontal sheet model also applies to residual soils or laterite as well as conducting rock units. As the thin overburden situation changes to a thick overburden or two layer case and finally to a half space or a uniformly conductive earth, the responses also vary. The latter cases will have progressively broader responses which would seldom be mistaken for true discrete conductive zones.

When flight lines in opposite directions cross a conductive sheet, an asymmetric mirror image response occurs when the sheet is uniform. If there are variations in the geometry or conductance across the sheet, it may be necessary to compare responses with a shallow dipping sheet conductor to determine the effects, which would not be similar when compared with adjacent lines.

d) THE VERTICAL STRIP (RIBBON) RESPONSE

non

economic - rarely encountered in nature;

cultural - grounded hydro lines, lightning arrestor lines,  
fences.

THE VERTICAL STRIP (RIBBON) RESPONSE

FLIGHT DIRECTION

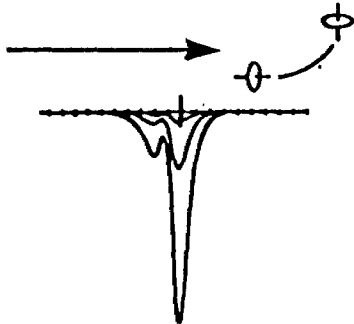

REVERSE FLIGHT DIRECTION

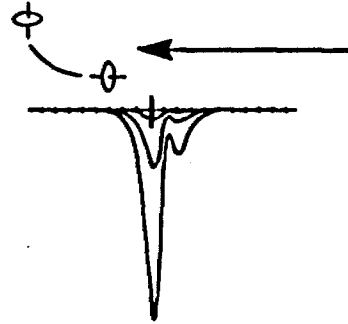

ANOMALY MAP PRESENTATION

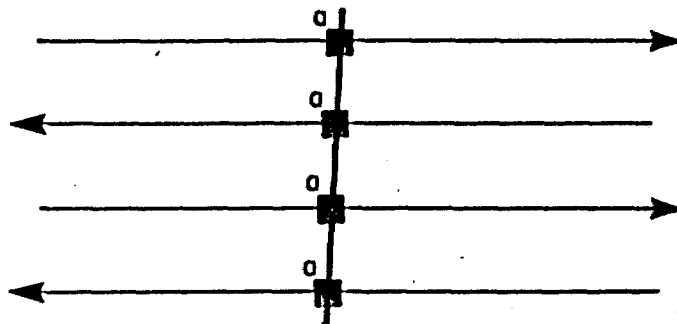

Due to the fact that this type of response is most commonly caused by fences, lightning protection lines and grounded power lines, the customary cultural presentation is a square symbol. This cultural response symbol may or may not have a power monitor (50-60 cycle) response but these will normally follow pipelines, fences, power lines, roads, railroads and other man made structures. The amplitude and apparent conductivity of such responses varies with the ground conductivity. In residual soils or conductive overburden, it is often possible to see a positive (up-dip type) peak followed by a small negative immediately before the main conductive response. The presence and amplitudes of such responses is normally very consistent. The cause of such responses is interpreted to be current gathering within the surficial sediments (West and Macnae 1982).

e)

### THE HORIZONTAL STRIP (RIBBON) RESPONSE

economic - some stratabound massive sulphides;

non

economic - some stratabound mineral deposits;

geological- weathering of narrow basic rock units with a  
high amphibolite content;

cultural - grounded and interconnected fences, pipes.

### THE HORIZONTAL STRIP (RIBBON) RESPONSE

FLIGHT DIRECTION

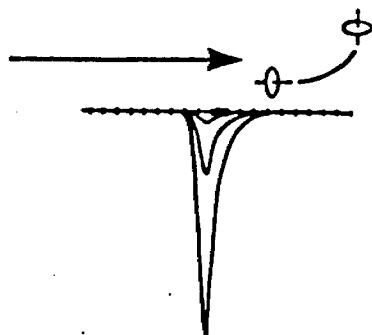

REVERSE FLIGHT DIRECTION

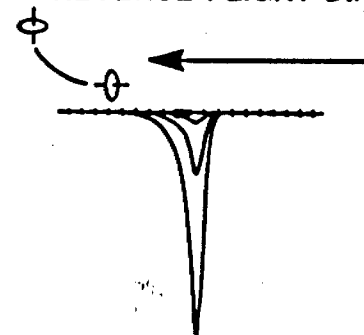

### ANOMALY MAP PRESENTATION

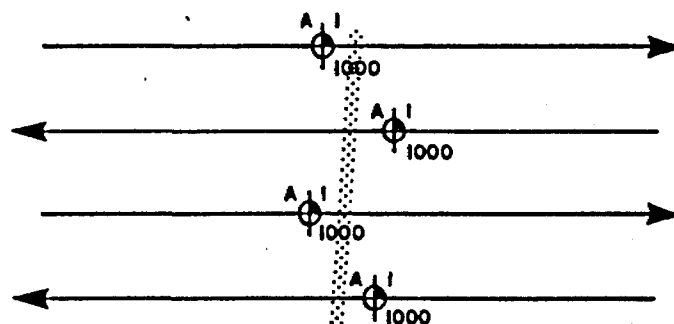

The plotting positions of the responses could easily be mistaken for a vertical plate conductor, however, careful consideration must be given to the flight direction. The horizontal ribbon is a degeneration of the horizontal conducting sheet. It can be easily distinguished from a sphere or cylindrical body by its peak asymmetry, whereas the sphere model has a single symmetric main response.

## APPENDIX G

### QUANTITATIVE INTERPRETATION

The quantitative interpretation of the INPUT data is normally accomplished by comparing the resultant responses with type curves obtained from theoretical calculations, scale model studies and actual field measurements. A variety of results are available in literature for different conductor geometries and system configurations (see Ghosh 1971, Palacky 1974, Becker et al., 1972, Lodha 1977, Ramani 1980). They have also examined the effects of varying such parameters as conductance, conductor depth, dip and depth extent. Their approach has been successfully applied in interpretation of past field surveys.

The nomograms which are currently available for the INPUT system are the Vertical Half-Plane, Homogeneous Half-Space, Thin Overburden and  $135^{\circ}$  Dipping Half-Plane nomograms. The first is particularly useful for the interpretation of vertical dyke-like conductors frequently found in the Precambrian Shield type environments. In the case of a thick, homogeneous, flat-lying (less than 30 dip) source, the Homogeneous Half-Space nomogram should be applied. While in a thin overburden or tropically weathered rock environment, the Thin Overburden nomogram may be referenced to determine the depth and conductance of the overburden (Palacky and Kadokaru, 1979).

As an example, INPUT anomalies due to vertical dyke-like conductors, are asymmetric and independent of the flight direction.

Their shape is characterized by a minor first peak and a major second peak and their channel amplitudes are a function of the conductivity-thickness product and depth of the source. Anomaly B in Figure G1 illustrates one of these responses.

The channel amplitudes of anomaly A can be used in quantitative interpretation in the following way. Their values are plotted for each of the six channels on logarithmic (5 cycles K+E 46 6213) tracing paper in a straight line using the vertical logarithmic scale in parts per million as given on the right side of Figure G2. The six channel amplitudes for anomaly A, in ppm, are 1657, 1108, 821, 500, 356, 237, respectively. The amplitudes are measured in ppm (1cm = 475 ppm) from the flight records with reference to the normal background levels on respective channels. Those responses which do not provide at least three channels of deflection, or whose first channel amplitude is less than 50 ppm over the normal background, should not be subjected to this analysis. The six points on the semi-logarithmic paper are then fitted to the curves of the vertical half-plane nomogram (Figure G2) without any rotation. Having accomplished this, the lateral placement of the plot indicates the apparent conductivity-thickness value, in siemens, and the position of the 10,000 ppm line on the logarithmic paper indicates the conductor depth, in metres. In the example shown (Figure G2), the apparent conductivity-thickness value is 50 siemens and the depth is 30 metres.



FIXED WING 2ms PULSE  
VERTICAL 600m x 300m PLATE  
CONDUCTANCE / DEPTH NOMOGRAM

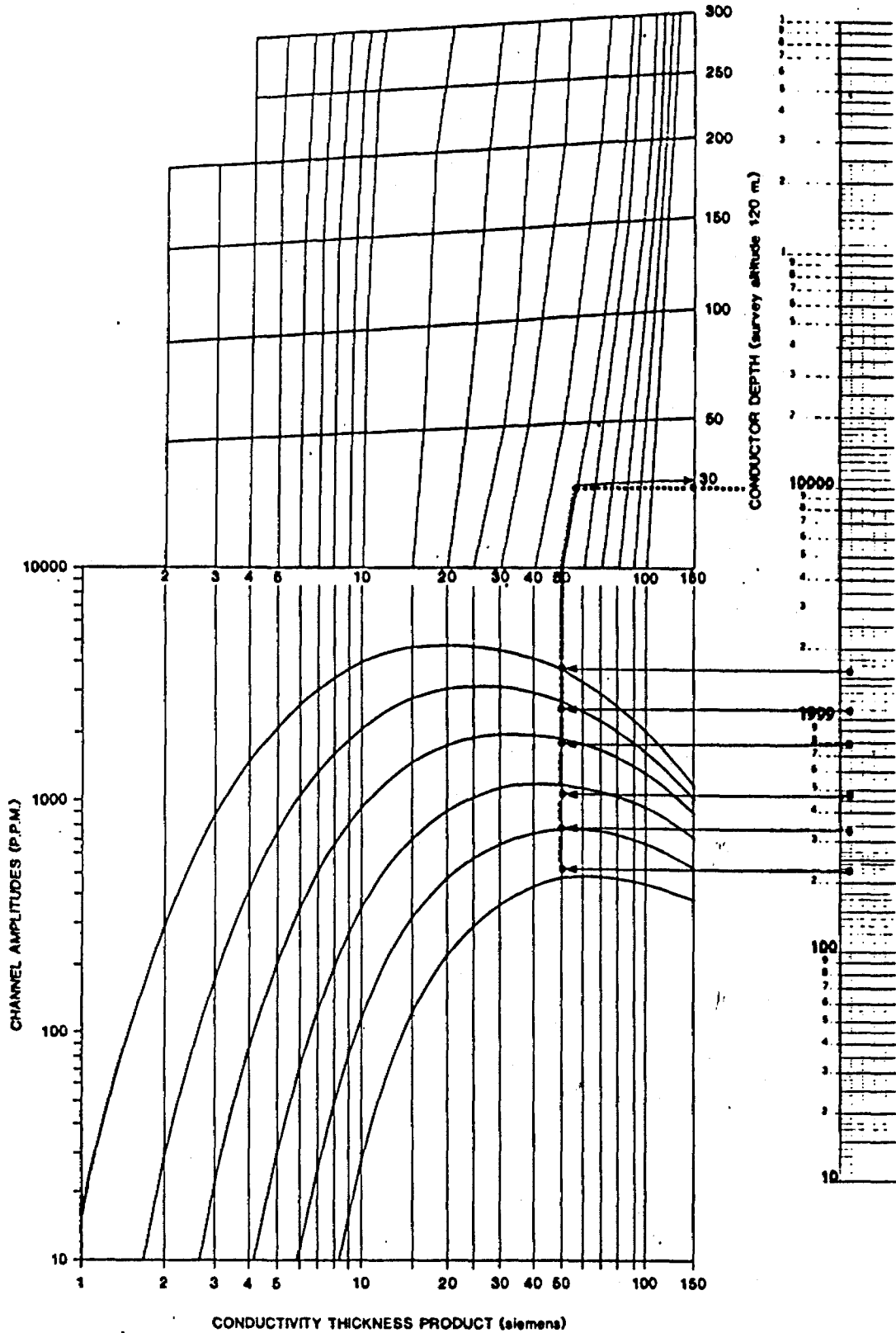

# QUESTOR INPUT THIN PLATE DIP ESTIMATION and AMPLITUDE NORMALIZATION GRAPH

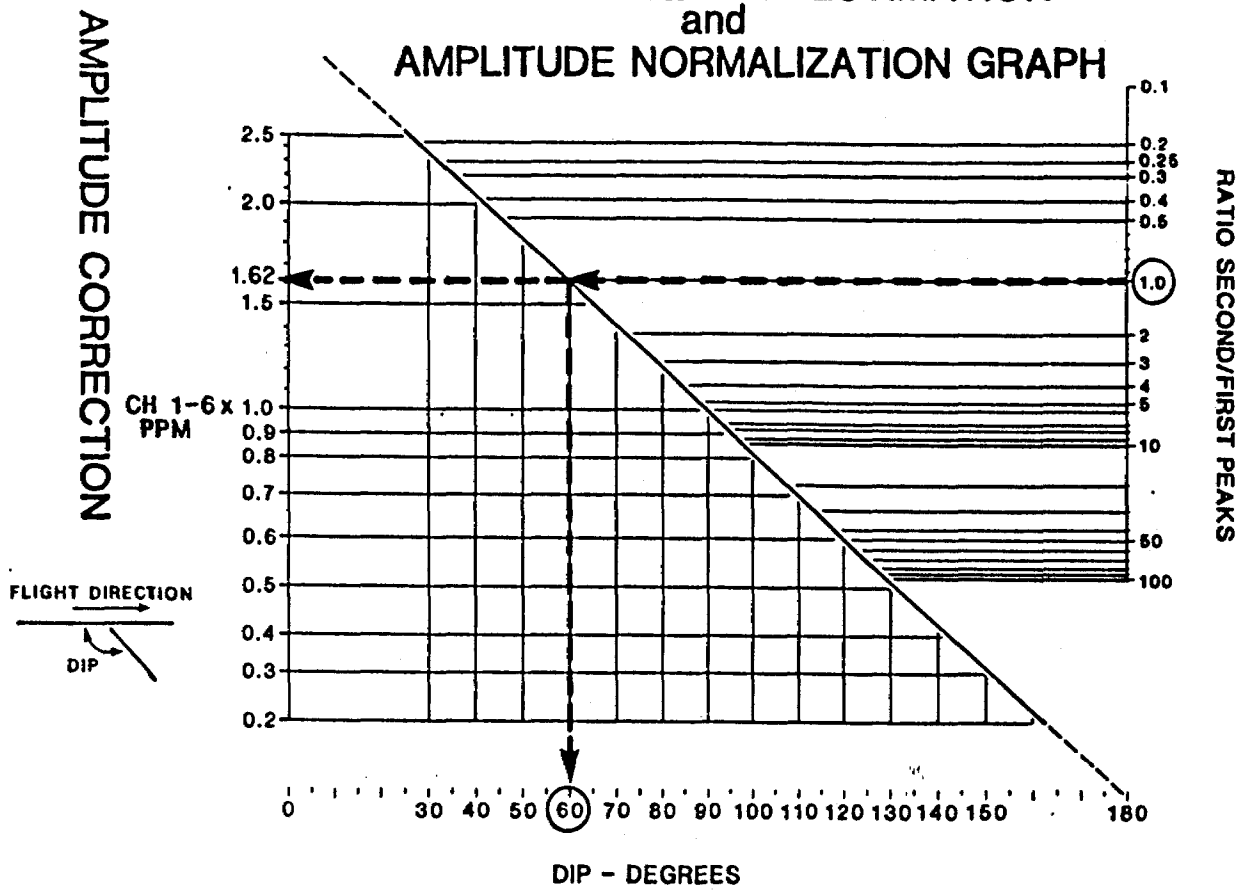

Figure I3

The asymmetric Tx-Rx configuration is very sensitive to changes of dip, particularly in the case of conductors dipping against the flight direction. In this circumstance, there is a change in the magnitude of the second/first peak ratio for all channels. The ratio of the amplitudes of the two peaks is a function of dip. The dip should be the first parameter determined in the quantitative interpretation of a dipping conductor. Before the amplitude is further used for an estimate of conductivity-thickness and depth, it must be normalized to a dip of  $90^{\circ}$ . This correction is performed by means of the Thin Plate Dip Estimation and Amplitude Normalization Graph, Figure G3.

From the graph, it can be seen that a vertical dyke conductor should have a second/first peak ratio of approximately 6, i.e., that the first peak will have 16% of the amplitude of the second peak. In the case of anomaly A, this condition is true. Conversely, should the dyke dip at  $60^{\circ}$ , the ratio will decrease to 1.0. Thus, the dip of a conductor can be estimated from the peak ratios of channel two by using the graph in Figure G3.

An example of amplitude correction determination is shown in Figure G3. A dipping conductor has an up-dip second-first peak ratio of 1.0 i.e., that the channel amplitudes of the minor first peak and major second peak of channel two are equal. Taking this ratio of 1.0 and applying the graph, a dip of  $60^{\circ}$  is obtained for the conductor showing an amplitude correction of approximately 1.62. Consequently, the correction factor is applied to the six channel amplitudes of the associative down-dip response.

To estimate the apparent strike length of a conductor, the ends of the conductive trend must be determined. Modelling has shown that the conductor ends are delineated by INPUT responses having channel amplitudes not less than 40% of those typical for the conductor. Responses with less than that of 40% are attributive to lateral coupling effects and are not considered as intercepts of the conductor. This is especially true for conductors of higher conductivity. Subsequently, the strike length of a conductor is equal to the distance between those responses representing the ends of the conductor.

# INPUT DIP ESTIMATION GRAPH

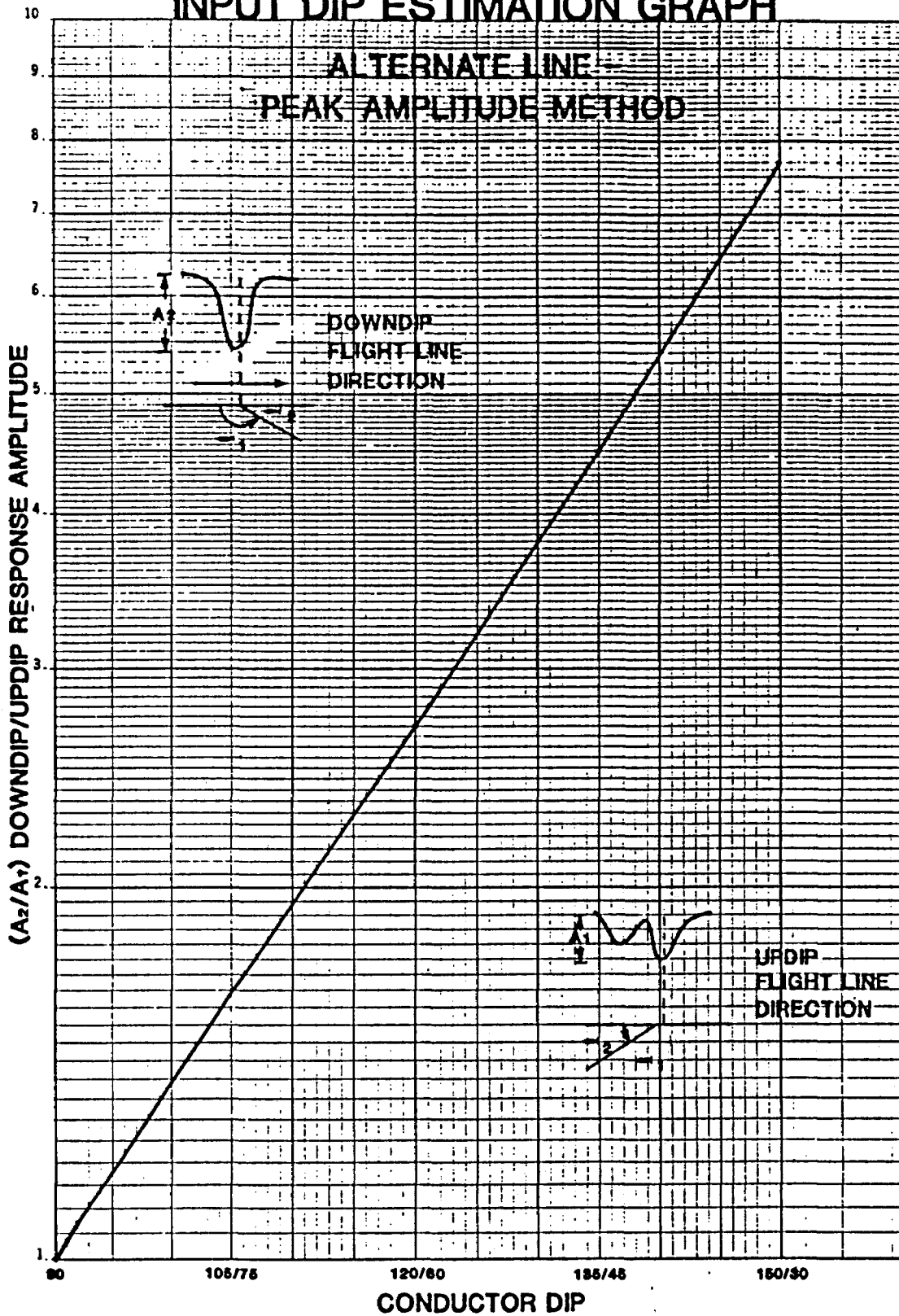

## APPENDIX H

### MAGNETOMETER: COMPENSATION, SURVEY AND PROCESSING

#### Aircraft Magnetic Compensation

In order for a high sensitivity magnetometer system to function without interference from the aircraft, it must be magnetically compensated. The sources of magnetic interference, produced by the aircraft are: a) eddy currents; b) aircraft electrical system; c) induced magnetism; and d) permanent magnetism. These sources of magnetic noise have distinguishable characteristics on the analogue records and a ground and airborne test will indicate the capabilities of the magnetometer installation. By following established procedures most of the noise sources are eliminated.

- a) Eddy currents are caused by movements of the larger conducting surfaces of the aircraft in the earth's magnetic field, whereby electric currents are generated, causing magnetic fields. By placing the sensor at the greatest practical distance from these surfaces and by not flying in turbulent wind conditions, eddy current noise can be minimized.
- b) Aircraft electrical systems with varying loads can lead to serious noise problems if consistent operations procedures and circuit layout are not properly designed. The switching of the aircraft's 28 volt DC to almost any component during

survey will create a variation in the static field existing under normal operating conditions. The three component compensator in the aircraft will see electrical system noise as DC level shifts from a heading invariant datum.

- c) Induced magnetic fields are produced by ferromagnetic parts (mainly engines) in the earth's magnetic field. For a major change in magnetic latitude, it is necessary to check for variation of the aircraft's induced magnetic field. This is also dependant on the aircraft's heading and altitude. Compensation is accomplished by critical positioning of permalloy strips near the sensor. These produce fields opposite to the induced magnetic field of the aircraft, effectively cancelling it.
  
- d) Permanent magnetism is produced by ferromagnetic parts within the aircraft. Compensation is accomplished with three orthogonal coils, through each of which an electrical current is passed, to create a resultant stable field opposite in polarity to the permanent field.

The compensation process has as its main objective the reduction of heading errors. These may be checked by flying the aircraft at survey altitude over a well defined non-anomalous landmark in the four cardinal headings. In addition, the effects of aircraft flight characteristics on the magnetometer installation are simulated by performing roll, pitch and yaw manouvers.

The aircraft has been originally compensated in Toronto, Ontario, where the induced field has been cancelled. In the survey area, a check is made to ensure that the permanent field does not induce heading dependant, magnetic field errors.

#### MAGNETOMETER SURVEY AND DATA ACQUISITION

The magnetometer survey is an integral part of INPUT operations, with no special procedures being required; with the exception of a ground magnetic recording station to monitor daily diurnal variations. The diurnal survey specifications relate to the control line spacing to minimize the possibilities of erroneous contours in area of low magnetic gradient.

The maximum diurnal gradient permitted is 20 gammas change within 5 minutes. The maximum control line spacing allowed is 8 kilometres. Where possible, control lines are routed through areas of low magnetic gradient over easily identified topographic points. As the time for the survey aircraft to span two control lines is approximately 2 minutes, a maximum diurnal anomaly of 4 nT (nanoTeslas) may exist after the data has been levelled.

The daily variation of the earth's magnetic field is monitored and recorded with a Geometrics G-826 Base Station Magnetometer and a GULTON or Hewlett Packard Strip Chart Recorder. The recorder has a 10 cm. chart width with a 100 nT full scale deflection, providing scaling of 1 nT/MM. An event marker provides time reference marks every minute. The chart speed is set to 20 cm/hour, with magnetometer readings taken every 4 or 10 seconds.



These readings may be digitally recorded using a portable data acquisition system synchronized with the aircraft data system, if required.

The magnetometer readings in the aircraft are recorded every second onto industry standard, 9-track tapes using the IBM NRZI Format.

APPENDIX I

Bibliography

- Barringer, A.R., 1962, The INPUT Airborne Electrical Pulse Prospecting System: Min. Cong. J., volume 48, page 49-52;
- Barringer Research Limited, 1962, Method and Apparatus for the Detection of Ore Bodies: United States Patent Office: 3.020,471;
- Barringer Research Limited, The Quantitative Interpretation of Airborne INPUT Electromagnetic Data: Barringer Research Technical Note;
- Becker, A., 1969, Simulation of Time-Domain, Airborne Electromagnetic System Response: Geophysics, volume 24, page 739-752;
- Becker, A., Gavreau, D., and Collett, L.S., 1972, Scale Model Study of Time-Domain Electromagnetic Response of Tabular Conductors: CIM Bull., volume 65, number 725, page 90-95;
- Dyck, A.V., Becker A., and Collett, L.S., 1974, Surficial Conductivity Mapping with the Airborne INPUT System: CIM Bull., volume 67, number 744, page 104-109;
- Ghosh, M.K., and West, G.F., 1971, EM Analogue Model Studies: Norman Paterson and Associates, Toronto; .

- Lazenby, P.G., 1972, Examples of Field Data Obtained with the  
INPUT Airborne Electromagnetic System: Questor  
Surveys Limited;
- Lazenby, P.G., 1972, New Developments in the INPUT Airborne EM  
System: CIM Bull., volume 66, number 732, page  
96-104;
- Lodha, G. S., West, G. F., 1976, Practical Airborne EM (AEM)  
Interpretation Using a Sphere Model: Geophysics,  
volume 41, page 1157-1169;
- Mallick, K., 1972, Conducting Sphere in Electromagnetic INPUT  
Field: Geophysical Prospecting, volume 20, page  
293-303;
- Macnae, James C., 1979, Kimberlites and Exploration Geophysics:  
Geophysics, volume 44, number 8, page 1395-1416;
- Mishra, D.C., Murthy, K.S.R., and Narain, H., 1978, Interpretation  
of Time-Domain Airborne Electromagnetic (INPUT)  
Anomalies: Geoexplor., volume 16, page 203-222;
- Morrison, H.F., Phillips, R.J., and O'Brien, D.P. 1969,  
Quantitative Interpretation of Transient  
Electromagnetic Fields Over a Layered Half-Space:  
Geophys. Prosp. volume 7, page 82-101;
- Nelson, P.H., and Morris, D.B., 1969, Theoretical Response of a  
Time-Domain Airborne Electromagnetic System:  
Geophysics, volume 34, page 729-738;
- Nelson, P.H., 1973, Model Results and Field Checks for a  
Time-Domain Airborne EM System: Geophysics,  
volume 38, page 845-853;

Questor Surveys Limited, 1974, Airborne INPUT Responses: Questor Surveys Limited, Mississauga, Ontario.

Ramani, N., 1981, Barringer/Questor Mark VI INPUT Anomalies Over Thin Sheet Conductors: To accompany the Electromagnetic Maps for the Atikokan-Mine Centre Area, Geophysical/Geochemical Section, Ontario Geological Survey.

Verma, S.K., 1975, Resolution of Responses due to Conductive Overburden and Ore-Body through Time-Domain EM Measurements: Geophysical Prospecting, volume 23, page 292-299.

West, G. F., MacNae, J., 1982, Grant 124, Model Studies of Electromagnetic Prospecting: Geoscience Research Grant Program, Summary of Research 1981-1982, Ontario Geological Survey Miscellaneous Paper 103, page 210-212;

# 556/86

Mini



32E055E0012 2.9789 HURTUBISE

900

Type of Survey: **AIRBORNE ELECTROMAGNETIC AND MAGNETIC**

Claim Holder: **GLEN AUDGN RESOURCES LIMITED**

Inspector's Licence No.: **T-1915**

Address: **Box 1637 TIMMINS ONTARIO**

Survey Company: **QUESTER SURVEY LIMITED**

Total Miles of line: **125 m**

Name and Address of Author (Technical report): **MARCEL KONIG 6380 VISCOUNT ROAD MISSISSAUGA, ONTARIO**

Credits Requested per Each Column in Columns at right

Mining Claims Traversed (List in numerical sequence)

Special Provisions	Geophysical	Days per Claim
For first survey: Enter 40 days. (This includes line cutting)	- Electromagnetic	
	- Magnetometer	
For each additional survey: using the same grid: Enter 20 days (for each)	- Radiometric	
	- Other	
	Geological	
	Geochemical	

Man Days	Geophysical	Days per Claim
Complete reverse side and enter total(s) here  <b>DEC 18 1986</b> <b>10240m</b> <i>[Signature]</i>	- Electromagnetic	
	- Magnetometer	
	- Radiometric	
	- Other	
	Geological	
	Geochemical	

Airborne Credits	Days per Claim
Note: Special provisions credits do not apply to Airborne Surveys. <b>125m lines</b>	Electromagnetic: <b>30</b>
	Magnetometer: <b>30</b>
	Radiometric: <b></b>

Expenditures (excludes power stripping)

Type of Work Performed

Performed on Claim(s)

Calculation of Expenditure Days Credits

Total Expenditures ÷ 15 = Total Days Credits

\$  ÷ 15 =

Instructions: Total Days Credits may be apportioned at the claim holder's choice. Enter number of days credits per claim selected in columns at right.

Date: **Dec 16 1986**  
Recorded Holder or Agent (Signature): **Marcel Konig**

Mining Claim		Expend. Days Cr.	Mining Claim		Expend. Days Cr.
Prefix	Number		Prefix	Number	
See attached claim list				877752	
	877731-			877753	
	877732			877754	
	877733			877755	
	877734			877756	
	877735			877757	
	877736			877758	
	877737			877759	
	877738			877760	
	877739			877761	
	877740			877762	
	877741			877763	
	877742			877764	
	877743			877765	
	877744			878006	
	877745			878007	
	877746			878008	
	877747			878009	
	877748			878010	
	877749			878011	
	877750			878012	
	877751			878013	
				878014	

Total number of mining claims covered by this report of work: **92**

**For Office Use Only**

Total Days Cr. Recorded: **5520**    Date Recorded: **DEC 18 1986**    Mining Reporter: **ACTING**

Date Approved as Recorded: **87.3.9**    [Signature]

Certification Verifying Report of Work

I hereby certify that I have a personal and intimate knowledge of the facts set forth in the Report of Work annexed hereto, having performed the work or witnessed same during and/or after its completion and the annexed report is true.

Name and Postal Address of Person Certifying: **MARCEL KONIG 6380 VISCOUNT ROAD MISSISSAUGA, ONTARIO**

Date Certified: **Dec 16 1986**    Certified by (Signature): **Marcel Konig**

CONTINUED

29789

878015  
878016  
878017  
878018  
878019  
878020  
878021  
878022  
878023

877632  
877633  
877634  
877635  
877636  
877637  
877638  
877639  
877640  
877641  
877642  
877643  
877644  
877645  
877646  
877647  
877648  
877649  
877650

877686  
877687  
877688  
877689  
877690  
877691  
877692  
877693  
877694  
877695  
877696  
877697  
877698  
877699

878083  
878084  
878085  
877766  
877767  
877768



Ontario

Ministry of  
Northern Development  
and Mines

**Geophysical-Geological-Geochemical  
Technical Data Statement**

File \_\_\_\_\_

TO BE ATTACHED AS AN APPENDIX TO TECHNICAL REPORT  
FACTS SHOWN HERE NEED NOT BE REPEATED IN REPORT  
TECHNICAL REPORT MUST CONTAIN INTERPRETATION, CONCLUSIONS ETC.

Type of Survey(s) AIRBORNE INPUT AND MAGNETIC SURVEY

Township or Area MURTUBISE / ST. LAURENT

Claim Holder(s) GLEN AUDEN RESOURCES LIMITED

Survey Company QUESTOR AIRBORNE INPUT AND MAGNETIC

Author of Report MARCEL KONING / NADIA CHABA

Address of Author 6380 VISCOUNT RD MISSISSAUGA / BOX 1725 TIMMINS

Covering Dates of Survey NOV 23/86 - DEC 9/86  
(linecutting to office)

Total Miles of Line Cut \_\_\_\_\_

<u>SPECIAL PROVISIONS CREDITS REQUESTED</u>	<u>DAYS per claim</u>
ENTER 40 days (includes line cutting) for first survey.	Geophysical --Electromagnetic _____ --Magnetometer _____ --Radiometric _____ --Other _____
ENTER 20 days for each additional survey using same grid.	Geological _____ Geochemical _____

AIRBORNE CREDITS (Special provision credits do not apply to airborne surveys)

Magnetometer 30 Electromagnetic 30 Radiometric \_\_\_\_\_  
(enter days per claim)

DATE: FEB 13/87 SIGNATURE: Madhava Chaba  
Author of Report or Agent

Res. Geol. \_\_\_\_\_ Qualifications 26239

Previous Surveys

File No.	Type	Date	Claim Holder

<b>MINING CLAIMS TRAVERSED</b>	
List numerically	
L877731	L877752
(prefix)	(number)
877732	L877753
877733	877754
877734	877755
877735	877756
877736	877757
877737	877758
877738	877759
877739	877760
877740	877761
877741	877762
877742	877763
877743	877764
877743	877765
877744	878006
877745	878007
877746	878008
877747	878009
877748	878010
877749	878011
877750	878012
877751	878013
877751	878014
<b>TOTAL CLAIMS</b>	<u>92</u>

If space insufficient, attach list

OFFICE USE ONLY

# GEOPHYSICAL TECHNICAL DATA

GROUND SURVEYS – If more than one survey, specify data for each type of survey

Number of Stations \_\_\_\_\_ Number of Readings \_\_\_\_\_  
Station interval \_\_\_\_\_ Line spacing \_\_\_\_\_  
Profile scale \_\_\_\_\_  
Contour interval \_\_\_\_\_

## MAGNETIC

Instrument \_\_\_\_\_  
Accuracy – Scale constant \_\_\_\_\_  
Diurnal correction method \_\_\_\_\_  
Base Station check-in interval (hours) \_\_\_\_\_  
Base Station location and value \_\_\_\_\_  
\_\_\_\_\_

## ELECTROMAGNETIC

Instrument \_\_\_\_\_  
Coil configuration \_\_\_\_\_  
Coil separation \_\_\_\_\_  
Accuracy \_\_\_\_\_  
Method:  Fixed transmitter  Shoot back  In line  Parallel line  
Frequency \_\_\_\_\_  
(specify V.L.F. station)  
Parameters measured \_\_\_\_\_

## GRAVITY

Instrument \_\_\_\_\_  
Scale constant \_\_\_\_\_  
Corrections made \_\_\_\_\_  
\_\_\_\_\_  
Base station value and location \_\_\_\_\_  
\_\_\_\_\_  
Elevation accuracy \_\_\_\_\_

## INDUCED POLARIZATION RESISTIVITY

Instrument \_\_\_\_\_  
Method  Time Domain  Frequency Domain  
Parameters – On time \_\_\_\_\_ Frequency \_\_\_\_\_  
– Off time \_\_\_\_\_ Range \_\_\_\_\_  
– Delay time \_\_\_\_\_  
– Integration time \_\_\_\_\_  
Power \_\_\_\_\_  
Electrode array \_\_\_\_\_  
Electrode spacing \_\_\_\_\_  
Type of electrode \_\_\_\_\_



CONSCOTT - GLEN AUDEN RESOURCES      92 CLAIMS

CONTINUED

878015	877632	877686	878083
878016	877633	877687	878084
878017	877634	877688	878085
878018	877635	877689	
878019	877636	877690	877766
878020	877637	877691	877767
878021	877638	877692	877768
878022	877639	877693	<i>These have already been transferred</i>
878023	877640	877694	
	877641	877695	
	877642	877696	
	877643	877697	
	877644	877698	
	877645	877699	
	877646		
	877647		
	877648		
	877649		
	877650		

SELF POTENTIAL

Instrument \_\_\_\_\_ Range \_\_\_\_\_

Survey Method \_\_\_\_\_

Corrections made \_\_\_\_\_

RADIOMETRIC

Instrument \_\_\_\_\_

Values measured \_\_\_\_\_

Energy windows (levels) \_\_\_\_\_

Height of instrument \_\_\_\_\_ Background Count \_\_\_\_\_

Size of detector \_\_\_\_\_

Overburden \_\_\_\_\_

(type, depth - include outcrop map)

OTHERS (SEISMIC, DRILL WELL LOGGING ETC.)

Type of survey \_\_\_\_\_

Instrument \_\_\_\_\_

Accuracy \_\_\_\_\_

Parameters measured \_\_\_\_\_

Additional information (for understanding results) \_\_\_\_\_

AIRBORNE SURVEYS

Type of survey(s) QUESTOR AIRBORNE INPUT GM AND MAGNETIC SURVEY

Instrument(s) QUESTOR (BARLINGER MILV) 2ms, INPUT system, Geometric G-813 Proton  
(specify for each type of survey) Mag

Accuracy 1mT, six channels  
(specify for each type of survey)

Aircraft used A short sleyven C-60RG

Sensor altitude 30m

Navigation and flight path recovery method \_\_\_\_\_

Aircraft altitude 122 meters Line Spacing 125m

Miles flown over total area 214.28 line km Over claims only ALL  
133.93 line km

GEOCHEMICAL SURVEY – PROCEDURE RECORD

Numbers of claims from which samples taken \_\_\_\_\_  
\_\_\_\_\_  
\_\_\_\_\_

Total Number of Samples \_\_\_\_\_

Type of Sample \_\_\_\_\_  
(Nature of Material)

Average Sample Weight \_\_\_\_\_

Method of Collection \_\_\_\_\_  
\_\_\_\_\_

Soil Horizon Sampled \_\_\_\_\_

Horizon Development \_\_\_\_\_

Sample Depth \_\_\_\_\_

Terrain \_\_\_\_\_  
\_\_\_\_\_

Drainage Development \_\_\_\_\_

Estimated Range of Overburden Thickness \_\_\_\_\_  
\_\_\_\_\_  
\_\_\_\_\_

SAMPLE PREPARATION

(Includes drying, screening, crushing, ashing)

Mesh size of fraction used for analysis \_\_\_\_\_  
\_\_\_\_\_  
\_\_\_\_\_  
\_\_\_\_\_

General \_\_\_\_\_  
\_\_\_\_\_  
\_\_\_\_\_  
\_\_\_\_\_  
\_\_\_\_\_  
\_\_\_\_\_  
\_\_\_\_\_  
\_\_\_\_\_  
\_\_\_\_\_  
\_\_\_\_\_  
\_\_\_\_\_

ANALYTICAL METHODS

Values expressed in:      per cent        
   p. p. m.        
   p. p. b.     

Cu, Pb, Zn, Ni, Co, Ag, Mo, As, -(circle)

Others \_\_\_\_\_

Field Analysis (\_\_\_\_\_ tests)

Extraction Method \_\_\_\_\_

Analytical Method \_\_\_\_\_

Reagents Used \_\_\_\_\_

Field Laboratory Analysis

No. (\_\_\_\_\_ tests)

Extraction Method \_\_\_\_\_

Analytical Method \_\_\_\_\_

Reagents Used \_\_\_\_\_

Commercial Laboratory (\_\_\_\_\_ tests)

Name of Laboratory \_\_\_\_\_

Extraction Method \_\_\_\_\_

Analytical Method \_\_\_\_\_

Reagents Used \_\_\_\_\_

General \_\_\_\_\_  
\_\_\_\_\_  
\_\_\_\_\_  
\_\_\_\_\_  
\_\_\_\_\_  
\_\_\_\_\_  
\_\_\_\_\_  
\_\_\_\_\_  
\_\_\_\_\_  
\_\_\_\_\_

AREAS WITHDRAWN FROM DISPOSITION

M.R.O. - MINING RIGHTS ONLY  
 S.R.O. - SURFACE RIGHTS ONLY  
 M+S. - MINING AND SURFACE RIGHTS  
 Description Order No. Date Disposition File

NOSEWORTHY TOWNSHIP

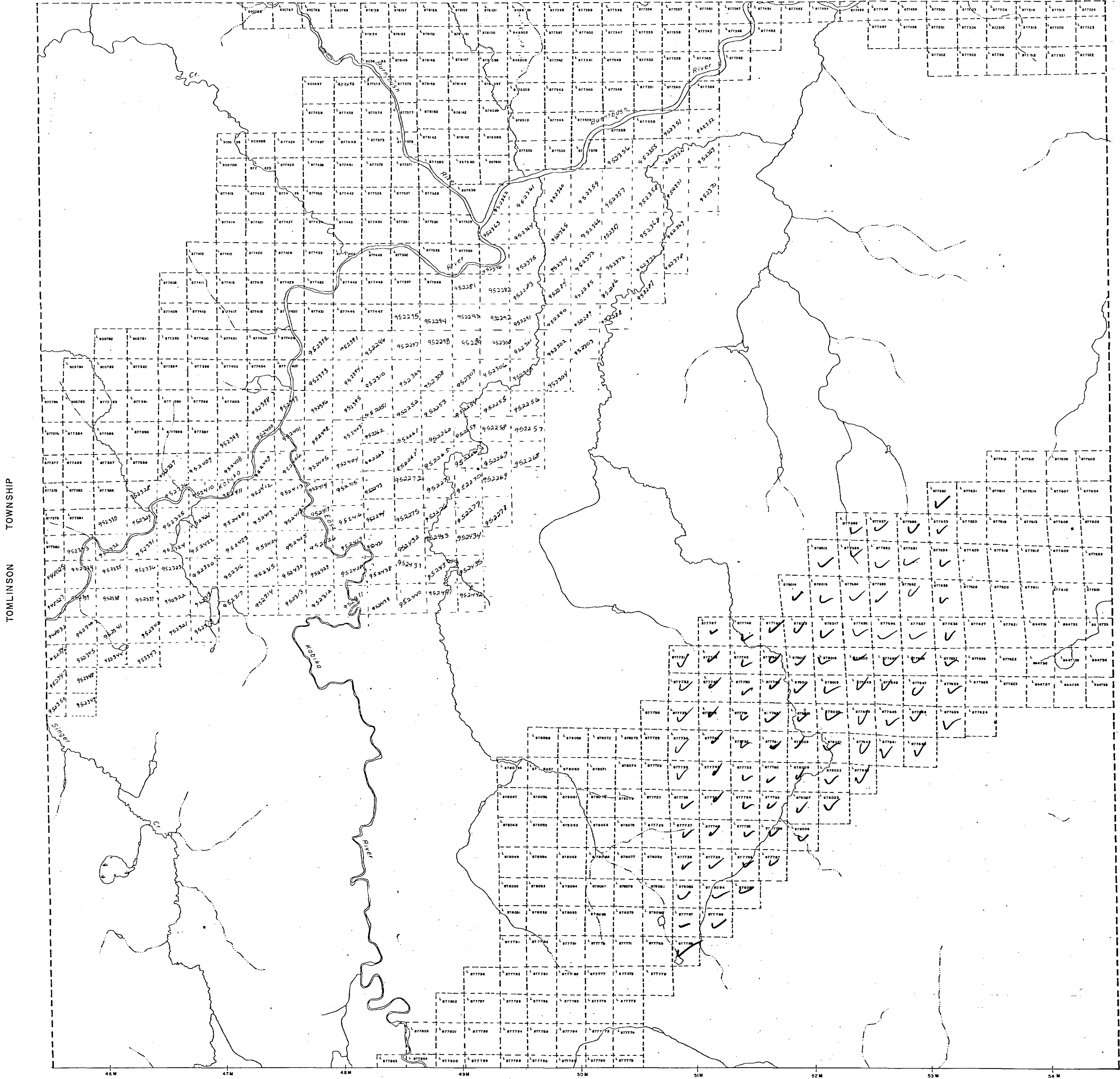

**LEGEND**

HIGHWAY AND ROUTE No.	
OTHER ROADS	
TRAILS	
SURVEYED LINES	
TOWNSHIP, BASE LINES, ETC.	
LOTS, MINING CLAIMS, PARCELS, ETC.	
UNSURVEYED LINES	
LOT LINES	
PARCEL BOUNDARY	
MINING CLAIMS ETC.	
RAILWAY AND RIGHT OF WAY	
UTILITY LINES	
NON-PERMANENT STREAM	
FLOODING OR FLOODING RIGHTS	
SUBDIVISION OR COMPOSITE PLAN	
RESERVATIONS	
ORIGINAL SHORELINE	
MARSH OR MUSKEG	
MINES	
TRAVERSE MONUMENT	

**DISPOSITION OF CROWN LANDS**

TYPE OF DOCUMENT	SYMBOL
PATENT SURFACE & MINING RIGHTS	
SURFACE RIGHTS ONLY	
MINING RIGHTS ONLY	
LEASE, SURFACE & MINING RIGHTS	
SURFACE RIGHTS ONLY	
MINING RIGHTS ONLY	
LICENCE OF OCCUPATION	
ORDER IN COUNCIL	
RESERVATION	
CANCELLED	
SAND & GRAVEL	

SCALE 1:20 000

DATE OF ISSUE  
 FEB 10 1987  
 LARDER LAKE  
 MINING RECORDER'S OFFICE

TOWNSHIP  
**HURTUBISE**  
 M.N.R. ADMINISTRATIVE DISTRICT  
 COCHRANE  
 MINING DIVISION  
 LARDER LAKE  
 LAND TITLES / REGISTRY DIVISION  
 COCHRANE

Ministry of Natural Resources and Mines  
 Ministry of Northern Development and Mines

01<sup>st</sup> OCTOBER 1986  
 G-3518



32E858E0012 2.9789 HURTUBISE

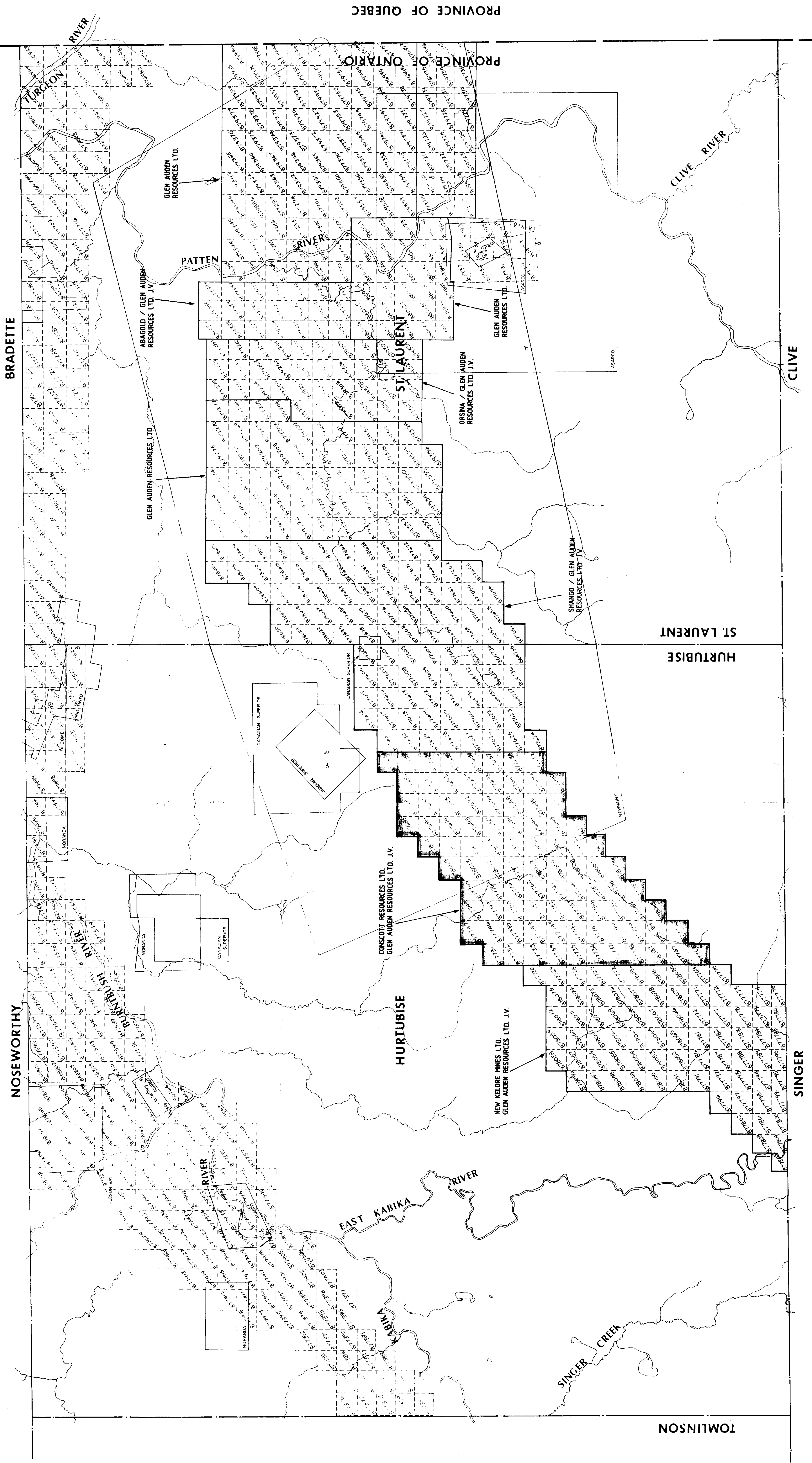

29789

REVISIONS	ROBERT S. MIDDLETON EXPLORATION SERVICES INC.
	for CONSCOFF RESOURCES LTD. GLEN AUDEN RESOURCES LTD. J.V.
	Title CLAIM MAP & PREVIOUS WORK Hurtubise & St. Laurent Townships, Ontario
	Date: Jan 1986 Scale: 1:31680 N.T.S.
	Drawn: P.G. Approved: R.P.B. File:

MAGNETIC CONTOURS

- 5 GAMMA CONTOUR LINE
- 25 GAMMA CONTOUR LINE
- 100 GAMMA CONTOUR LINE
- 500 GAMMA CONTOUR LINE



NEW KELORE MINES LTD.  
GLEN AUDEN RESOURCES LTD. J.V.

CONSCOTT RESOURCES LTD.  
GLEN AUDEN RESOURCES LTD. J.V.

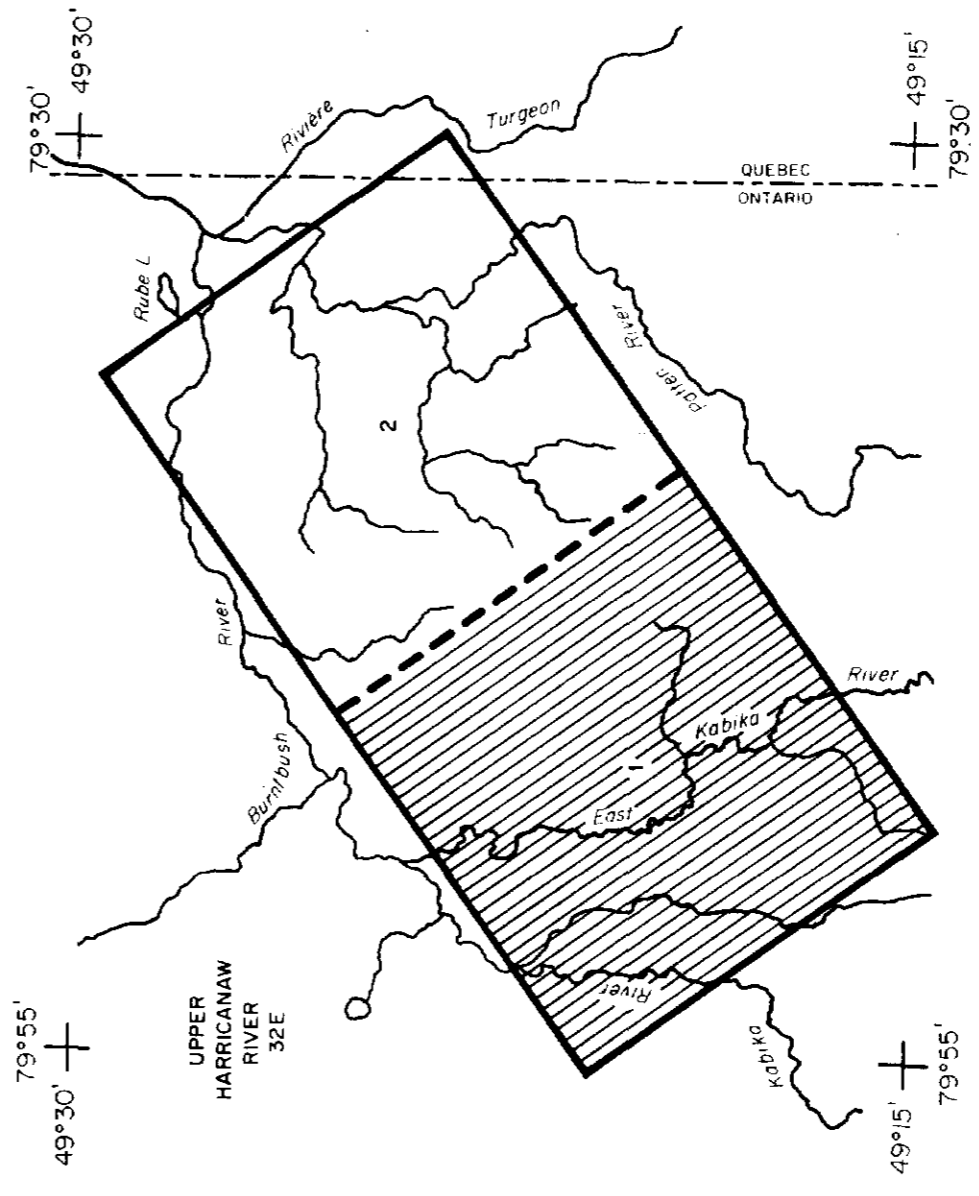

TOTAL MAGNETIC INTENSITY SURVEY

GLEN AUDEN RESOURCES LIMITED

HURTUBISE TOWNSHIP

PROVINCES OF ONTARIO AND QUEBEC

SCALE 1:20000

FILE NO. 28041

SHEET NO. 1 OF 2

DATE NOVEMBER 1986

QUESTOR SURVEYS LIMITED  
MISSISSAUGA, ONTARIO, CANADA

C151



MAGNETIC CONTOURS

- 5 GAMMA CONTOUR LINE
- 25 GAMMA CONTOUR LINE
- 100 GAMMA CONTOUR LINE
- 500 GAMMA CONTOUR LINE

GLEN AUDEN RESOURCES LTD.  
(58)

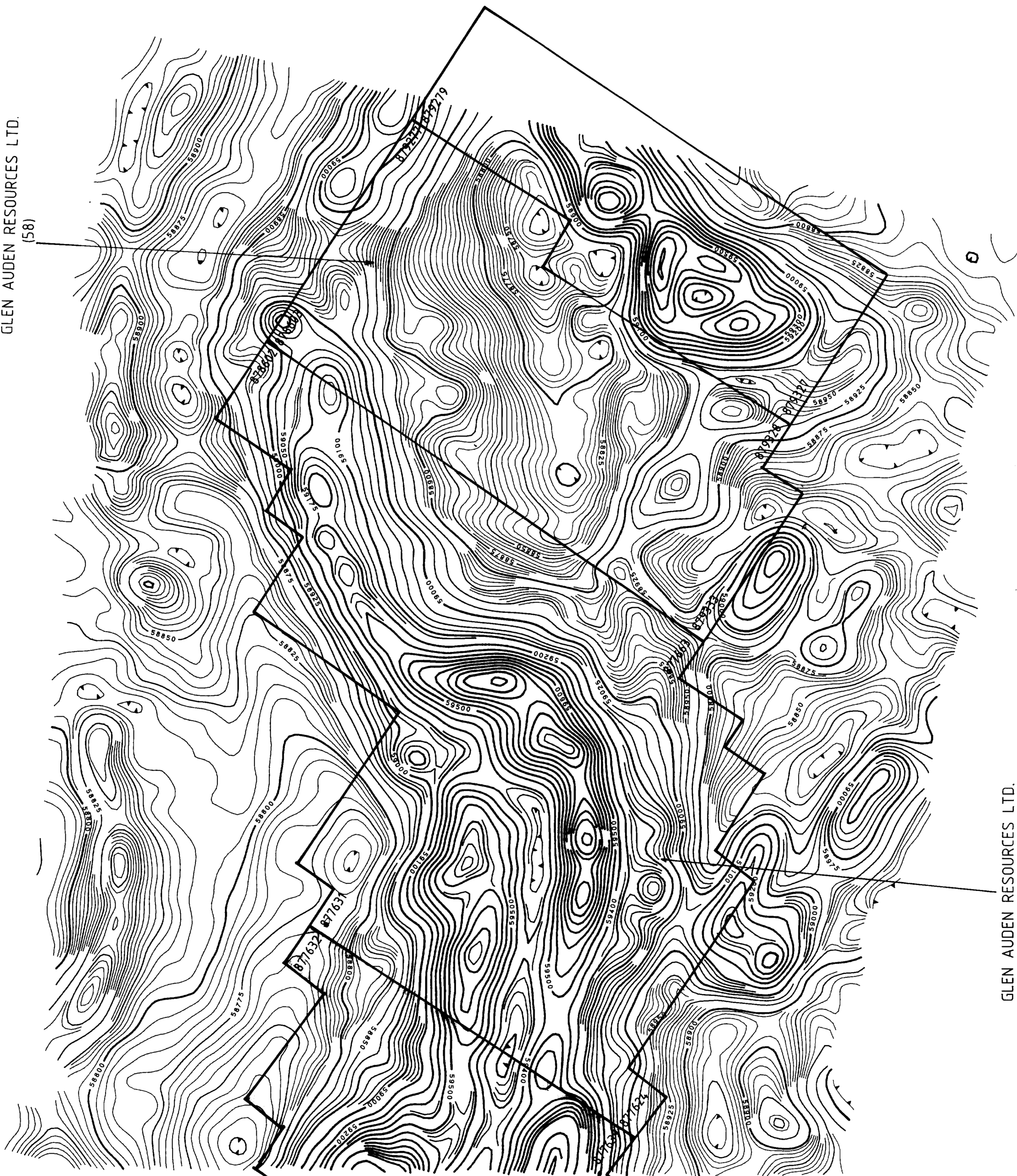

GLEN AUDEN RESOURCES LTD.

CONSCOTT RESOURCES LTD.  
GLEN AUDEN RESOURCES LTD. J.V.

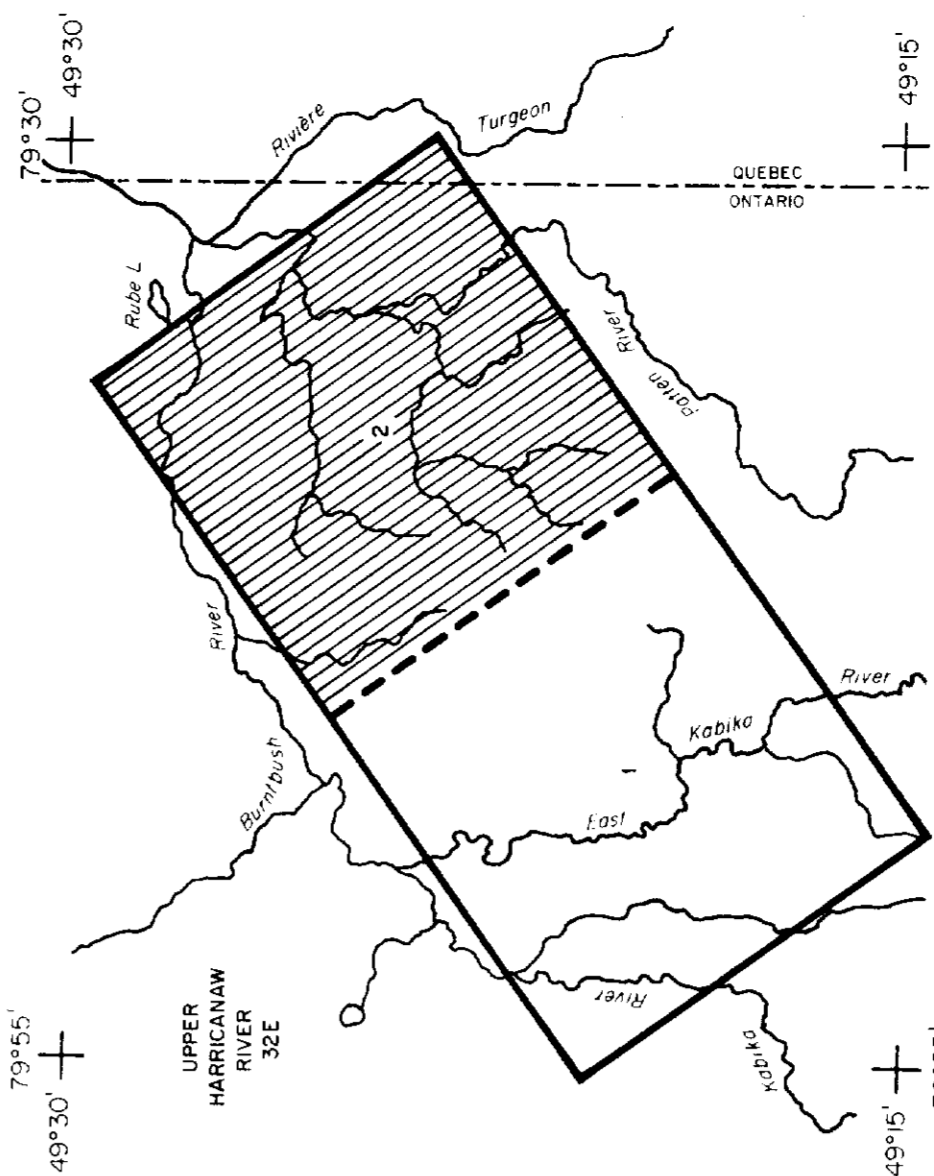

TOTAL MAGNETIC INTENSITY SURVEY

GLEN AUDEN RESOURCES LIMITED

HURTUBISE TOWNSHIP

PROVINCES OF ONTARIO AND QUEBEC

SCALE 1:20000

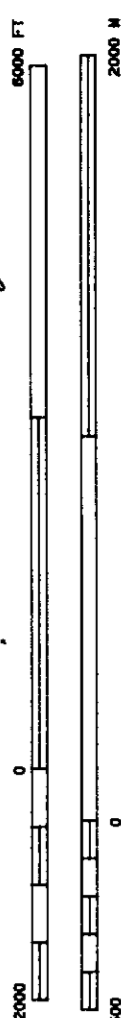

FILE NO. 28041

SHEET NO. 2 OF 2

DATE NOVEMBER 1986

QUESTOR SURVEYS LIMITED  
MISSISSAUGA ONTARIO CANADA

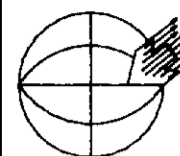

FILE NO.



CONTOUR LEGEND

- 0.05 GAMMAS/METER
- 0.25 GAMMAS/METER
- 1.00 GAMMAS/METER
- 5.00 GAMMAS/METER

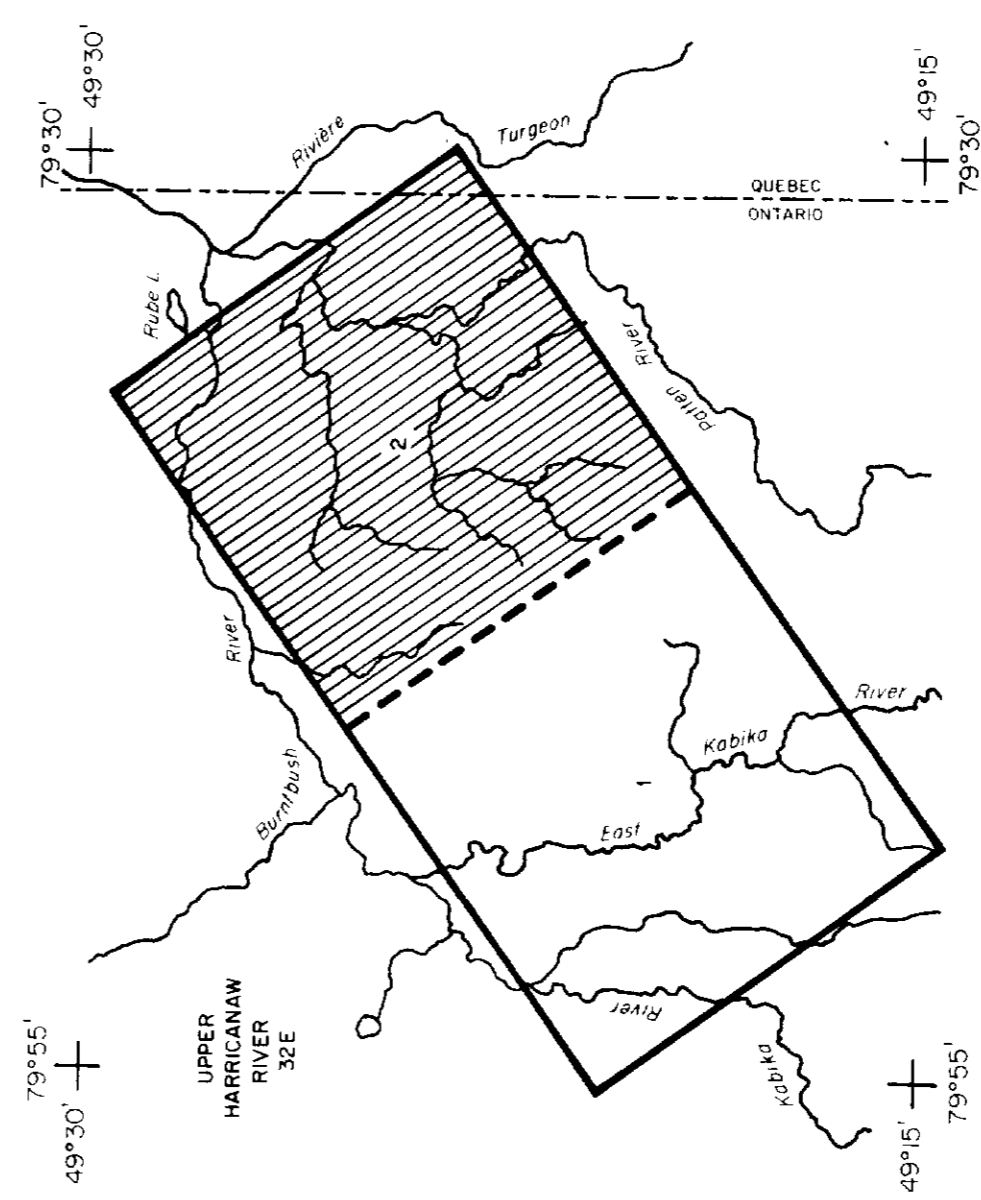

CALCULATED VERTICAL MAGNETIC GRADIENT

GLEN AUDEN RESOURCES LIMITED  
**HURTHOUSE TOWNSHIP**  
PROVINCES OF ONTARIO AND QUEBEC

SCALE 1:20000  
1000 FT  
2000 FT  
3000 FT

FILE NO. 28041  
SHEET NO. 2 OF 2  
DATE NOVEMBER 1986

QUESTOR SURVEYS LIMITED  
MISSISSAUGA, ONTARIO, CANADA

C. 15.2

GLEN AUDEN RESOURCES LTD.  
(58)



GLEN AUDEN RESOURCES LTD.

CONSCOTT RESOURCES LTD.  
GLEN AUDEN RESOURCES LTD. J.V.





CONTOUR LEGEND

0.05 GAMMAS/METER  
 0.25 GAMMAS/METER  
 1.00 GAMMAS/METER  
 5.00 GAMMAS/METER

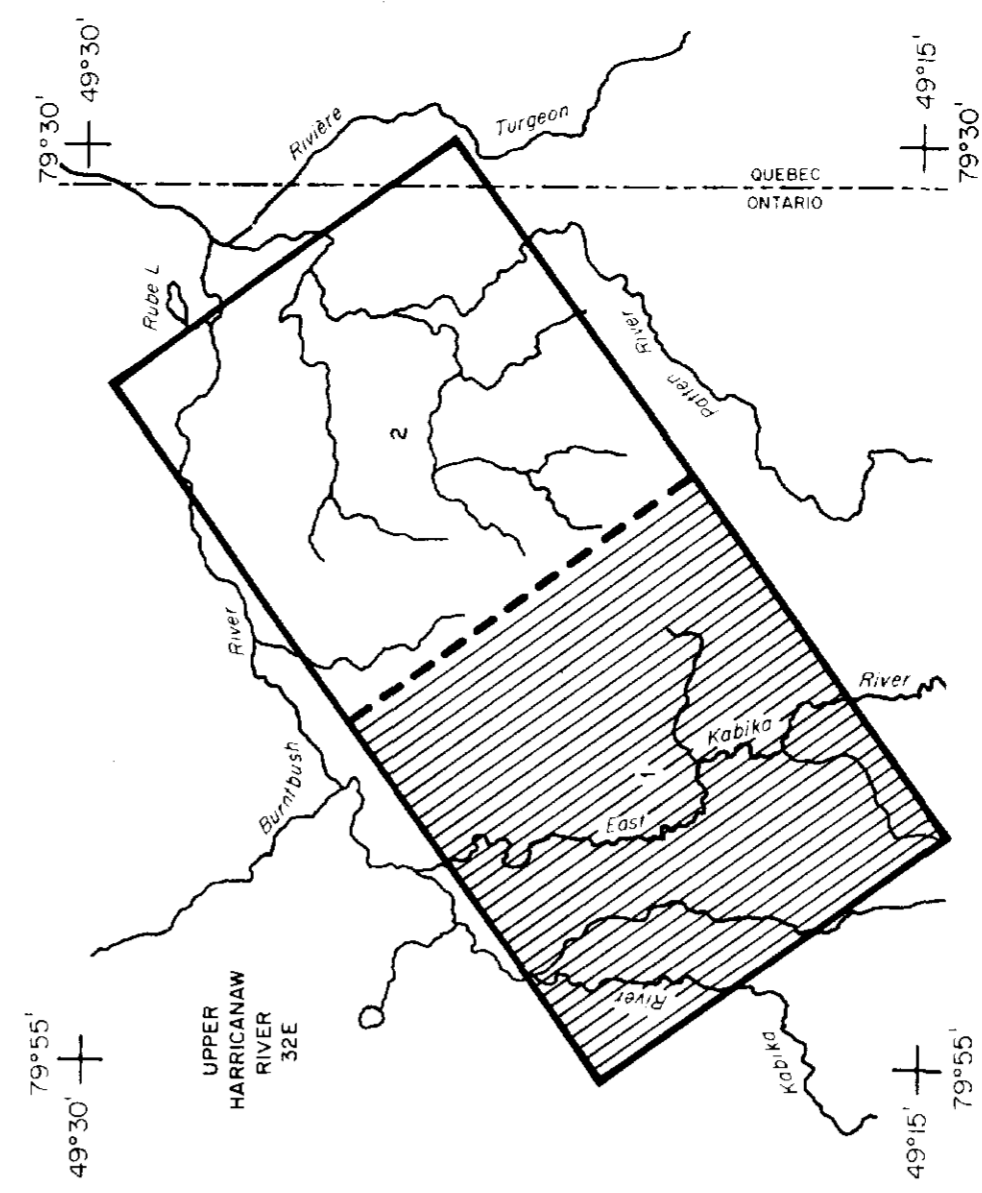

CALCULATED VERTICAL MAGNETIC GRADIENT

GLEN AUDEN RESOURCES LIMITED  
**HURTHOUSE TOWNSHIP**  
 PROVINCES OF ONTARIO AND QUEBEC

29787  
 SCALE 1:20000

FILE NO. 28041  
 SHEET NO. 1 OF 2  
 DATE NOVEMBER 1986

QUESTOR SURVEYS LIMITED  
 MISSISSAUGA ONTARIO CANADA

C166

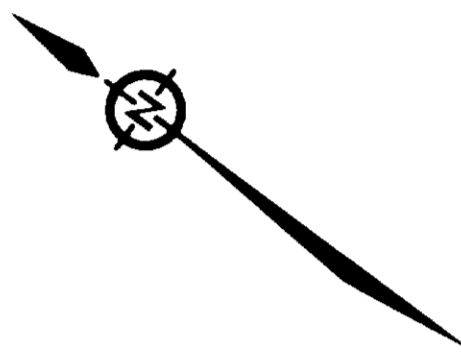

CONSCOTT RESOURCES LTD.  
 GLEN AUDEN RESOURCES LTD. J.V.

NEW KELORE MINES LTD.  
 GLEN AUDEN RESOURCES LTD. J.V.

**INPUT PEAK RESPONSE SYMBOLS 2ms PULSE**

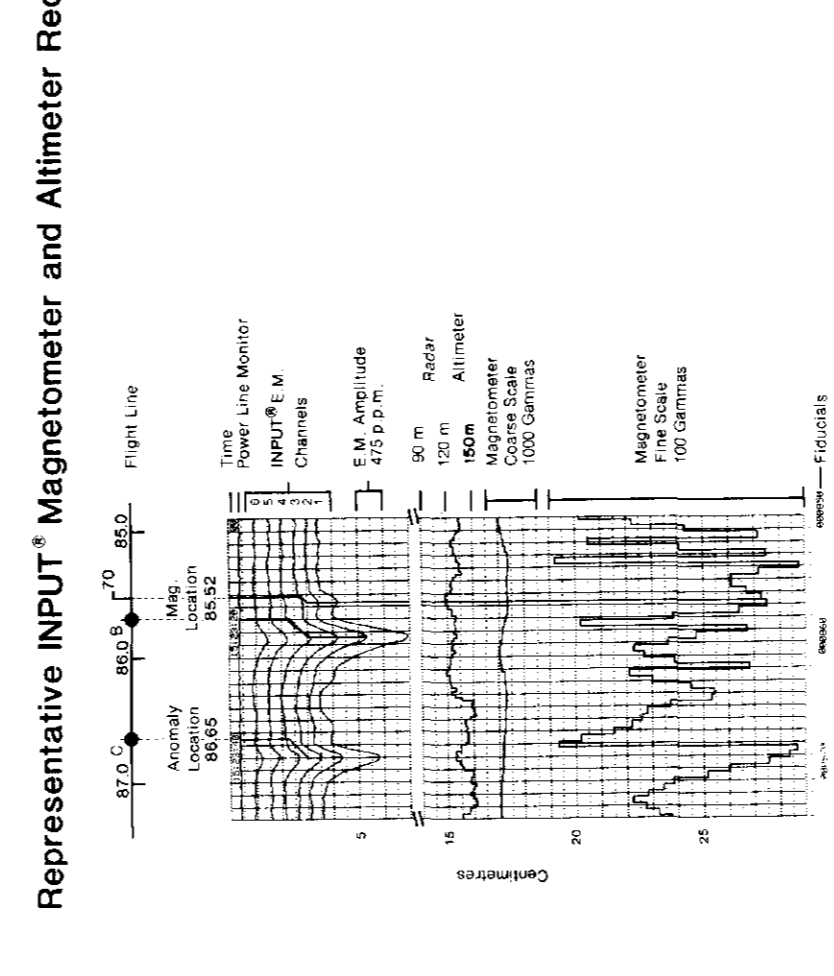
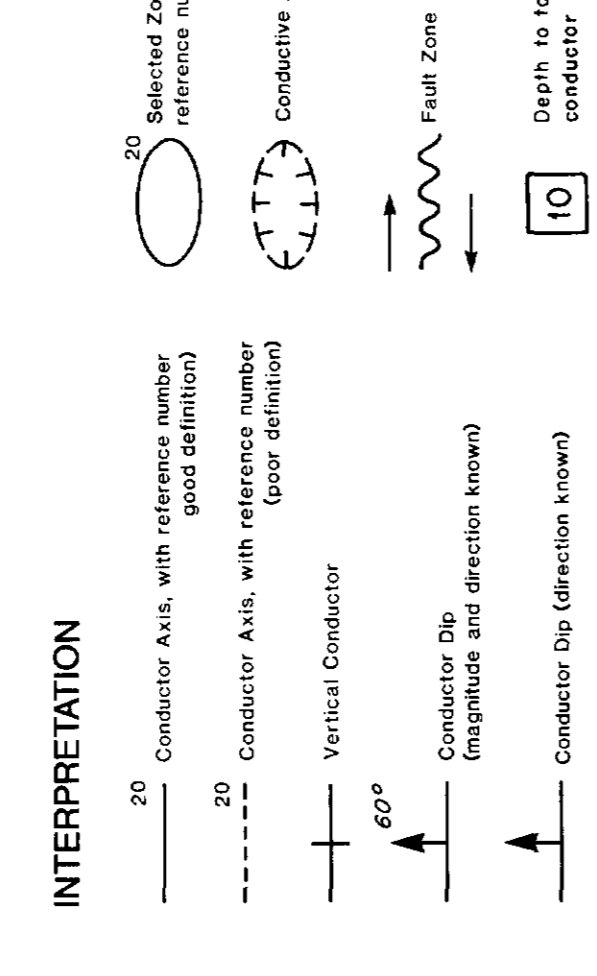
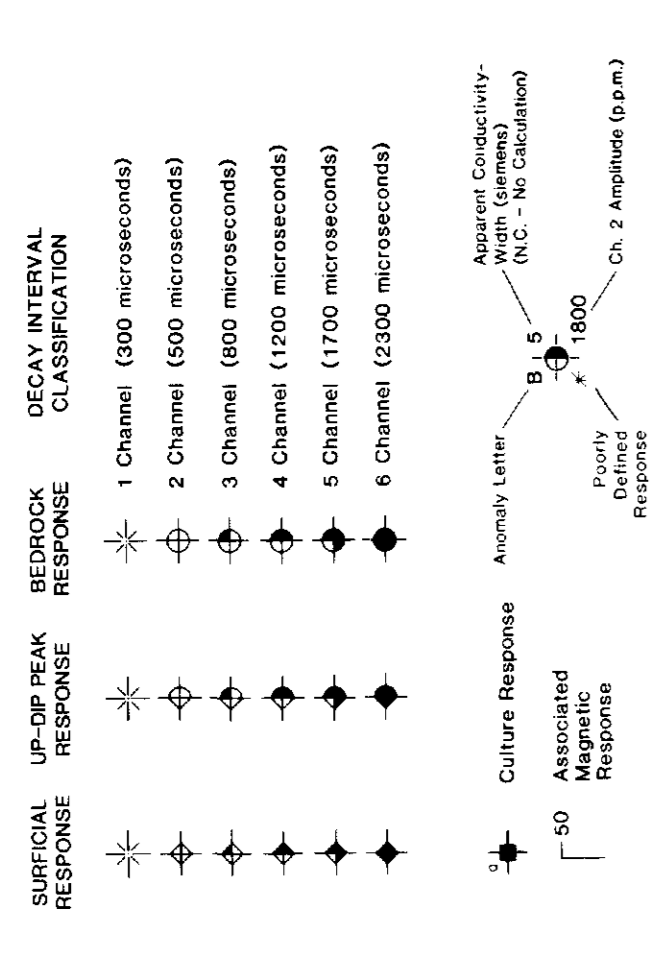

**DESCRIPTIVE NOTES**

This project is included with the Barringer-Quinnair Map VI (NHT) Series E.M. and is subject to the same terms and conditions of sale. The NHT Series E.M. is a 1:250,000 scale map of the Province of Ontario, Canada, and is published by the Geological Survey of Canada.

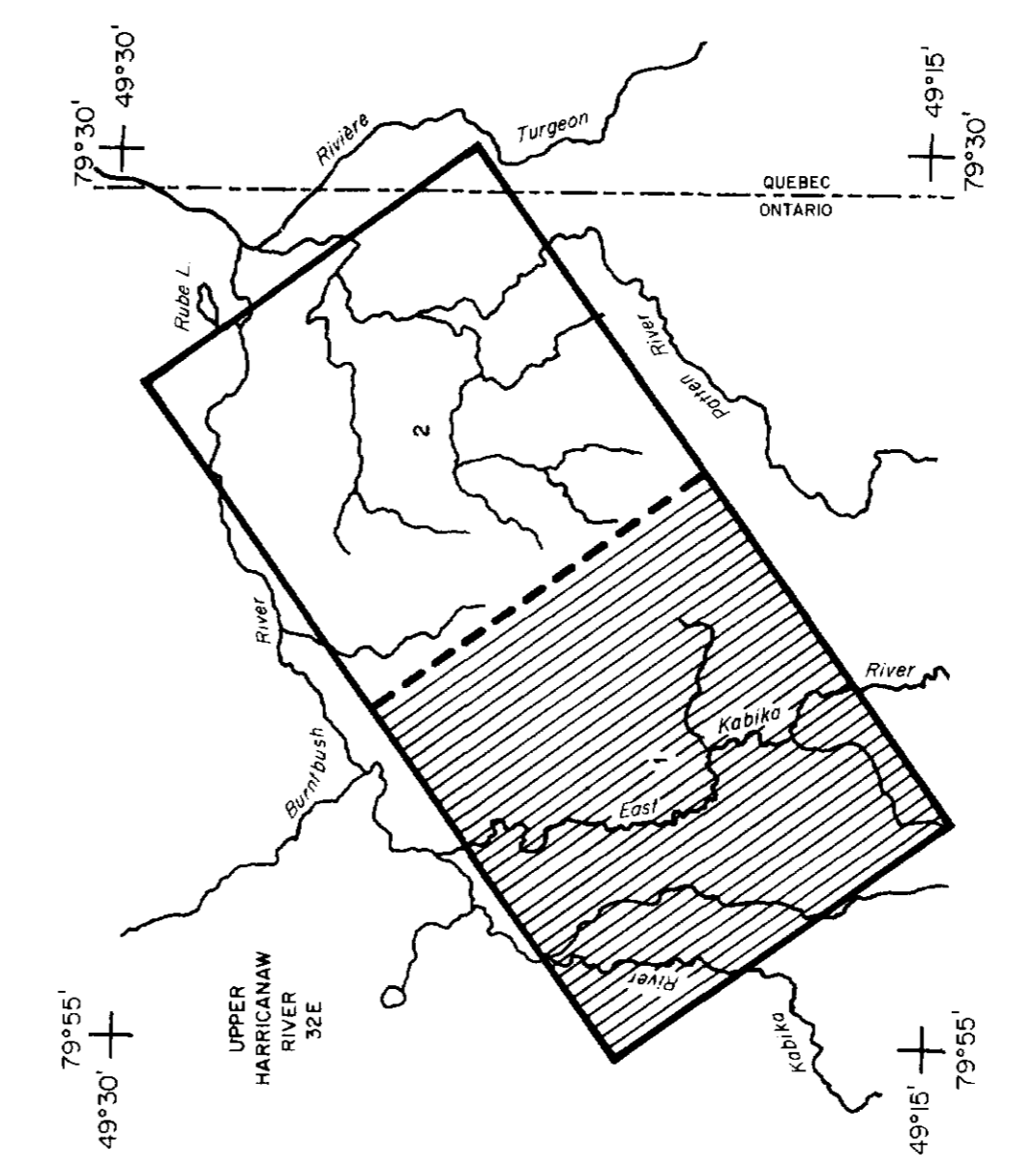

GLEN AUDEN RESOURCES LIMITED  
HURLBISE TOWNSHIP  
PROVINCES OF ONTARIO AND QUEBEC  
SCALE 1:20000

QUESTOR SURVEYS LIMITED  
MISSISSAUGA, ONTARIO, CANADA

FILE NO. 28041  
SHEET NO. 1 OF 2  
DATE NOVEMBER 1986

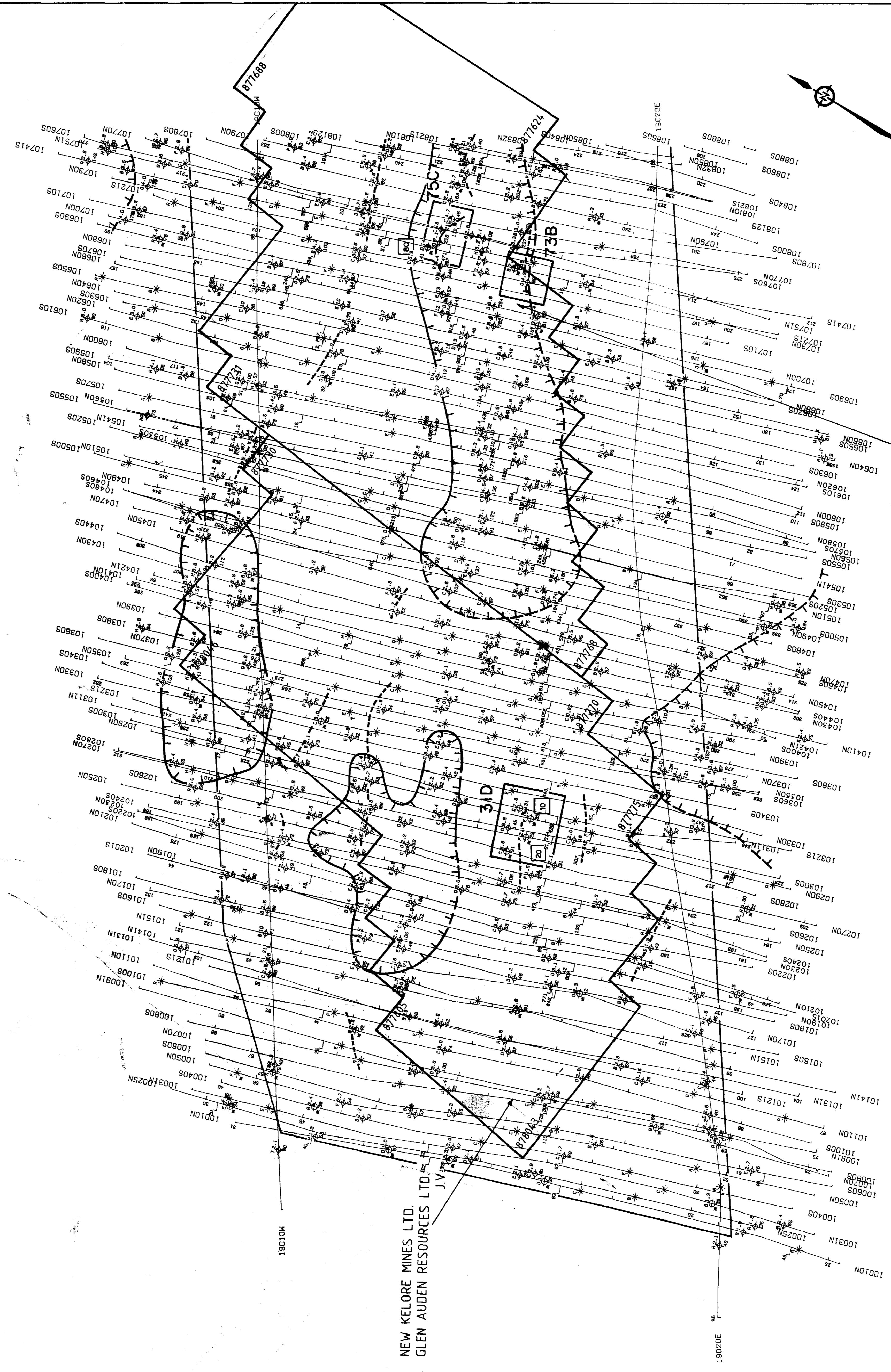

**INPUT PEAK RESPONSE SYMBOLS 2ms PULSE**

RESPONSE CLASSIFICATION

1 Channel (500 microseconds)

2 Channel (500 microseconds)

3 Channel (800 microseconds)

4 Channel (1200 microseconds)

5 Channel (1700 microseconds)

6 Channel (2300 microseconds)

Arrows: North, South, East, West

Amplitude: 10, 20, 30, 40, 50, 60, 70, 80, 90, 100

Phase: 0°, 90°, 180°, 270°

Frequency: 10, 20, 30, 40, 50, 60, 70, 80, 90, 100

**INTERPRETATION**

20 Conductive Zone, with reference number (good definition)

20 Conductive Zone, with reference number (poor definition)

Vertical Conductive Zone

60° Conductive Zone (direction known)

Conductor (Dip) (direction known)

Depth to top of conductor in metres

**Representative INPUT Magnetometer and Allimeter Recording**

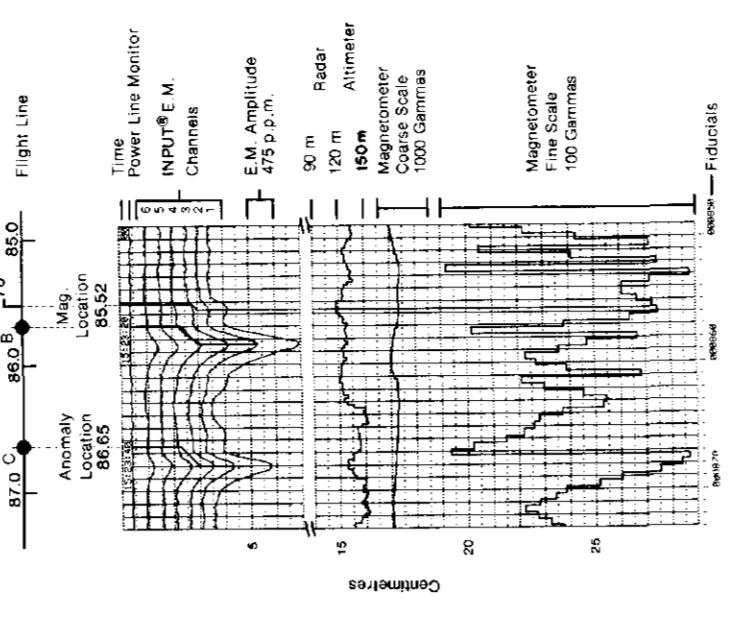

**DESCRIPTIVE NOTES**

The survey is located on the shore of the St. Lawrence River, 10 km north of the mouth of the Saguenay River, in the Township of Hurlbise, County of Beauport, Province of Quebec, Canada. The survey was conducted on 29th October 1984. The survey was conducted by Questor Surveys Limited. The survey was conducted using a magnetometer and allimeter. The survey was conducted using a 2ms pulse. The survey was conducted using a 1000 Hz carrier frequency. The survey was conducted using a 1000 Hz carrier frequency. The survey was conducted using a 1000 Hz carrier frequency.

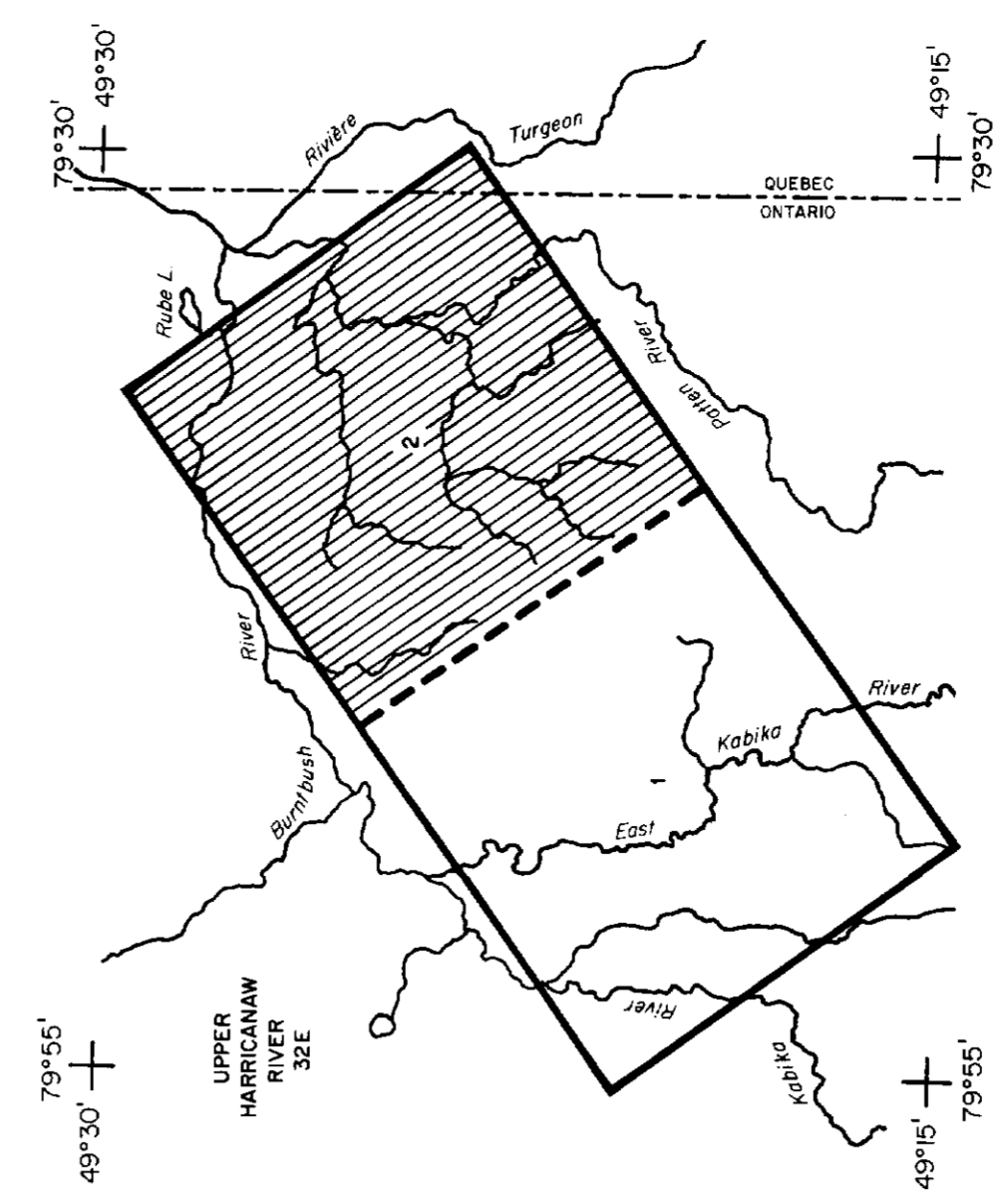

**AIRBORNE MK VI INPUT SURVEY**

GLEN AUDEN RESOURCES LIMITED

**HURTUBISE TOWNSHIP**

PROVINCES OF ONTARIO AND QUEBEC

SCALE 1:20000

QUESTOR SURVEYS LIMITED

W. 181588A, ONTARIO, CANADA

FILE NO. 28041

SHEET NO. 2 OF 2

DATE NOVEMBER 1986

2989

