



41155W0006 0012 AYLNER

010

REPORT ON THE
INDUCED POLARIZATION
AND RESISTIVITY SURVEY
BILLOKI PROPERTY,
AYLMER TOWNSHIP, ONTARIO
FOR
NOVA BEAUCAGE MINES LIMITED

63.1799

McPHAR GEOPHYSICS LIMITED

REPORT ON THE
INDUCED POLARIZATION
AND RESISTIVITY SURVEY
BILLOKI PROPERTY,
AYLMER TOWNSHIP, ONTARIO
FOR
NOVA BEAUCAGE MINES LIMITED

1. INTRODUCTION

As authorized by Nova Beaucage Mines Limited a combined induced polarization and resistivity survey has been carried out over part of the Billoki Property, Aylmer Township, Ontario.

According to available geologic information, the area surveyed is entirely underlain by Gowganda (Cobalt) quartzites which are brecciated in places and locally contain pegmatitic stockworks. The Main Showing, indicated on the accompanying map, occurs in the brecciated quartzite and is described as follows, " The sulphide minerals occur as coarse aggregates reaching a maximum of 1 1/2" across, interstitially to other constituents. At the margins of the showing, and at other points of weaker mineralization, there are veinlets and joint fillings that have a true vein texture of inward-growing crystals, often with a central cavity. Sulphides occur here in the core of the veinlets. "

The sulphides recognized include bornite, chalcopyrite and

pyrite and the maximum assay of a series of samples is 0.64 copper across 8.6 feet.

The purpose of the induced polarization survey was to check the area surrounding the known mineralization for a sizable body of disseminated material.

The field surveying was carried out during March 1965.

2. PRESENTATION OF RESULTS

The induced polarization and resistivity results are shown on the enclosed data plots in the manner outlined in the notes preceding this report. The dipole-dipole configuration, with an electrode separation of 200 feet, was used for all of the surveying.

Line	Dwg. I.P. No.
14W	2229-1
12W	2229-2
10W	2229-3
8W	2229-4
6W	2229-5
4W	2229-6
2W	2229-7
0	2229-8
2E	2229-9
4E	2229-10
6E	2229-11
8E	2229-12

Enclosed with this report is Dwg. Misc. 3070, a plan map of part of the property, at a scale of 1" = 200 feet. The definite and possible induced polarization anomalies are indicated by solid and broken bars respectively on this plan map as well as the data plots. These bars represent the surface projection of the anomalous zones as interpreted from the location of the transmitter and receiver electrodes when the anomalous values were measured.

Since the induced polarization measurement is essentially an averaging process, as are all potential methods, it is frequently difficult to exactly pinpoint the source of an anomaly. Certainly, no anomaly can be located with more accuracy than the spread length; i. e. when using 200' spreads the position of a narrow sulphide body can only be determined to lie between two stations 200' apart. In order to locate sources at some depth, larger spreads must be used, with a corresponding increase in the uncertainties of location. Therefore, while the center of the indicated anomaly probably corresponds fairly well with source, the length of the indicated anomaly along the line should not be taken to represent the exact edges of the anomalous material.

3. DISCUSSION OF RESULTS

In general, the resistivities encountered in the survey are greater than 10,000 ohm feet, and the Metal Factor values are quite small. In areas of high resistivity, small Metal Factors can represent significant amounts of sulphide and for this reason unusually small IP effects have been interpreted as being anomalous.

Lines 8W, 10W, 12W and 14W

There are slight increases in the Metal Factor values on the north and south ends of the data plots for 8W and 10W. However, none of the IP effects on these four lines is considered to be significant.

Line 6W

A probable IP anomaly is shown between 6N and 8N. It appears to be due to a source that is remote from the line; (i. e. either at depth, or to the side of the traverse line.)

This anomaly correlates with a stronger indication on Line 4W and together they suggest a source that plunges to the northwest. An alternative interpretation would be that the Metal Factor values on Line 6W are due to side effects of the source on Line 4W.

Line 4W

The strongest IP response encountered in the survey is centered just north of 6N on this line. The contour pattern indicates a source of fairly concentrated metallic material with some depth to its top. An accurate estimate of the depth of the source is difficult, but the strongest portion of the source would be expected to lie within 200 feet of the surface.

There is a weak indication of shallow and less concentrated material between 2N and 4N. This anomaly could be the up dip continuation of the stronger source discussed above.

Line 2W

A probable anomaly is shown from 2N to 6N on this line. It

appears to represent a rather broad source of low metallic content that is not deeply buried. The contour pattern indicates that the source could extend farther north and south at depth.

This weak response lies immediately north of the Main Showing and could represent an area of similar weak mineralization.

Lines 0, 2E and 4E

Two weak possible anomalous zones are shown on the data plot for Line 2E. These may represent shallow zones of low metallic content, but are considered to be of minor importance.

The remainder of the data on these three lines is essentially negative.

Lines 6E and 8E

There are weak indications of deep sources on these two lines. Further investigation of these anomalies is not considered warranted on the basis of the IP results alone. However, if encouraging mineralization is encountered elsewhere on the property, these anomalies would require re-assessment.

4. SUMMARY AND RECOMMENDATIONS

The induced polarization results do not indicate any large near-surface deposits of either massive or heavily disseminated sulphides. With the 200 foot electrode separation used and the n=1, 2, 3 and 4 observations taken, the effective depth of exploration is estimated to be about 400 feet.

However, there is a small, but quite concentrated source centered just north of 6N on Line 4W that appears to be located at depth. The prevailing high resistivities encountered on the property make any estimate of the percentage sulphide content quite difficult. The source could be a body up to 200 feet across containing 5%, or perhaps even 10%, sulphides. Alternately, the measured effects could be caused by a narrower, but more concentrated source. The IP effects on Line 4W indicate that the source either plunges steeply to the northwest or terminates between Lines 4W and 6W.

Further investigation of the area surveyed does not appear to be warranted on the basis of the induced polarization survey. However, if the geologic setting is considered to be favourable, one or two test holes should be drilled to test the best IP indication on Line 6W.

The weak IP anomalies are believed to be of minor importance and do not warrant further consideration unless economic mineralization is encountered elsewhere on the property.

McPHAR GEOPHYSICS LIMITED

D. B. Sutherland

D. B. Sutherland,
Geophysicist.

Robert A. Bell

Robert A. Bell,
Geologist.

Dated: March 19, 1965

ASSESSMENT DETAILS

PROPERTY: Billocki Property

MINING DIVISION: Sudbury

SPONSOR: Nova Beaucage

PROVINCE: Ontario

LOCATION: Aylmer Township

TYPE OF SURVEY: Induced Polarization

OPERATING MAN DAYS: 43.0 DATE STARTED: February 14, 1965

EQUIVALENT 8 HR MAN DAYS: 64.5 DATE FINISHED: March 6, 1965

CONSULTING MAN DAYS: 2.0 NUMBER OF STATIONS Occupied: 106

DRAUGHTING MAN DAYS: 2 NUMBER OF READINGS TAKEN: 656

TOTAL MAN DAYS: 68.5 MILES OF LINE SURVEYED: 3.5

CONSULTANTS:

D. B. Sutherland, Apartment 604, 412 Eglinton Ave. E., Toronto 12, Ontario

FIELD TECHNICIANS:

M. Castonguay, 133 Sorcauren Ave., Toronto 3, Ontario

R. Fernholme, c/o George Fernholme, Halleybury, Ontario

2 Helpers:

A. J. McLeod)
J. Cavity) General Delivery, Capreol, Ontario

DRAUGHTSMEN:

S. Woods, 1222 York Mills Rd., Apt. 401, Don Mills, Ontario

K. Bingham, 78 Hubbard Boulevard, Toronto 13, Ontario

E. Helkio, 17 Annaree St., Scarborough, Ontario

McPHAR GEOPHYSICS LIMITED

Robert A. Bell
Robert A. Bell,
Geologist

D. B. Sutherland
D. B. Sutherland, *for R.A.*
Geophysicist

Dated: March 19, 1965

McPHAR GEOPHYSICS LIMITED

NOTES ON THE THEORY OF INDUCED POLARIZATION AND THE METHOD OF FIELD OPERATION

Induced Polarization as a geophysical measurement refers to the blocking action or polarization of metallic or electronic conductors in a medium of ionic solution conduction.

This electro-chemical phenomenon occurs wherever electrical current is passed through an area which contains metallic minerals such as base metal sulphides. Normally, when current is passed through the ground, as in resistivity measurements, all of the conduction takes place through ions present in the water content of the rock, or soil, i. e. by ionic conduction. This is because almost all minerals have a much higher specific resistivity than ground water. The group of minerals commonly described as "metallic", however, have specific resistivities much lower than ground waters. The induced polarization effect takes place at those interfaces where the mode of conduction changes from ionic in the solutions filling the interstices of the rock to electronic in the metallic minerals present in the rock.

The blocking action or induced polarization mentioned above, which depends upon the chemical energies necessary to allow the ions to give up or receive electrons from the metallic surface, increases with the time that a d. c. current is allowed to flow through

the rock; i. e. as ions pile up against the metallic interface the resistance to current flow increases. Eventually, there is enough polarization in the form of excess ions at the interfaces to effectively stop all current flow through the metallic particle. This polarization takes place at each of the infinite number of solution-metal interfaces in a mineralized rock.

When the d. c. voltage used to create this d. c. current flow is cut off, the Coulomb forces between the charged ions forming the polarization cause them to return to their normal position. This movement of charge creates a small current flow which can be measured on the surface of the ground as a decaying potential difference.

From an alternate viewpoint it can be seen that if the direction of the current through the system is reversed repeatedly before the polarization occurs, the effective resistivity of the system as a whole will change as the frequency of the switching is changed. This is a consequence of the fact that the amount of current flowing through each metallic interface depends upon the length of time that current has been passing through it in one direction.

The values of the "metal factor" or "M. F." are a measure of the amount of polarization present in the rock mass being surveyed. This parameter has been found to be very successful in mapping areas of sulphide mineralization, even those in which all other geophysical methods have been unsuccessful. The induced polarization measurement is more sensitive to sulphide content than other electrical measurements

oxides such as magnetite, pyrolusite, chromite, and some forms of hematite also conduct by electrons and are metallic. All of the metallic minerals in the rock will contribute to the induced polarization effect measured on the surface.

In the field procedure, measurements on the surface are made in a way that allows the effects of lateral changes in the properties of the ground to be separated from the effects of vertical changes in the properties. Current is applied to the ground at two points a distance (X) apart. The potentials are measured at two other points (X) feet apart, in line with the current electrodes. The distance between the nearest current and potential electrodes is an integer number (N) times the basic distance (X).

The measurements are made along a surveyed line, with a ~~constant~~ distance (NX) between the nearest current and potential electrodes. In most surveys, several traverses are made with various values of (N); i. e. (N) = 1, 2, 3, 4, etc. The kind of survey required (detailed or reconnaissance) decides the number of values of (N) used.

In plotting the results, the values of the apparent resistivity and the apparent metal factor measured for each set of electrode positions are plotted at the intersection of grid lines, one from the center point of the current electrodes and the other from the center point of the potential electrodes. The resistivity values are plotted above the line and the metal factor values below. The lateral displacement of a given value is determined by the location along the survey

because it is much more dependent upon the sulphide content. As the sulphide content of a rock is increased, the "metal factor" of the rock increases much more rapidly than the resistivity decreases.

Because of this increased sensitivity, it is possible to locate and outline zones of less than 10% sulphides that can't be located by E. M. Methods. The method has been successful in locating the disseminated "porphyry copper" type mineralization in the South-western United States.

Measurements and experiments also indicate that it should be possible to locate most massive sulphide bodies at a greater depth with induced polarization than with E. M.

Since there is no I. P. effect from any conductor unless it is metallic, the method is useful in checking E. M. anomalies that are suspected of being due to water filled shear zones or other ionic conductors. There is also no effect from conductive overburden, which frequently confuses E. M. results. It would appear from scale model experiments and calculations that the apparent metal factors measured over a mineralized zone are larger if the material overlying the zone is of low resistivity.

Apropos of this, it should be stated that the induced polarization measurements indicate the total amount of metallic constituents in the rock. Thus all of the metallic minerals in the rock, such as pyrite, as well as the ore minerals chalcopyrite, chalcocite, galena, etc. are responsible for the induced polarization effect. Some

oxides such as magnetite, pyrolusite, chromite, and some forms of hematite also conduct by electrons and are metallic. All of the metallic minerals in the rock will contribute to the induced polarization effect measured on the surface.

In the field procedure, measurements on the surface are made in a way that allows the effects of lateral changes in the properties of the ground to be separated from the effects of vertical changes in the properties. Current is applied to the ground at two points a distance (X) apart. The potentials are measured at two other points (X) feet apart, in line with the current electrodes. The distance between the nearest current and potential electrodes is an integer number (N) times the basic distance (X).

The measurements are made along a surveyed line, with a constant distance (NX) between the nearest current and potential electrodes. In most surveys, several traverses are made with various values of (N); i. e. (N) = 1, 2, 3, 4, etc. The kind of survey required (detailed or reconnaissance) decides the number of values of (N) used.

In plotting the results, the values of the apparent resistivity and the apparent metal factor measured for each set of electrode positions are plotted at the intersection of grid lines, one from the center point of the current electrodes and the other from the center point of the potential electrodes. The resistivity values are plotted above the line and the metal factor values below. The lateral displacement of a given value is determined by the location along the survey

line of the center point between the current and potential electrodes. The distance of the value from the line is determined by the distance (NX) between the current and potential electrodes when the measurement was made.

The separation between sender and receiver electrodes is only one factor which determines the depth to which the ground is being sampled in any particular measurement. These plots then, when contoured, are not section maps of the electrical properties of the ground under the survey line. The interpretation of the results from any given survey must be carried out using the combined experience gained from field, model and theoretical investigations. The position of the electrodes when anomalous values are measured must be used in the interpretation.

In the field procedure, the interval over which the potential differences are measured is the same as the interval over which the electrodes are moved after a series of potential readings has been made. One of the advantages of the induced polarization method is that the same equipment can be used for both detailed and reconnaissance surveys merely by changing the distance (X) over which the electrodes are moved each time. In the past, intervals have been used ranging from 100 feet to 1000 feet for (X). In each case, the decision as to the distance (X) and the values of (N) is largely determined by the expected size of the mineral deposit being sought, the size of the expected anomaly and the speed with which it is desired to progress.

The diagram in Figure 1 below demonstrates the method used in plotting the results. Each value of the apparent resistivity and the apparent "Metal factor" is plotted and identified by the position of the four electrodes when the measurement was made. It can be seen that the values measured for the larger values of (n) are plotted farther from the line indicating that the thickness of the layer of the earth that is being tested is greater than for the smaller values of (n); i. e. the depth of the measurement is increased.

METHOD USED IN PLOTTING DIPOLE-DIPOLE
INDUCED POLARIZATION AND RESISTIVITY RESULTS

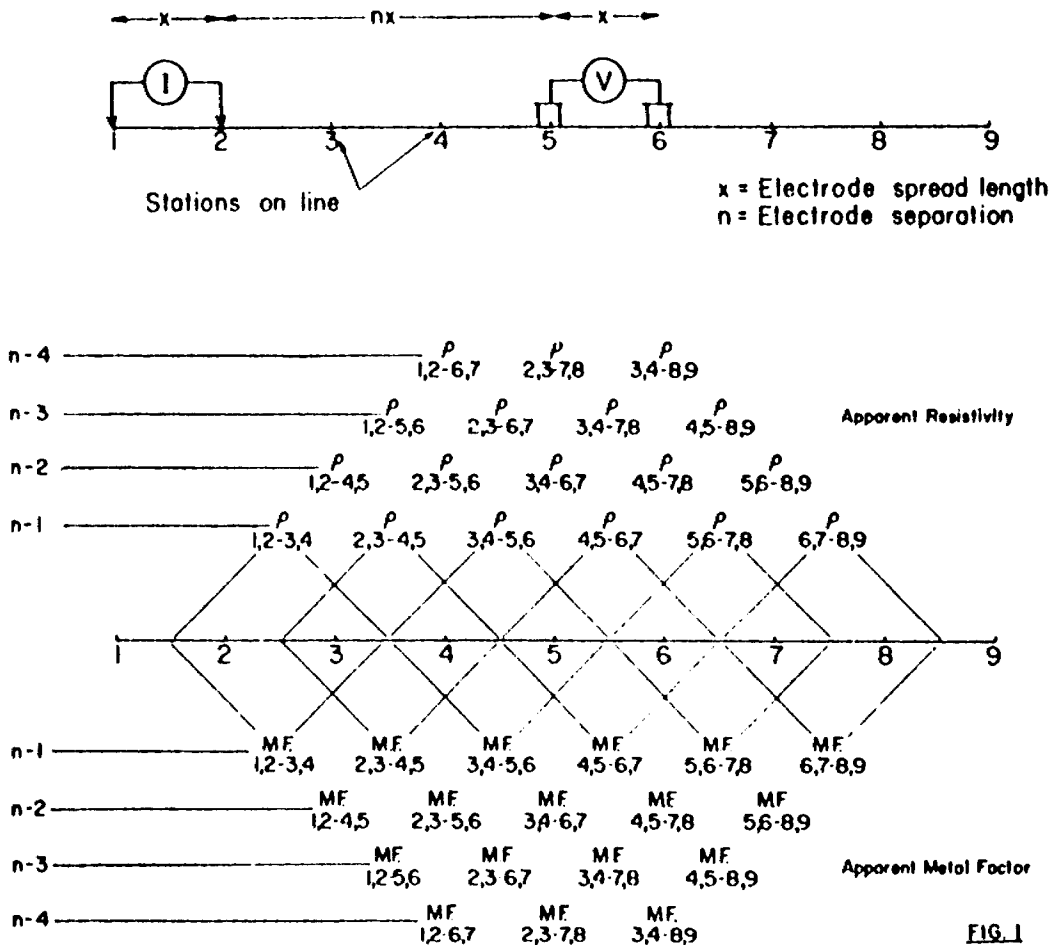
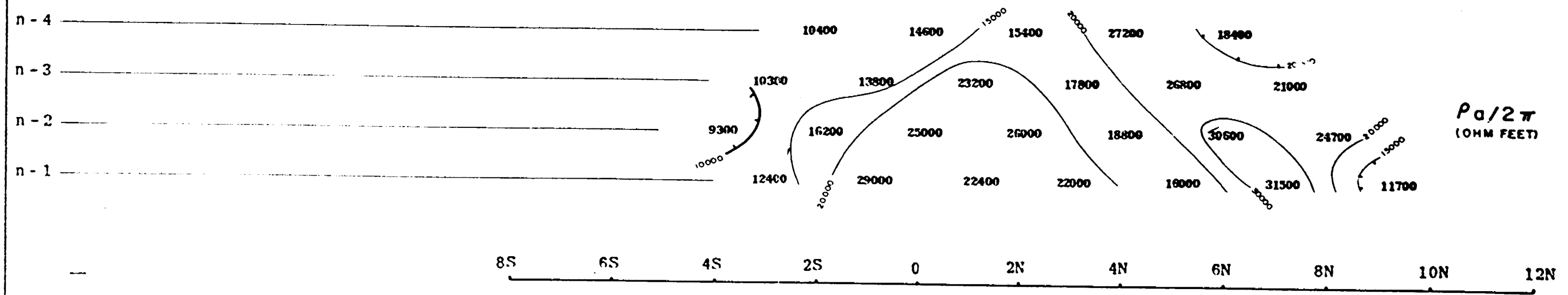
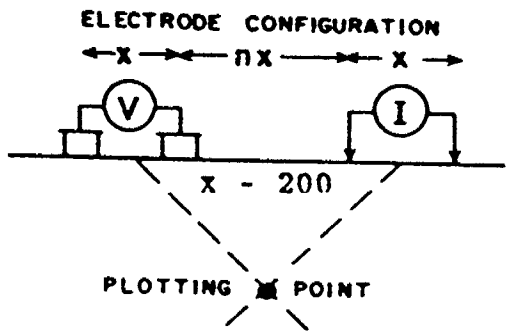

FIG. 1

McPHAR GEOPHYSICS LIMITED

INDUCED POLARIZATION AND RESISTIVITY SURVEY



n - 1			0.1	0.1	0.1	0	0.1	0	0.3	
n - 2		0.4	0.1	0.1	0	0.1	0	0.1		
n - 3		0.4	0.1	0	0.1	0	0.1			(M.F.) a
n - 4			0.4	0.1	0.1	0	0.1			

SURFACE PROJECTION OF ANOMALOUS ZONES

DEFINITE

PROBABLE

POSSIBLE

NOVA BEAUCAGE MINES LIMITED
 BILLOCKI PROPERTY, AYLMER TWP. - SUDBURY M. D. ONTARIO
 Scale - One inch = 200 Feet

NOTE LOGARITHMIC CONTOUR INTERVAL

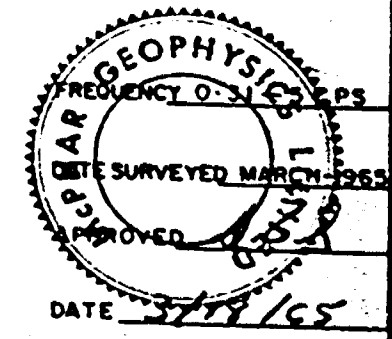

LINE NO. - 14 W

McPHAR GEOPHYSICS LIMITED

INDUCED POLARIZATION AND RESISTIVITY SURVEY

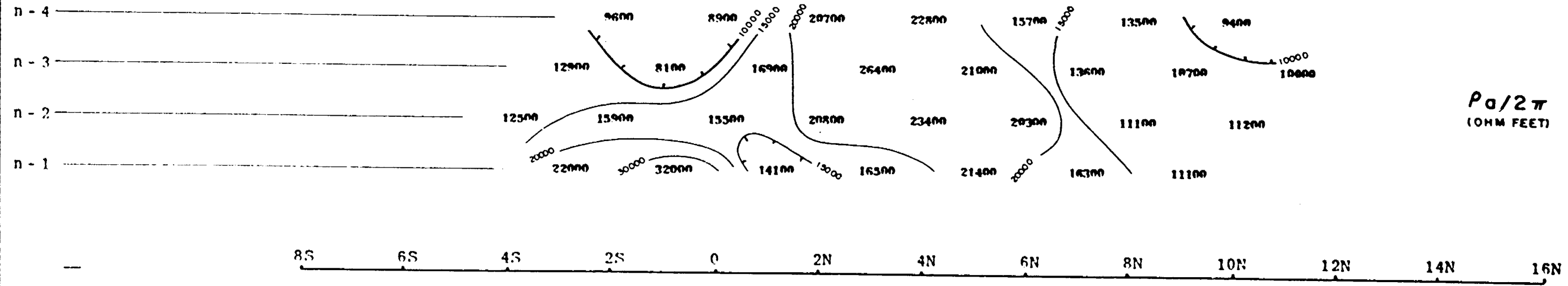
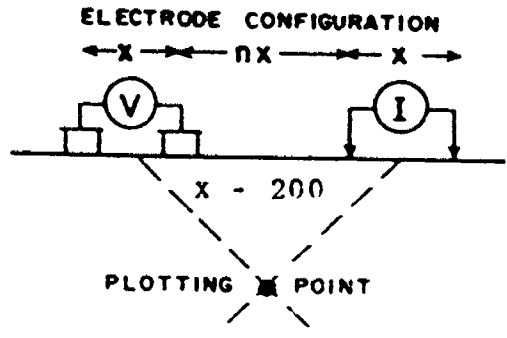

n - 1		0.2	0	0.2	0.1	0.1	0.1	0.1	
n - 2		0.2	0.1	0.2	0.1	0.1	0.2	0.2	0.3
n - 3		0.2	0.3	0.1	0.1	0	0.1	0.3	0.3
n - 4		0.3	0.4	0.1	0.1	0.1	0.1	0.1	0.3

(M.F.) σ

SURFACE PROJECTION OF ANOMALOUS ZONES

DEFINITE

PROBABLE

POSSIBLE

NOVA BEAUCAGE MINES LIMITED
 BILLOCKI PROPERTY, AYLMER TWP. - SUDBURY M. D. ONTARIO

Scale - One inch = 200 Feet

NOTE: LOGARITHMIC CONTOUR INTERVAL

LINE NO. - 12 W

McPHAR GEOPHYSICS LIMITED

INDUCED POLARIZATION AND RESISTIVITY SURVEY

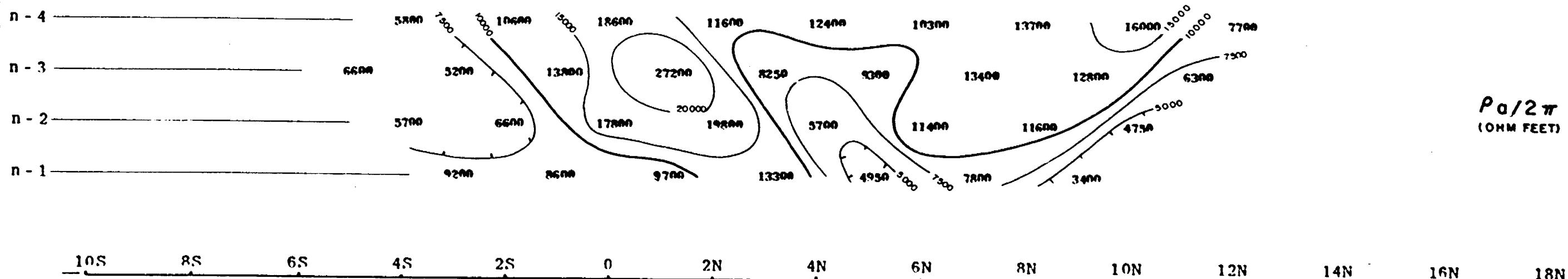
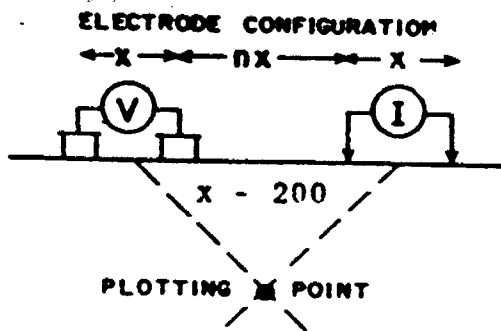

n - 1		0.5	0.5	0.2	0.2	0.4	0.2	0.9						
n - 2		1	0.3	0.3	0.1	0.4	0.2	0.2	1					
n - 3	0.7	0.6	0.1	0.1	0.4	0.1	0.2	0.3	1					
n - 4		0.5	0.3	0.1	0.5	0.1	0.3	0.3	0.1	0.8				

(M.F.) 0

SURFACE PROJECTION OF ANOMALOUS ZONES

DEFINITE

PROBABLE

POSSIBLE

NOVA BEAUCAGE MINES LIMITED
 BILLOCKI PROPERTY, AYLMER TWP. - SUDBURY M.D. ONTARIO
 Scale - One inch = 200 Feet

NOTE LOGARITHMIC CONTOUR INTERVAL

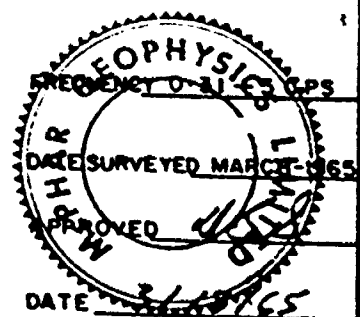

LINE NO. - 10 W

McPHAR GEOPHYSICS LIMITED

INDUCED POLARIZATION AND RESISTIVITY SURVEY

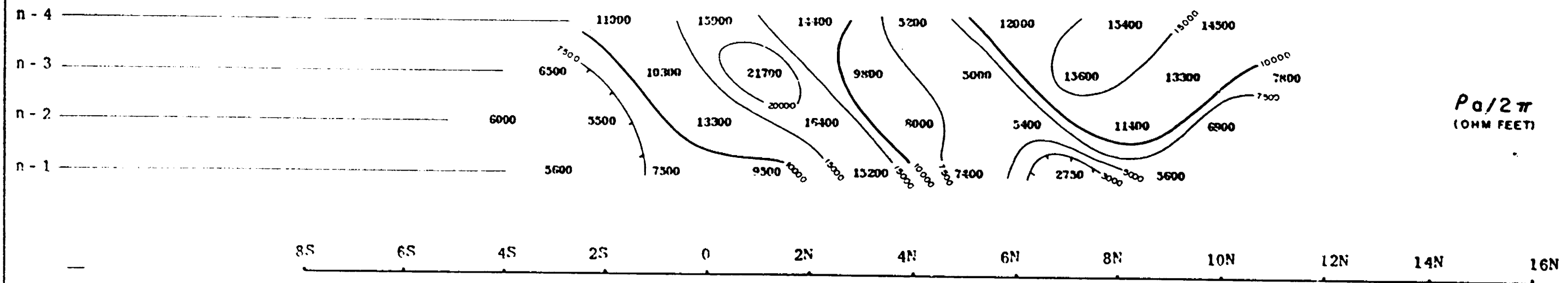
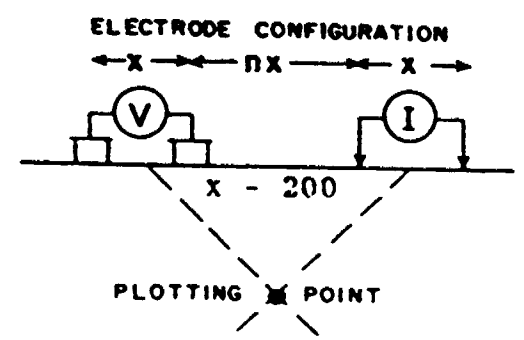

n - 1		0.9	0.7	0.2	0.1	0.1	0.6	0.2				
n - 2		0.7	0.6	0.3	0.1	0.4	0.4	0.3	0.9			
n - 3		0.7	0.3	0.2	0.3	0.6	0.2	0.4	0.9			
n - 4		0.2	0.1	0.3	0.7	0.2	0.2	0.2				

(M. F.) a

SURFACE PROJECTION OF ANOMALOUS ZONES

DEFINITE

PROBABLE

POSSIBLE

NOVA BEAUCAGE MINES LIMITED
 BILLOCKI PROPERTY, AYLMEY TWP. - SUDBURY M.D. ONTARIO

Scale - One inch = 200 Feet

NOTE LOGARITHMIC CONTOUR INTERVAL

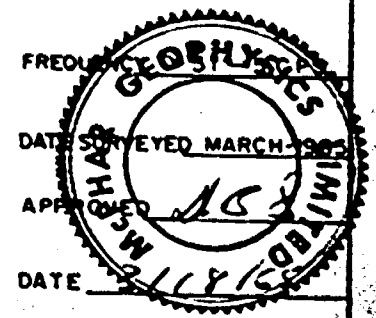

62.1799

LINE NO. - 8 W

McPHAR GEOPHYSICS LIMITED

INDUCED POLARIZATION AND RESISTIVITY SURVEY

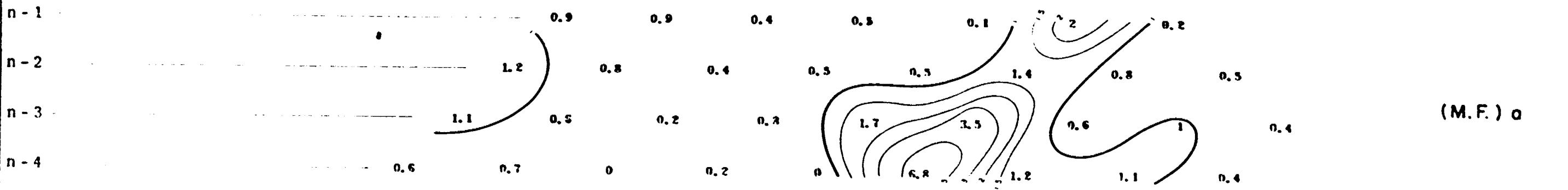
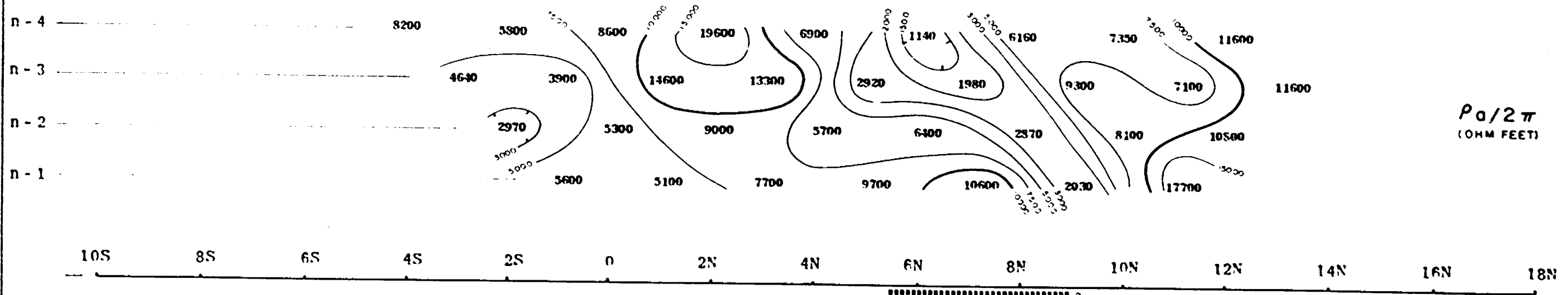
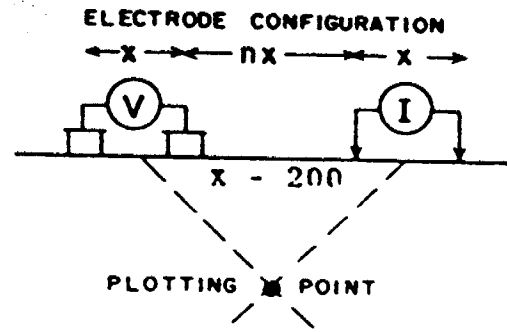

SURFACE PROJECTION OF ANOMALOUS ZONES

- DEFINITE
- PROBABLE
- POSSIBLE

NOVA BEAUCAGE MINES LIMITED

BILLOCKI PROPERTY, AYLMER TWP. - SUDBURY M.D. ONTARIO

Scale - One inch = 200 Feet

NOTE LOGARITHMIC CONTOUR INTERVAL

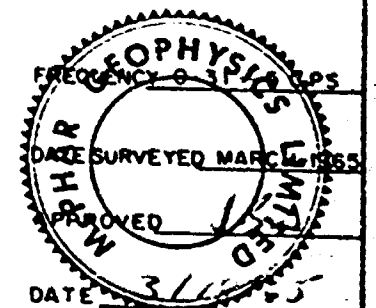

LINE NO. - 6 W

McPHAR GEOPHYSICS LIMITED

INDUCED POLARIZATION AND RESISTIVITY SURVEY

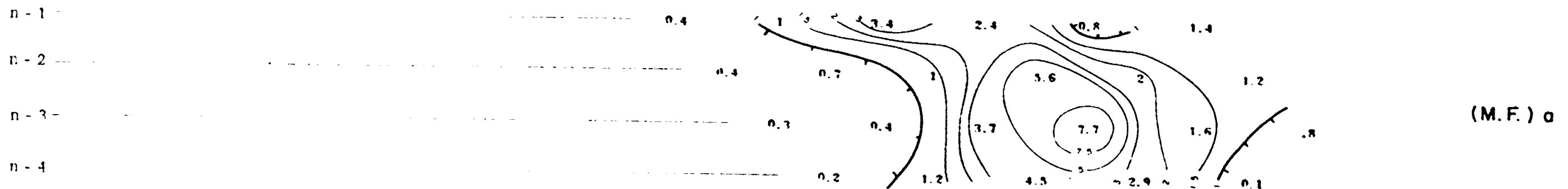
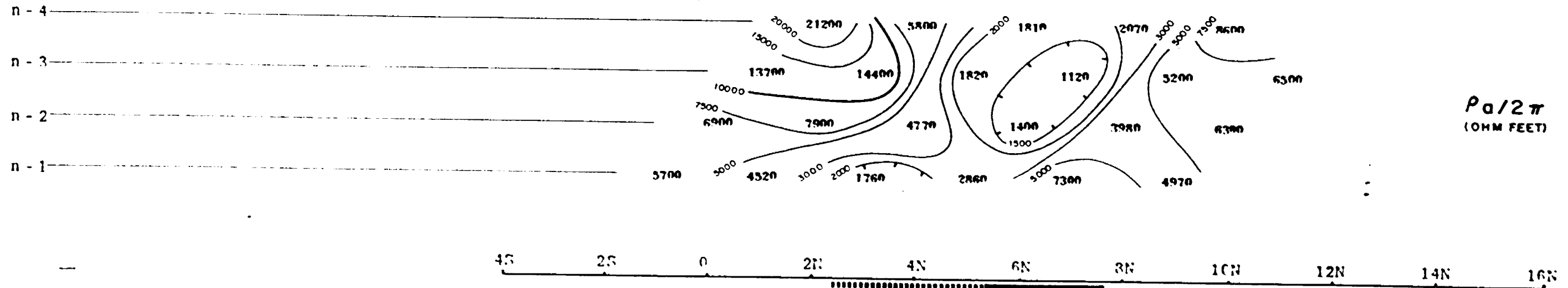
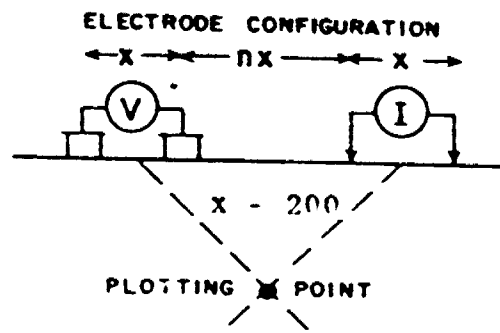

SURFACE PROJECTION
OF ANOMALOUS ZONES

- DEFINITE
- PROBABLE
- POSSIBLE

NOVA BEAUCAGE MINES LIMITED

BILLOCKI PROPERTY, AYLMER TWP. - SUDBURY M.D. ONTARIO

Scale - One inch = 200 Feet

NOTE LOGARITHMIC CONTOUR INTERVAL

FREQUENCY

DATE SURVEYED MARCH-1966

APPROVED

DATE 3/18/65

63.1799

LINE NO. - 4 W

McPHAR GEOPHYSICS LIMITED

INDUCED POLARIZATION AND RESISTIVITY SURVEY

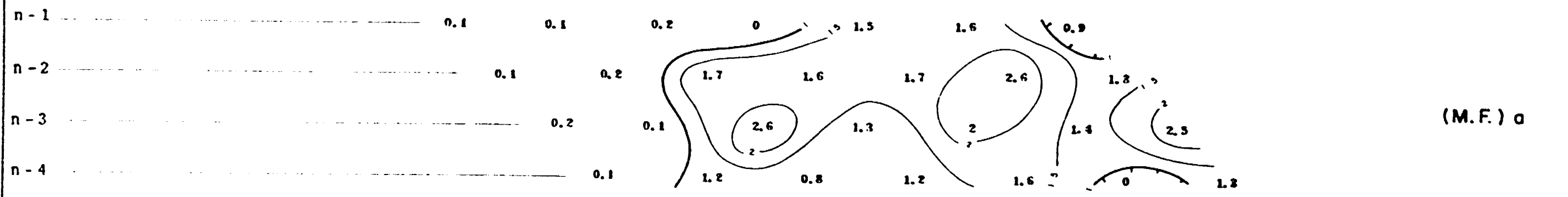
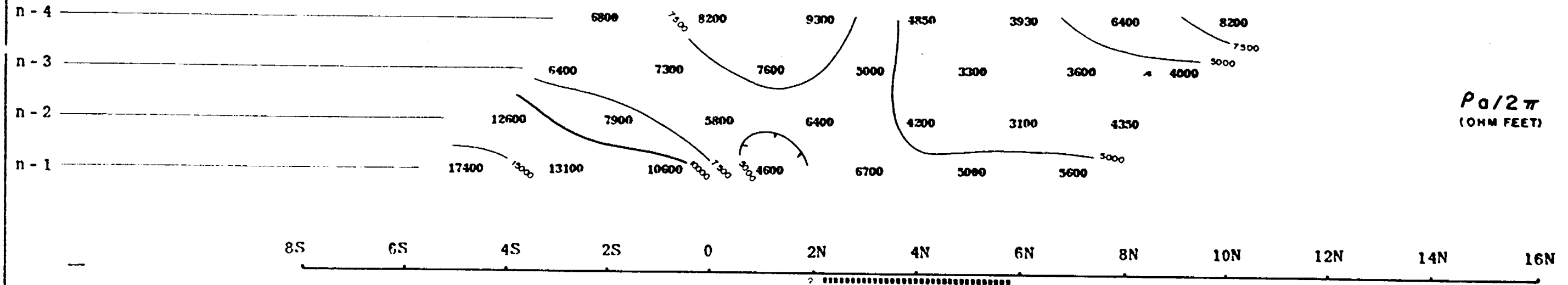
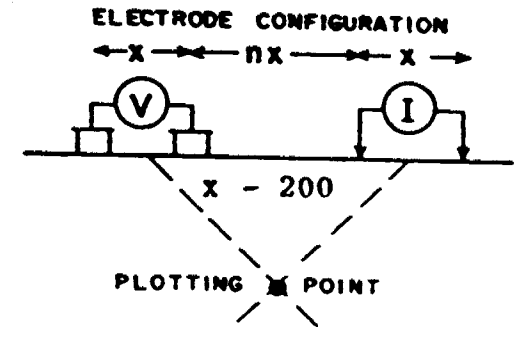

SURFACE PROJECTION OF ANOMALOUS ZONES

DEFINITE

PROBABLE

POSSIBLE

NOVA BEAUCAGE MINES LIMITED
 BILLOCKI PROPERTY, AYLMER TWP. - SUDBURY M.D. ONTARIO
 Scale - One inch = 200 Feet

NOTE LOGARITHMIC CONTOUR INTERVAL

FREQUENCY

DATE SURVEYED MARCH-1969

APPROVED

DATE 3/18/69

1.2.1799

LINE NO. - 2 W

McPHAR GEOPHYSICS LIMITED

INDUCED POLARIZATION AND RESISTIVITY SURVEY

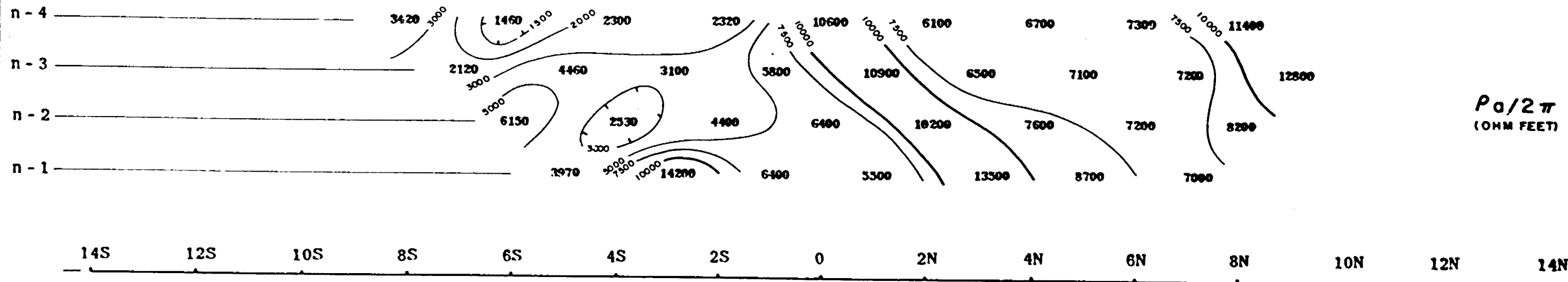
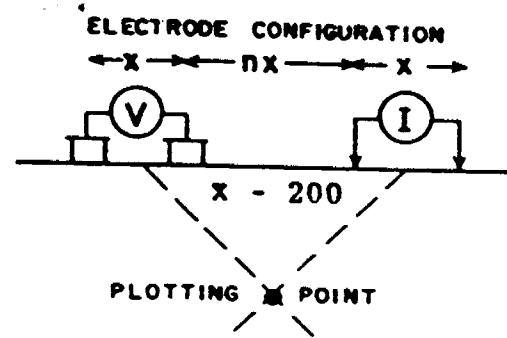

n - 1		0.4	0.1	0.2	0.5	0.2	0.2	0.3										
n - 2		0.2	0.4	0.2	0.4	0.4	0.4	0.4	0.4	0.4	0.4	0.4	0.4	0.4	0.4	0.4	0.4	0.4
n - 3		0.6	0.3	0.4	0.5	0.4	0.5	0.4	0.5	0.6	0.4	0.4	0.3					
n - 4		0.4	0.8	0	0.9	0.4	0.6	0.5	0.6	0.6	0.6	0.6	0.3					

(M.F.) 0

SURFACE PROJECTION OF ANOMALOUS ZONES

DEFINITE

PROBABLE

POSSIBLE

NOVA BEAUCAGE MINES LIMITED
 BILLOCKI PROPERTY, AYLMER TWP. - SUDBURY M. D. ONTARIO

Scale - One inch = 200 Feet

NOTE LOGARITHMIC CONTOUR INTERVAL

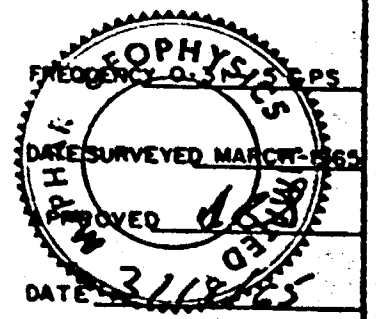

LINE NO. - 0

McPHAR GEOPHYSICS LIMITED

INDUCED POLARIZATION AND RESISTIVITY SURVEY

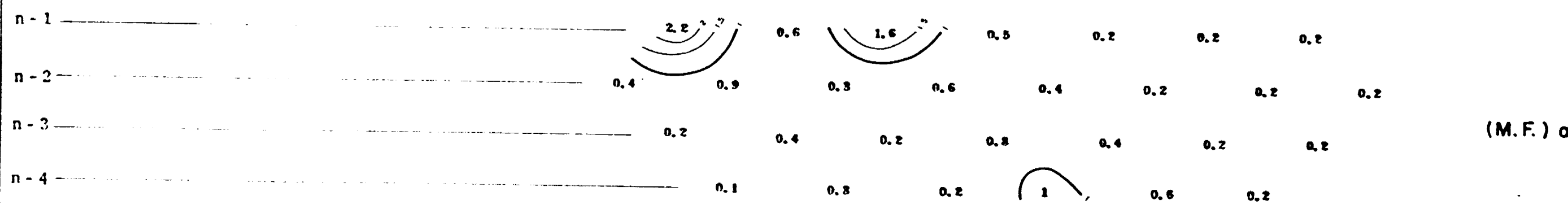
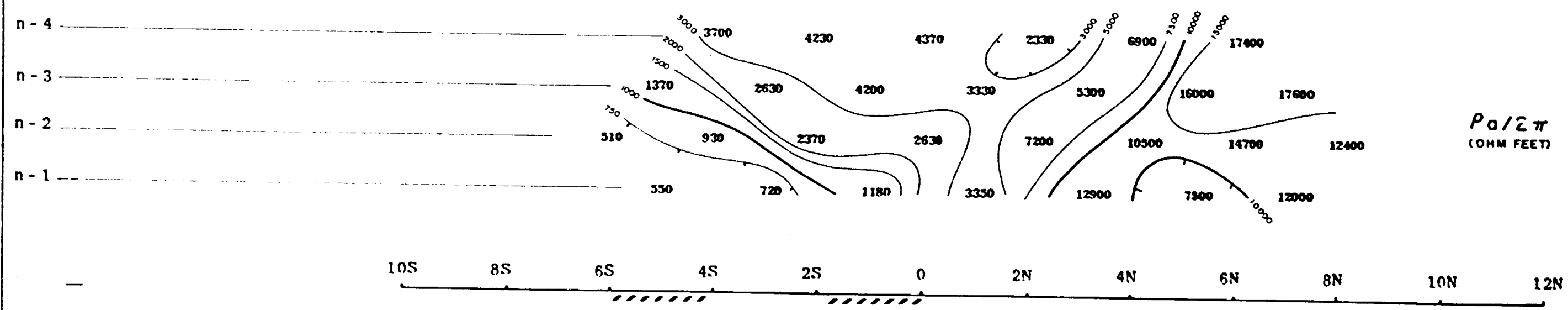
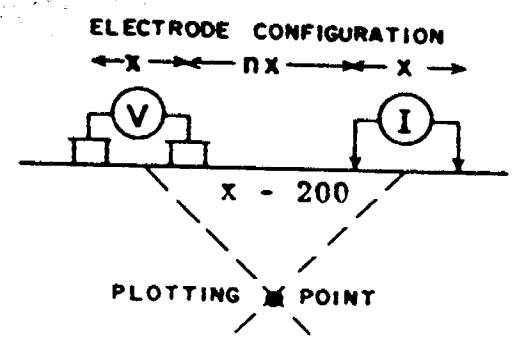

SURFACE PROJECTION OF ANOMALOUS ZONES

DEFINITE

PROBABLE

POSSIBLE

NOVA BEAUCAGE MINES LIMITED
 BILLOCKI PROPERTY, AYLMEYR TWP. - SUDBURY M.D. ONTARIO

Scale - One inch = 200 Feet

NOTE LOGARITHMIC CONTOUR INTERVAL

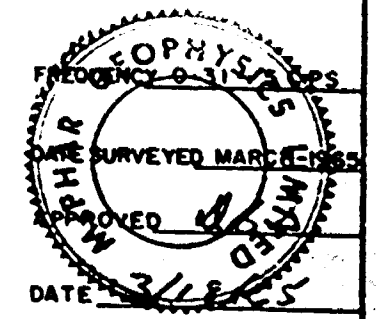

LINE NO. - 2 E

McPHAR GEOPHYSICS LIMITED

INDUCED POLARIZATION AND RESISTIVITY SURVEY

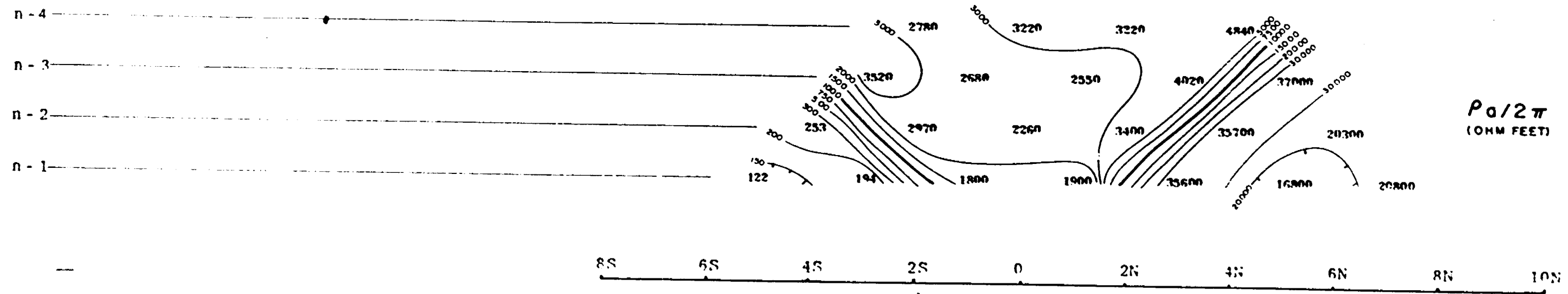
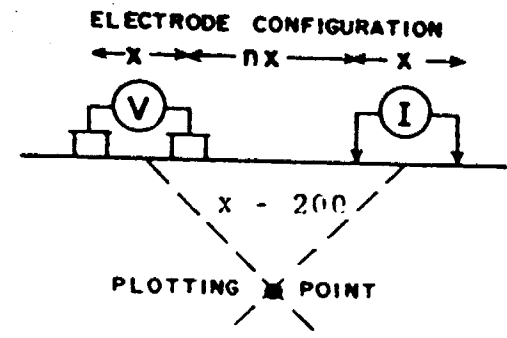

n - 1		0	0.5	0.1	0.2	0.1	0.1	0.1
n - 2		0	0	0	0.3	0.1	0.2	
n - 3		0	0.4	0.4	0.4	0.1		
n - 4		0	0.4	0.7	0.6			

(M.F.) a

SURFACE PROJECTION OF ANOMALOUS ZONES
 DEFINITE
 PROBABLE
 POSSIBLE

NOVA BEAUCAGE MINES LIMITED
 BILLOCKI PROPERTY, AYLMER TWP. - SUDBURY M.D. ONTARIO
 Scale - One inch = 200 Feet

NOTE LOGARITHMIC CONTOUR INTERVAL

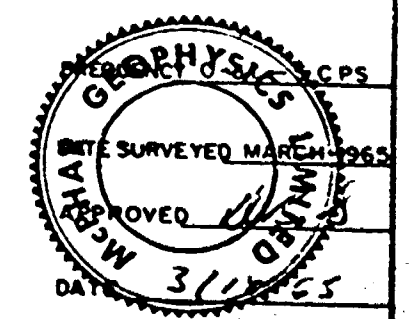

LINE NO. - 4 E

1799

McPHAR GEOPHYSICS LIMITED

INDUCED POLARIZATION AND RESISTIVITY SURVEY

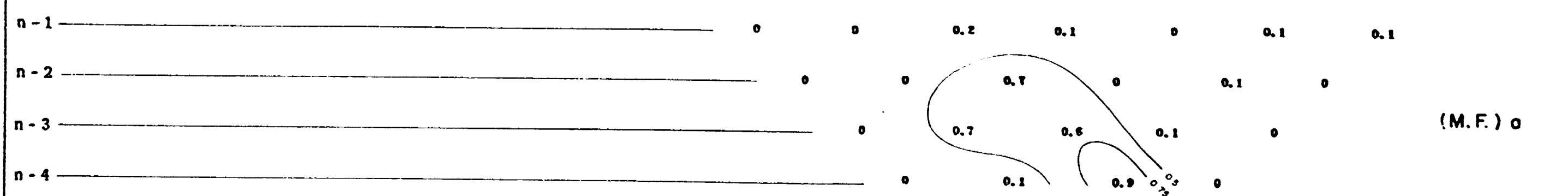
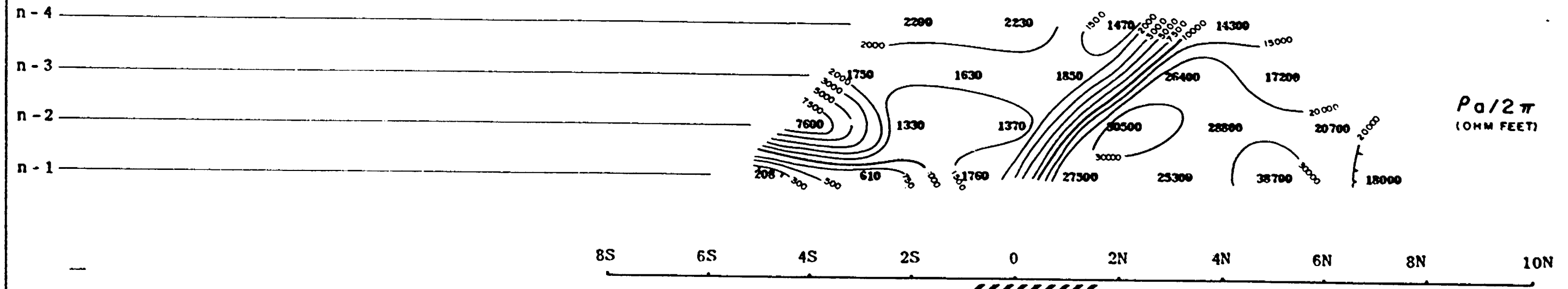
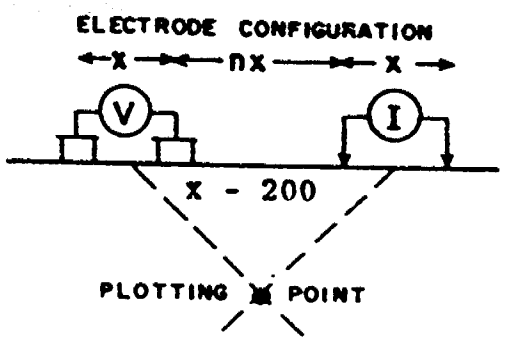

SURFACE PROJECTION OF ANOMALOUS ZONES

DEFINITE

PROBABLE

POSSIBLE

NOVA BEAUCAGE MINES LIMITED
 BILLOCKI PROPERTY, AYLMEER TWP. - SUDBURY M. D. ONTARIO
 Scale - One inch = 200 Feet

NOTE: LOGARITHMIC CONTOUR INTERVAL

FREQUENCY

DATE SURVEYED MARCH - 1966

APPROVED

DATE 3/18/66

LINE NO. - 6 E

McPHAR GEOPHYSICS LIMITED

INDUCED POLARIZATION AND RESISTIVITY SURVEY

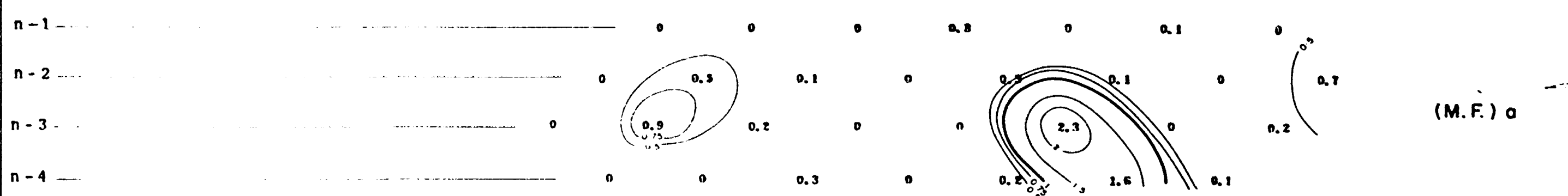
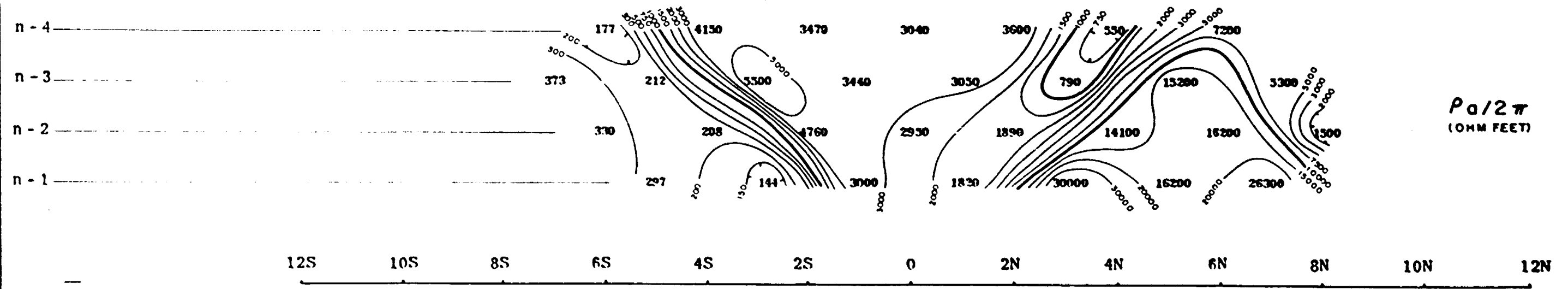
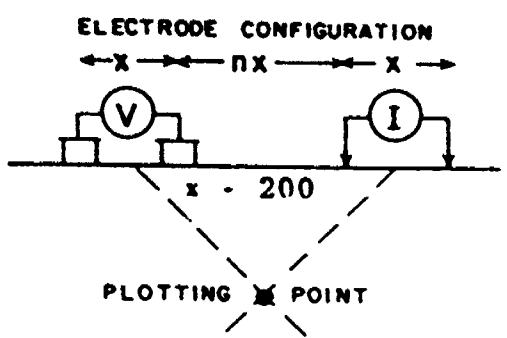

SURFACE PROJECTION
OF ANOMALOUS ZONES

DEFINITE

PROBABLE

POSSIBLE

NOVA BEAUCAGE MINES LIMITED
BILLOCKI PROPERTY, AYLMER TWP. - SUDBURY M.D. ONTARIO

Scale - One inch = 200 Feet

NOTE LOGARITHMIC CONTOUR INTERVAL

FREQUENCY 0.318 CPS

DATE SURVEYED MARCH 1966

APPROVED

DATE 3/22/66

LINE NO. - 8 E



ONTARIO
DEPARTMENT OF MINES
Mining Lands Branch

63.1799

PARLIAMENT BUILDINGS
TORONTO 2, ONTARIO

May 19, 1966.

Dear Sir:

Enclosed is a geophysical survey report submitted for assessment work credits on mining claims in Aylmer Township. The material was submitted by McPhar Geophysics Limited on behalf of J. J. Billoki.

Yours very truly,

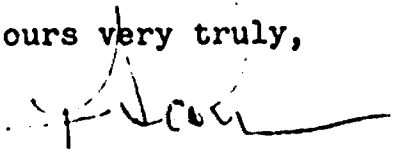

R. V. Scott,
Director.

FWM/csc
Encl.

Dr. Donovan,
Resident Geologist,
Box 1030,
SUDBURY, Ontario.



4115SW0006 0012 AYLNER

900

File 63.1799 (63.1799)

THE MINING ACT

Assessment Work Credits

Name: J. J. BILLOKI (J J BILLOKI)

Township or Area: AYLNER TWP: AYLNER TWP

Number of Assessment work days per claim

Geophysical (80) 80 Induced Polarisation Geological _____
INDUCED POLARIZATION

Mining Claims: 8 126216, 126218, 126220, 123191, 127176.
S 126216, 126218, 126220, 123191, 127176.

NOTE: Assessment work credits were not allowed for 8 127122 as it was not covered by this survey.

NOTE: ASSESSMENT WORK CREDITS WERE NOT ALLOWED FOR S 127122 AS IT WAS NOT COVERED BY THIS SURVEY.

WATWEB AND W.C.

Barry Option
~~Leased Exp (1959)~~

TELFER TWP.

Billoki, J.J.
Billoki, J.J.
(1966)
(1966)

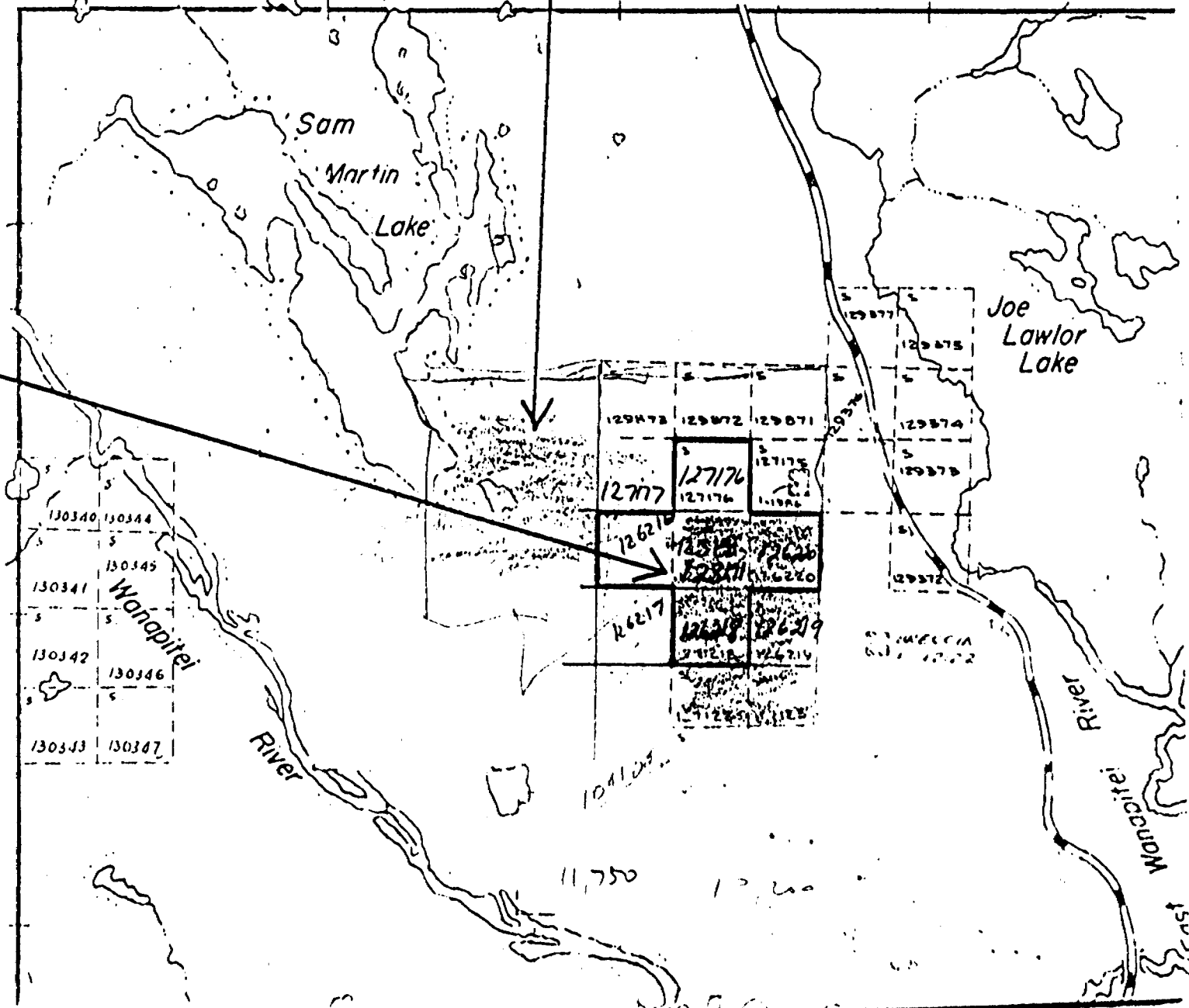

IN TWP.

SEE ACCOMPANYING
MAP(S) IDENTIFIED AS

AYLMER 0012, #1

LOCATED IN THE MAP
CHANNEL IN THE FOLLOWING
SEQUENCE (X)

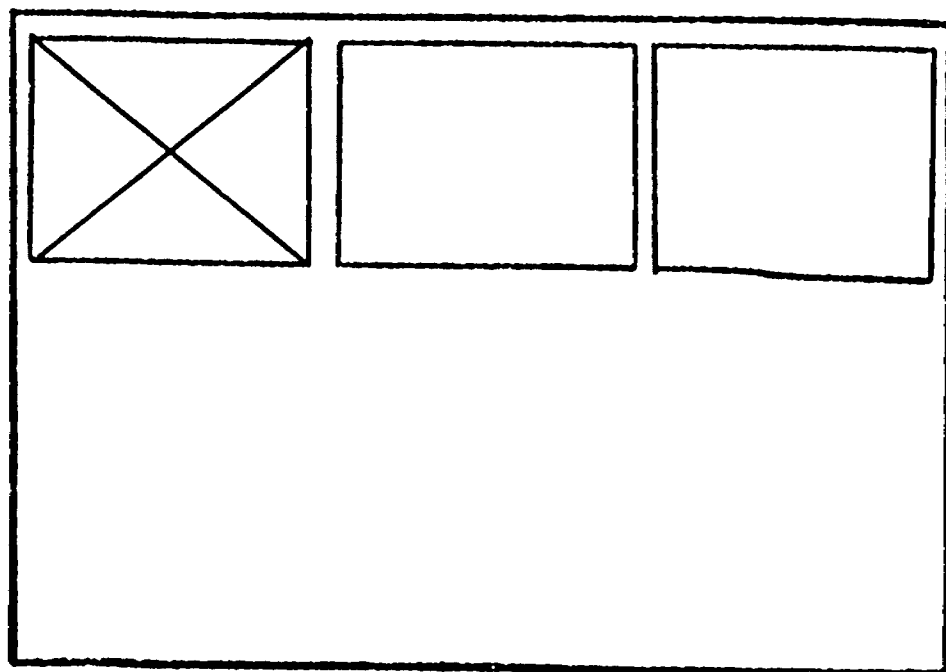

McPHAR GEOPHYSICS LIMITED

INDUCED POLARIZATION AND RESISTIVITY SURVEY

LOCATION MAP

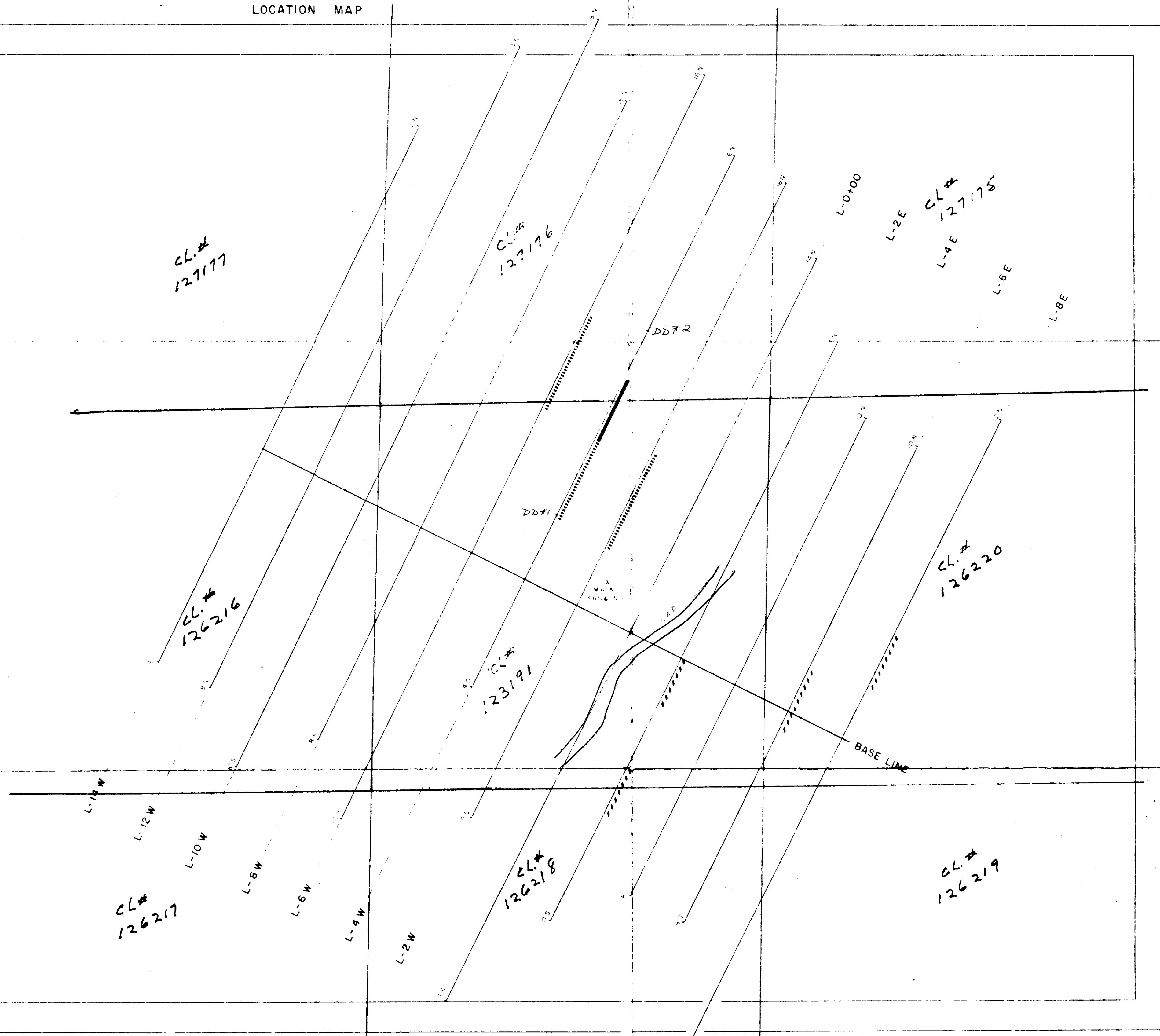
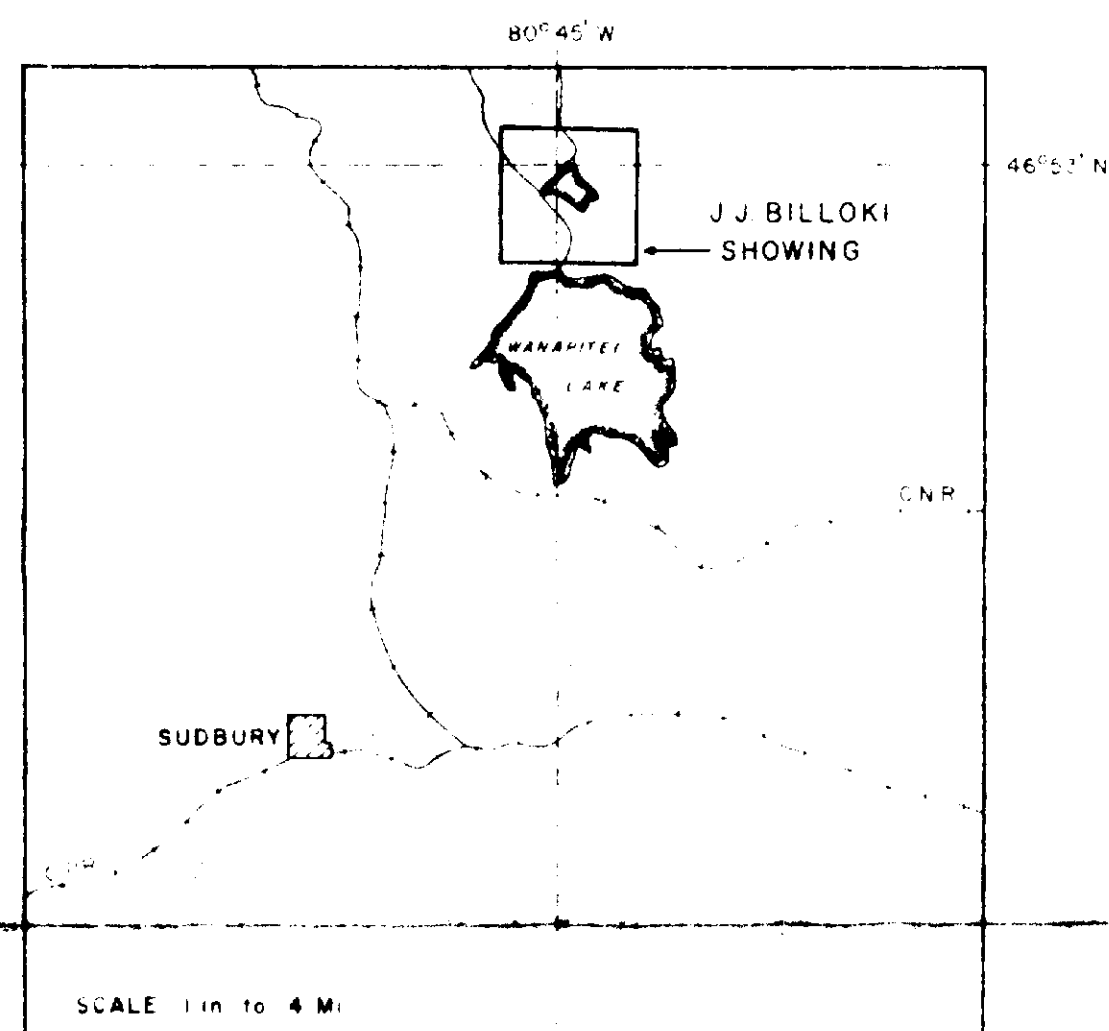

NOVA BEAUCAGE MINES LIMITED

BILLOKI PROPERTY, AYLMEY TWP. - SUDBURY M.D. - ONTARIO

SCALE

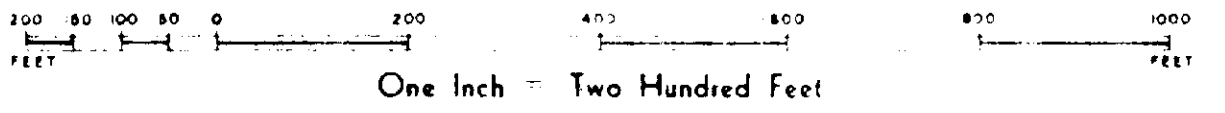

ANOMALOUS ZONE ———
 PROBABLE ANOMALOUS ZONE - - - - -
 POSSIBLE ANOMALOUS ZONE



DRAWN: G. G. G. G.
 DATE: 12/1/88
 APPROVED: [Signature]
 DATE: 12/1/88

AYLMER 0012, #1